



Oregon

Theodore R. Kulongoski, Governor

Water Resources Department

North Mall Office Building
725 Summer Street NE, Suite A
Salem, OR 97301-1266
503-986-0900
FAX 503-986-0904

September 8, 2008

ERIC G HANSEN #10067
TACOMA PUMP & DRILLING CO INC
30316 MOUNTAIN HWY
GRAHAM, WA 98338

FINAL ORDER

Dear Mr. Hansen:

The Special Standard request you submitted for owner: McKinstry Co. LLC, Start Card numbers 1004850 and 1004851 (Wells MKP1 and MKP2), is hereby approved for the following: You may drill these wells within 50 feet from a closed sewer line in the parking lot of this property. The wells shall be continuously cased and continuously sealed to a minimum depth of 40 feet bgs. The annular seals shall be deeper if required by Statute and Rule. These wells may not have split seals (See OAR 690-210-0030). All other construction requirements must be adhered to. Your Special Standard request form is enclosed. This Special Standard is in regards to the minimum well construction standards. Permits may be required from the Water Resources Department, or other agencies, to use these wells.

The Well Construction Standards serve to protect ground water resources. By approving and issuing this special construction standard the Oregon Water Resources Department is not representing that a well constructed in accordance with this condition will maintain structural integrity or that it meets engineering standards. The well constructor/or landowner is responsible for ensuring that a well is constructed in a manner that protects ground water resources as required under Oregon Administrative Rules 690-200 through 690-240.

If you have any questions concerning this letter, please contact me at (503) 986-0851, or by e-mail at Kristopher.R.Byrd@wrdd.state.or.us.

Sincerely,

Kristopher Byrd
Well Construction Program Coordinator
Well Construction and Compliance Section

enclosure

cc: Joel Jeffery, NW Region Well Inspector
File

This is a final order in other than contested case. This order is subject to judicial review under ORS 183.484. Any petition for judicial review must be filed within the 60 day time period specified by ORS 183.484(2). Pursuant to ORS 536.075 and OAR 137-004-0080 you may either petition for judicial review or petition the Director for reconsideration of this order. A petition for reconsideration may be granted or denied by the Director, and if no action is taken within 60 days following the date the petition was filed, the petition shall be deemed denied.



Oregon Water Resources Department
 725 Summer Street NE, Suite A
 Salem Oregon 97301-1266
 (503) 986-0900
 www.wrd.state.or.us

Special Standards Request Form

REQUEST FOR WRITTEN APPROVAL TO USE CONSTRUCTION METHODS NOT INCLUDED IN OREGON ADMINISTRATIVE RULES 690-200 THROUGH 690-240

Before the request can be considered, this form must be completed. Requests shall be submitted to the Well Construction Program Coordinator, Water Resources Department, 725 Summer Street NE, Suite A, Salem OR 97301-1266. Requests may also be considered by the appropriate Regional Manager.

Date of request: AUG 28, 08 Oral approval date (if applicable): KRIS BYRD TO ROGER SMITH/RG.

Bonded Well Constructor (name, license #, and mailing address): ERIC HANSEN #10067

(1) Location of Well: NE 1/4 SW 1/4 Tax lot 00311 / 00316 Section 19,
 Township 1 N, Range 3 E, MULTNOMAH County
 Address at well site:

16790 NE MASON ST. PORTLAND OR 97230

(2) Start Card Number(s)(for work to be done): 1004850 & 1004851

(3) Name and Address of Land Owner: MCKINSTY CO LLC

(4) Distance to the nearest septic tank, drainfield, closed sewage line (if water supply well)

LATERAL SEWER LINE WITHIN 50 FEET

(5) The unusual site conditions which necessitate this request:

CLOSED
CAN NOT MEET SETBACK FROM SEWER LINE

(6) The proposed construction methods that the bonded well constructor believes will be adequate for this well: (attach additional pages if needed)

INSTALL MINIMUM 30-40 FT SURFACE SEAL

- (7) Diagram showing the pertinent features of the proposed well design and construction:
(attach additional pages if needed)

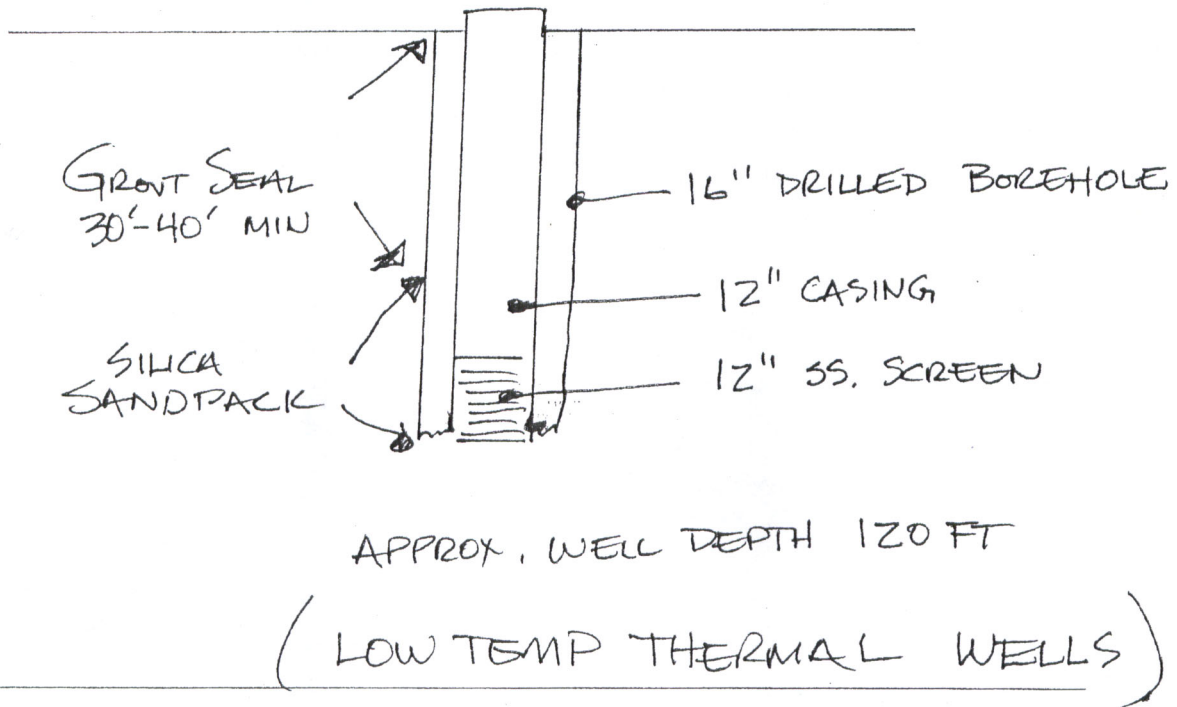

PLEASE NOTE:

- (1) The Well Construction Standards serve to protect ground water resources. By approving and issuing this special construction standard the Oregon Water Resources Department is not representing that a well constructed in accordance with this condition will maintain structural integrity or that it meets engineering standards. The well constructor/or landowner is responsible for ensuring that a well is constructed in a manner that protects ground water resources as required under Oregon Administrative Rules 690-200 through 690-240.
- (2) If it should be determined at some future date that the well, due to its construction, is allowing ground water contamination, waste or loss of artesian pressure, the undersigned shall return to the site and rectify the problem.
- (3) If oral approval was granted, a written request must be submitted to the Department either within three (3) working days of the date of oral approval or prior to the completion of the associated well work. Failure to submit a written request as described above may void prior oral approval.

I have read and understand the above information. I further attest that the information provided is accurate to the best of my knowledge.

Bonded Constructor Signature: _____

[Handwritten Signature] SEPT 8, 2008

