



# Oregon

Theodore R. Kulongoski, Governor

**Water Resources Department**

North Mall Office Building  
725 Summer Street NE, Suite A  
Salem, OR 97301-1266  
503-986-0900  
FAX 503-986-0904

March 3, 2010

FLOYD G SIPPEL #1273  
SIPPEL WELL DRILLING  
7195 LAWRIDGE ST NE  
KEIZER OR 97303

## FINAL ORDER

Dear Floyd:

The Special Standard request you submitted for owner: City of Keizer, Start Card number 205269, is hereby approved for the following: After verifying that the well is clean to the natural bottom, you may abandon this water supply well as described on your Special Standard Request Form (enclosed). All other well abandonment standards must be adhered to. A copy of your Special Standard Request Form is enclosed.

The Well Construction Standards serve to protect ground water resources. By approving and issuing this special construction standard the Oregon Water Resources Department is not representing that a well constructed in accordance with this condition will maintain structural integrity or that it meets engineering standards. The well constructor/or landowner is responsible for ensuring that a well is constructed in a manner that protects ground water resources as required under Oregon Administrative Rules 690-200 through 690-240.

If you have any questions concerning this letter, please contact me at (503) 986-0851, or by e-mail at [Kristopher.R.Byrd@ wrd.state.or.us](mailto:Kristopher.R.Byrd@ wrd.state.or.us).

Sincerely,

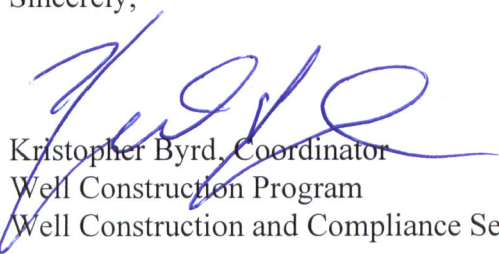

Kristopher Byrd, Coordinator  
Well Construction Program  
Well Construction and Compliance Section

enclosure

cc: Jon Unger, NW Region Well Inspector  
File

**This is a final order in other than contested case. This order is subject to judicial review under ORS 183.484. Any petition for judicial review must be filed within the 60 day time period specified by ORS 183.484(2). Pursuant to ORS 536.075 and OAR 137-004-0080 you may either petition for judicial review or petition the Director for reconsideration of this order. A petition for reconsideration may be granted or denied by the Director, and if no action is taken within 60 days following the date the petition was filed, the petition shall be deemed denied.**





Oregon Water Resources Department
725 Summer Street NE, Suite A
Salem Oregon 97301-1266
(503) 986-0900
www.wrd.state.or.us

Special Standards
Request Form

REQUEST FOR WRITTEN APPROVAL TO USE CONSTRUCTION METHODS NOT INCLUDED IN OREGON ADMINISTRATIVE RULES 690-200 THROUGH 690-240

Before the request can be considered, this form must be completed. Requests shall be submitted to the Well Construction Program Coordinator, Water Resources Department, 725 Summer Street NE, Suite A, Salem OR 97301-1266. Requests may also be considered by the appropriate Regional Manager.

Date of request: 3/3/10 Oral approval date (if applicable):

Bonded Well Constructor (name, license #, and mailing address): Sippel Well Drilling Inc
Lic # 1273 7195 Lawnridge St NE Keizer OR

(1) Location of Well: SW 1/4 NE 1/4 Tax lot 4500 Section 2, Township 7-S N, Range 3-WW, Marion County
Address at well site: 1150 Brandon St NE Keizer OR

(2) Start Card Number(s)(for work to be done): 205269

(3) Name and Address of Land Owner: City of Keizer
PO Box 21000 Keizer OR 97307

(4) Distance to the nearest septic tank, drainfield, closed sewage line (if water supply well)
City Sewer ?

(5) The unusual site conditions which necessitate this request: Well Located in-side building Screen set in hole I feel a better Abandonment would be, leave Screen + Tail pipe unperforated so as not to move screen

(6) The proposed construction methods that the bonded well constructor believes will be adequate for this well: (attach additional pages if needed)
Perforate all 12 in casing that is not perforated leave 8in Screen + Tail pipe as is and cement hole

- (7) Diagram showing the pertinent features of the proposed well design and construction: (attach additional pages if needed)

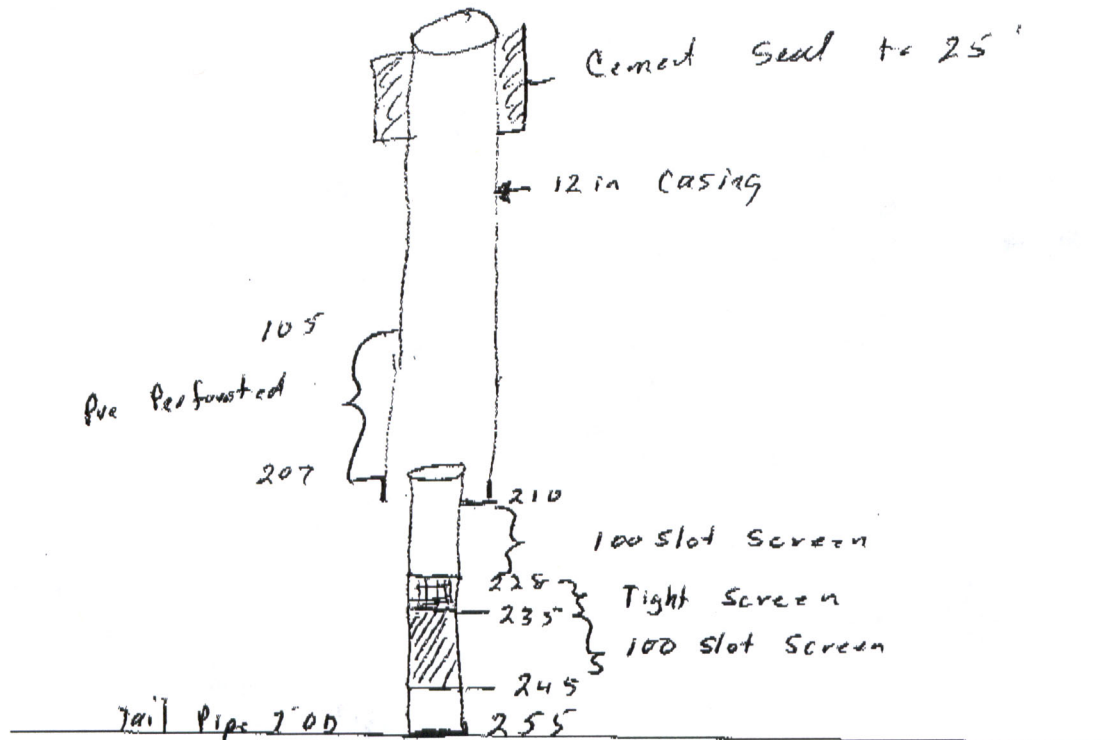

PLEASE NOTE:

- (1) The Well Construction Standards serve to protect ground water resources. By approving and issuing this special construction standard the Oregon Water Resources Department is not representing that a well constructed in accordance with this condition will maintain structural integrity or that it meets engineering standards. The well constructor/or landowner is responsible for ensuring that a well is constructed in a manner that protects ground water resources as required under Oregon Administrative Rules 690-200 through 690-240.
- (2) If it should be determined at some future date that the well, due to its construction, is allowing ground water contamination, waste or loss of artesian pressure, the undersigned shall return to the site and rectify the problem.
- (3) If oral approval was granted, a written request must be submitted to the Department either within three (3) working days of the date of oral approval or prior to the completion of the associated well work. Failure to submit a written request as described above may void prior oral approval.

I have read and understand the above information. I further attest that the information provided is accurate to the best of my knowledge.

Bonded Constructor Signature: *Floyd App*