



Oregon

Theodore R. Kulongoski, Governor

ev 7/30/03

Water Resources Department

Commerce Building
158 12th Street NE
Salem, OR 97301-4172
503-378-3739
FAX 503-378-8130

July 15, 2003

WESTERBERG DRILLING
STEVEN N STADELI # 688
36728 S KROPF RD
MOLALLA OR 97038

FINAL ORDER

Dear Steve:

The special standard request you submitted for owner: Moana Nursery, start card number 155751, is approved for the following: removing the drilling machine from the well site prior to completion of the well. The special standard is in effect from July 14, 2003, until July 17, 2003. See Oregon Administrative Rule (OAR) 690-210-0390. Your special standard request form is enclosed.

The Well Construction Standards serve to protect ground water resources. By approving and issuing this special construction standard the Oregon Water Resources Department is not representing that a well constructed in accordance with this condition will maintain structural integrity or that it meets engineering standards. The well constructor/or landowner is responsible for ensuring that a well is constructed in a manner that protects ground water resources as required under Oregon Administrative Rules 90-200 through 690-240.

If you have any questions concerning this letter, please contact me at (503) 378-8455 ext. 283, or by e-mail at tracy.l.eichenlaub@wrdd.state.or.us.

Sincerely,

Tracy Eichenlaub
Ms. Tracy Eichenlaub
Well Construction Specialist
Enforcement Section

enclosure

cc: Kris Byrd, NW Region Well Inspector

This is a final order in other than a contested case. This order is subject to judicial review under ORS 183.484. Any petition for judicial review of the order must be filed within the 60 day time period specified by ORS 183.484(2). Pursuant to ORS 536.075 and OAR 137.004-0080 and OAR 690-01-0005 you may either petition for judicial review or petition the Director for reconsideration of this order.

Oregon Water Resources Department

REQUEST FOR WRITTEN APPROVAL TO USE CONSTRUCTION METHODS NOT INCLUDED IN OREGON ADMINISTRATIVE RULES 690-200 THROUGH 690-240

Before the request can be considered, this form must be completed. Requests shall be submitted to the Well Construction Specialist, Water Resources Department, 158 12th Street NE, Salem OR 97301. Requests may also be considered by the appropriate Regional Manager.

Date of request: 7-15-03 Oral approval date (if applicable): 7-14-03
Bonded Well Constructor (name, license #, and mailing address): Westerberg Drilling, Inc.
36728 S. Kropf Rd.
Molalla, OR 97038
829-2526
Steven N. Stadelic Lic. # 1688

(1) Location of Well: NE 1/4 SE 1/4 of Section 6,
Township 4S N/S, Range 1E E/W, Clackamas County
Address at well site: S. Anderson Rd. Canby OR 97013

(2) Start Card Number(s)(for work to be done): 155751

(3) Name and Address of Land Owner: Moana Nursery
24395 S. Barlow Rd. Canby OR 97013

(4) Distance to the nearest septic tank, drainfield, closed sewage line (if water supply well)
100'+

(5) The unusual site conditions which necessitate this request: Need to remove
air rotary drilling rig on 7-14-03. Cable tool rig
will be mobilized & set up on well on 7-17-03.

(6) The proposed construction methods that the bonded well constructor believes will be adequate for this well: (attach additional pages if needed)
12" temporary surface casing installed to 125' approx.
8" casing installed to 360'. Steel plate welded
between 8" & 12" casings. Steel plate welded over
8" casing (lid).

RECEIVED

JUL 15 2003

WATER RESOURCES DEPT.
SALEM, OREGON

W-DR

- (7) Diagram showing the pertinent features of the proposed well design and construction:
(attach additional pages if needed)

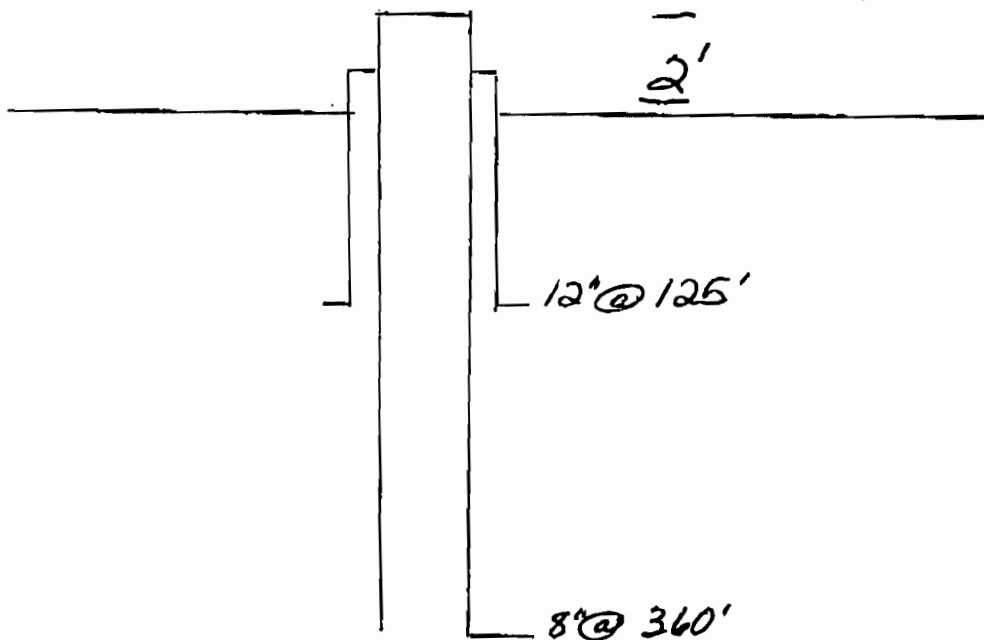

PLEASE NOTE:

- (1) The Well Construction Standards serve to protect ground water resources. By approving and issuing this special construction standard the Oregon Water Resources Department is not representing that a well constructed in accordance with this condition will maintain structural integrity or that it meets engineering standards. The well constructor/or landowner is responsible for ensuring that a well is constructed in a manner that protects ground water resources as required under Oregon Administrative Rules 90-200 through 690-240.
- (2) If it should be determined at some future date that the well, due to its construction, is allowing ground water contamination, waste or loss of artesian pressure, the undersigned shall return to the site and rectify the problem.
- (3) If oral approval was granted, a written request must be submitted to the Department either within three (3) working days of the date of oral approval or prior to the completion of the associated well work. Failure to submit a written request as described above may void prior oral approval.

I have read and understand the above information. I further attest that the information provided is accurate to the best of my knowledge.

Bonded Constructor Signature: Steven N. Stadelic Lic. # 688
CMAA

revised 07/07/2003

FAX COVER SHEET

Westerberg Drilling Inc.
 36728 S. Kropf Rd.
 Molalla, OR 97038
 Phone (503) 829-2526
 Fax (503) 829-7514

SEND TO	
Attention <i>Tracy Eichenlaub</i>	From <i>Steve Stadel</i>
Company Name <i>WRD</i>	Date <i>7-15-03</i>
Office location	Office location
Fax number <i>503-378-8130</i>	Phone number

- Urgent
 Reply ASAP
 Please comment
 Please review
 For your information

Total pages, including cover: 3

COMMENTS

request
 RE: Special Standards for well on
 Anderson Rd. in Corby

RECEIVED
 JUL 15 2003
 WATER RESOURCES DEPT
 SALEM, OREGON