

# FINAL PROOF SURVEY MAP

IN THE NAME OF DANIEL M. TILSON

SECTION 16, T26S, R3W, W.M.

APPLICATION 70131

PERMIT 50984



1 INCH = 1320 FEET

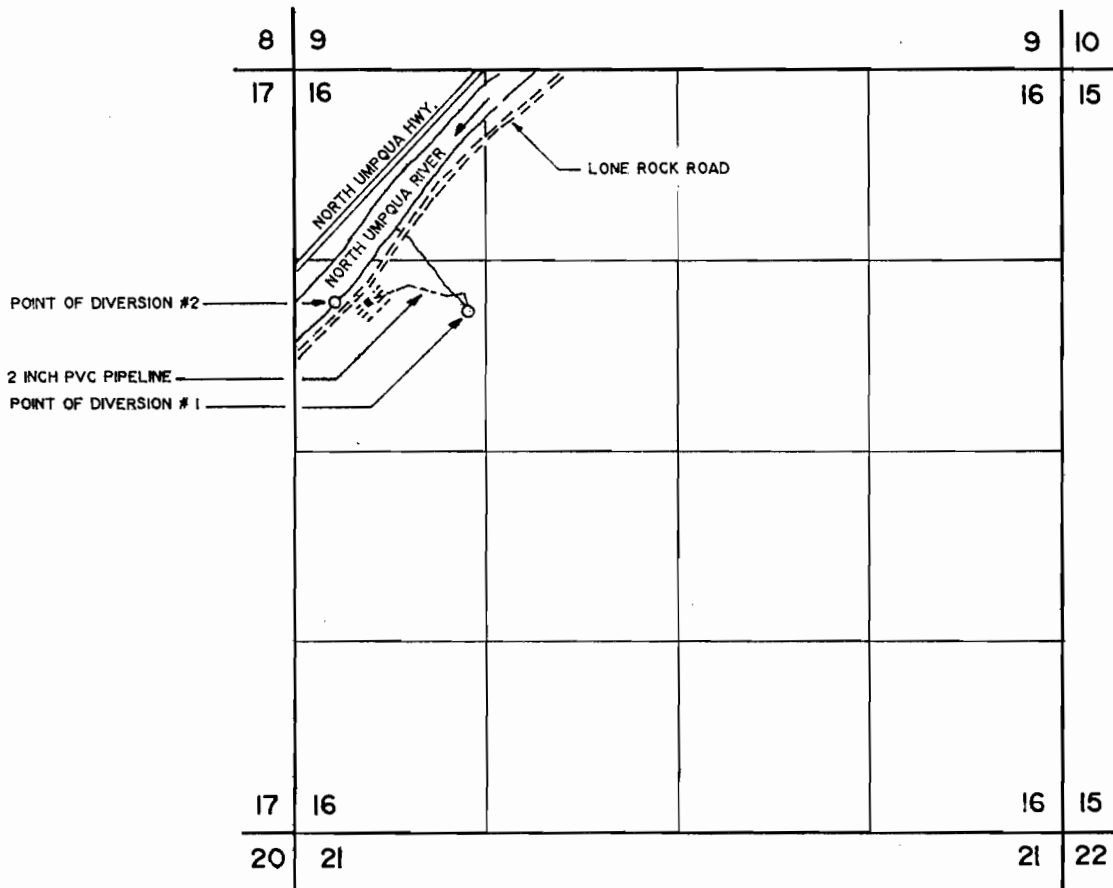

POINT OF DIVERSION #1 IS LOCATED 1670 FEET SOUTH AND 1210 FEET EAST FROM THE NORTHWEST CORNER OF SECTION 16, BEING WITHIN THE SW 1/4 OF THE NW 1/4 OF SECTION 16, TOWNSHIP 26 SOUTH, RANGE 3 WEST, W. M.

POINT OF DIVERSION #2 IS LOCATED 1600 FEET SOUTH AND 260 FEET EAST FROM THE NORTHWEST CORNER OF SECTION 16, BEING WITHIN THE SW 1/4 OF THE NW 1/4 OF SECTION 16, TOWNSHIP 26 SOUTH, RANGE 3 WEST, W. M.

THE PURPOSE OF THIS MAP IS TO IDENTIFY THE LOCATION OF THE WATER RIGHT. IT IS NOT INTENDED TO PROVIDE INFORMATION RELATIVE TO THE LOCATION OF PROPERTY OWNERSHIP BOUNDARY LINES.

