

RECEIVED

OCT - 9 1992

**FINAL PROOF MAP:
 CHANGE IN POINT OF APPROPRIATION
 LLOYD MILES
 LOCATED IN SECTION 2,
 TOWNSHIP 27 SOUTH, RANGE 15 EAST,
 WILLAMETTE MERIDIAN, IN
 LAKE COUNTY, OREGON**

WATER RESOURCES DIVISION
 OREGON DEPARTMENT OF GEOLOGY

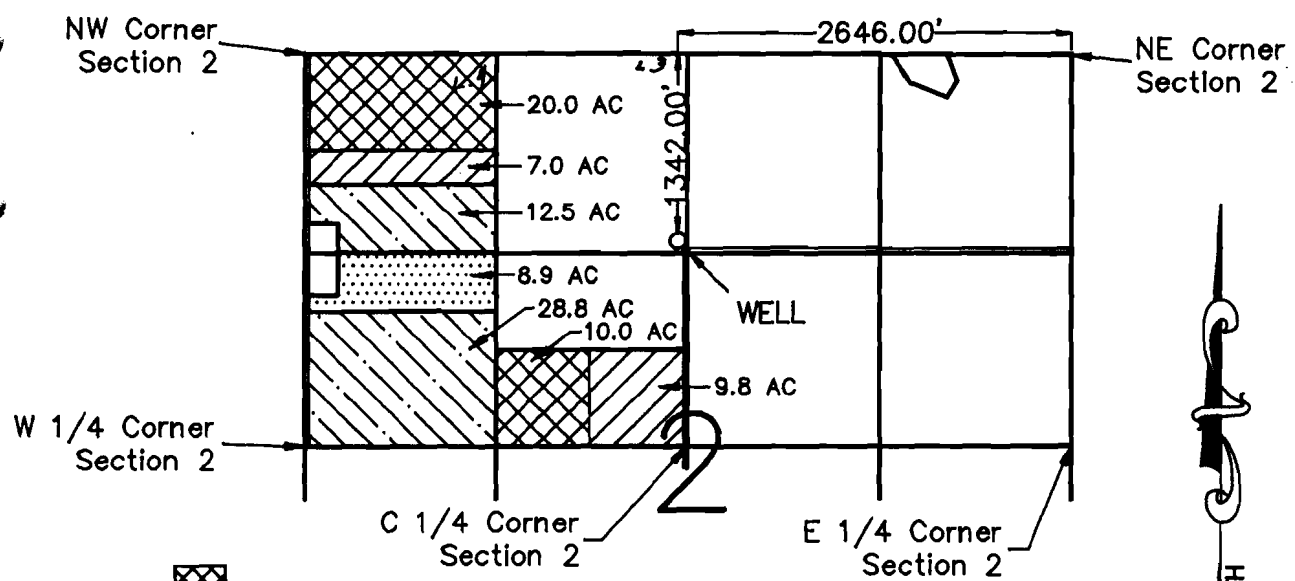

- = C27430 PRIMARY
- = C31369 PRIMARY
- = C27427 PRIMARY
- = C27427 SECONDARY *supplemental*

31369

T-6248 TOTAL IRRIGATED AREA = 97.0 ACRES



SCALE: 1"=1320'

I, Michael W. Tye, Certified Water Right Examiner in the State of Oregon, hereby certify that this final proof map was prepared under my direct supervision.

The preparation of this map is for the purpose of identifying the location of the water right only and has no intent to provide dimensions or locations of property ownership lines.

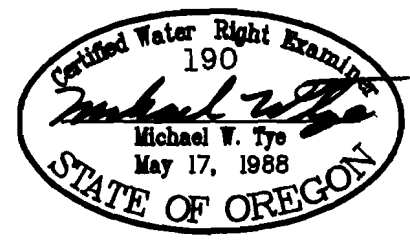

SCALE	1"=1320'	DATE	9-17-92	SURVEY BY	MT&BM	DRAWN BY	P.A.R.	ORDER NO.	3101A
-------	----------	------	---------	-----------	-------	----------	--------	-----------	-------

SUN COUNTRY ENGINEERING & SURVEYING, INC.
 61555 PARRELL ROAD BEND, OREGON 97702 PHONE 382-8882