

T28S, R5W, WM

DOUGLAS COUNTY
SCALE 1" = 1320'

RECEIVED

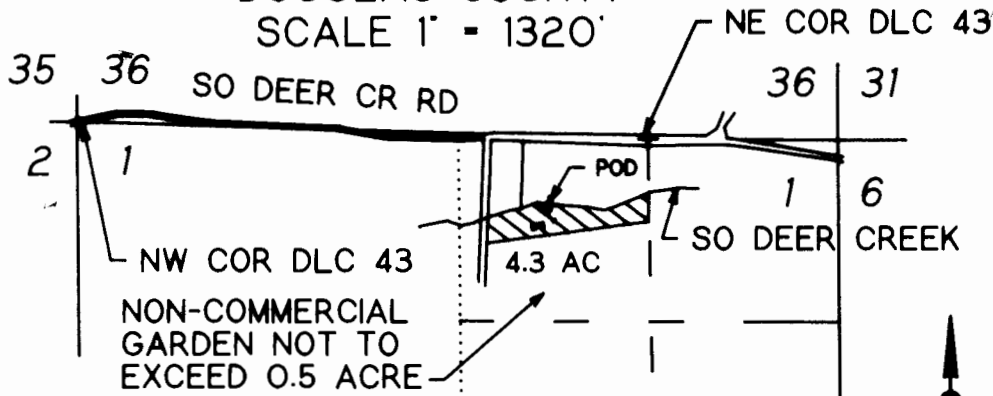

DETAIL
SCALE 1" = 400'

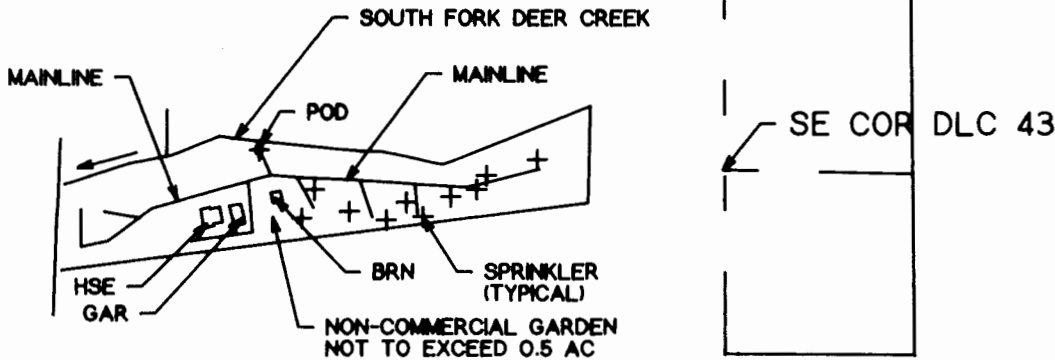

POD IS 450 FT S AND 2010 FT W FROM NE COR SEC 1

FINAL PROOF SURVEY

UNDER

Application No. 69215 Permit No. 50976

IN NAME OF

DAVID G. TERRY AND LANI KIMOTO TERRY

Surveyed Sept 14, 1994 by M.E. Farr

THIS IS A LOCATION MAP FOR A FINAL PROOF SURVEY BY DAVID G. AND LANI KIMOTO TERRY. THIS MAP IS FOR THE PURPOSE OF IDENTIFYING THE LOCATION OF THE WATER RIGHT ONLY AND IS NOT INTENDED TO PROVIDE LEGAL DIMENSIONS OR LOCATIONS OF PROPERTY OWNERSHIP LINES.

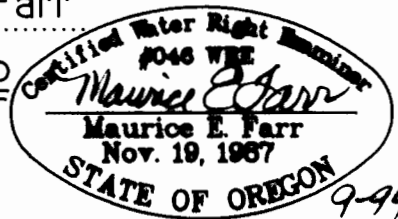

EXPRES 12-31-95