

FINAL PROOF MAP

TO TRANSFER RIGHTS AND
CHANGE POINT OF APPROPRIATION
FOR T-9033
DORIS H. KITTREDGE

TOWNSHIP 25 SOUTH, RANGE 15 EAST, SECTION 31, W.M.
TAX LOT: 101

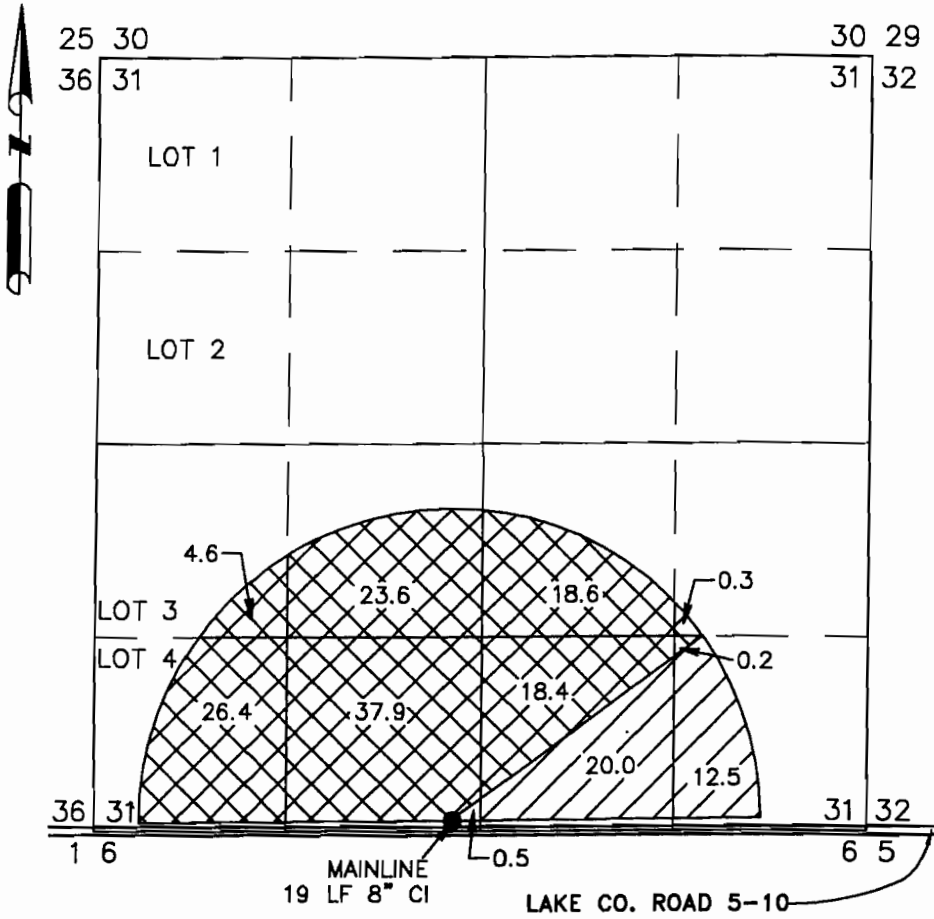
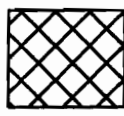

 130.0 ACRES FROM G-2314 (CERT.# 55397) TO BE TRANSFERRED, AS SHOWN

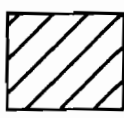
 33.0 ACRES FROM G-5007 (CERT.# 44493) TO BE TRANSFERRED, AS SHOWN

- NEW POINT OF APPROPRIATION
NEWLY CONSTRUCTED WELL FROM PERMIT: G-2314
63 FEET NORTH AND 2432 FEET EAST FROM THE SW CORNER SECTION 31

NEWLY INSTALLED METER IS APPROXIMATELY 10 FEET WEST OF WELL

RECEIVED

JUN 06 2008

WATER RESOURCES DEPT
SALEM, OREGON

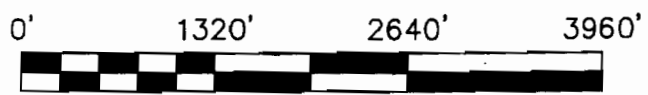

THIS MAP IS FOR THE PURPOSE OF LOCATING A WATER RIGHT ONLY AND HAS NO INTENT TO PROVIDE LEGAL DIMENSIONS OR THE LOCATION OF PROPERTY LINES

<p>PREPARED FOR:</p> <p>SCOTT KITTREDGE P.O. BOX 25 FORT ROCK, OR 97735</p>	<p>PREPARED BY:</p>  <p>ALL POINTS ENGINEERING AND SURVEYING, INC. P.O. BOX 767 (CRR) TERREBONNE, OR 97760 (541) 548-5833 www.APEandS.com</p>
---	--