

RECEIVED

MAR 12 1998

WATER RESOURCES DEPT.  
M. G. N.

SECTION 29, TOWNSHIP 20 SOUTH, RANGE 03 WEST, W. 6. N.



SCALE: 1" = 400'

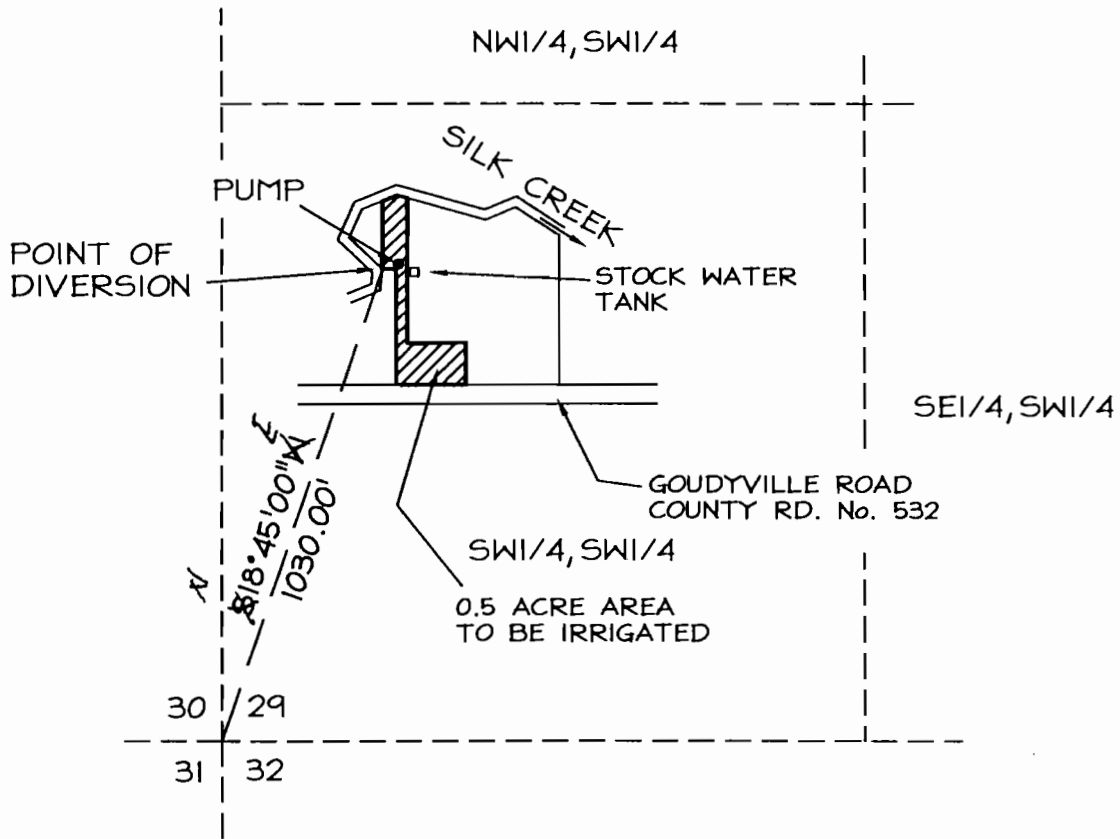

FINAL PROOF SURVEY

UNDER

APPL. No. 73456 PER No. 51556

FEBRUARY 6, 1998

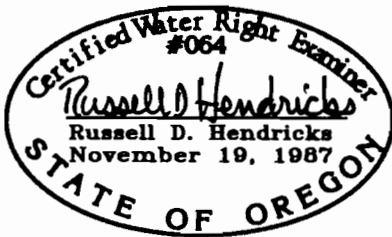

THIS MAP IS FOR THE PURPOSE OF IDENTIFYING THE WATER RIGHT ONLY AND IS NOT TO PROVIDE LEGAL DIMENSIONS OR LOCATIONS OF PROPERTY OWNERSHIP LINES.