

FINAL PROOF SURVEY  
FOR T-6697  
T2N & 3N R26E WM

RECEIVED  
MAR 9 1 2011  
WATER RESOURCES DEPT  
SALEM, OREGON

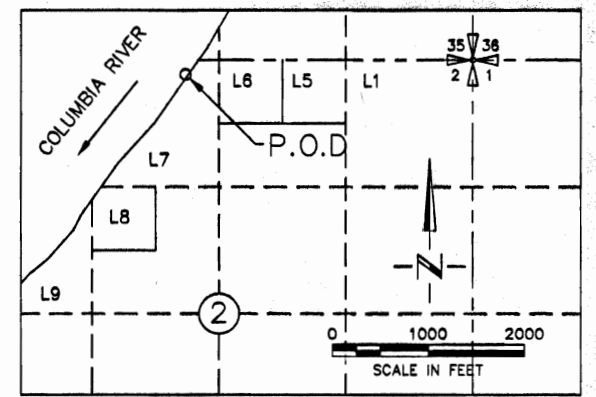

P.O.D. LOCATED 150' SOUTH AND 2990' WEST FROM THE NE CORNER OF SECTION 2, T4N, R25E WM

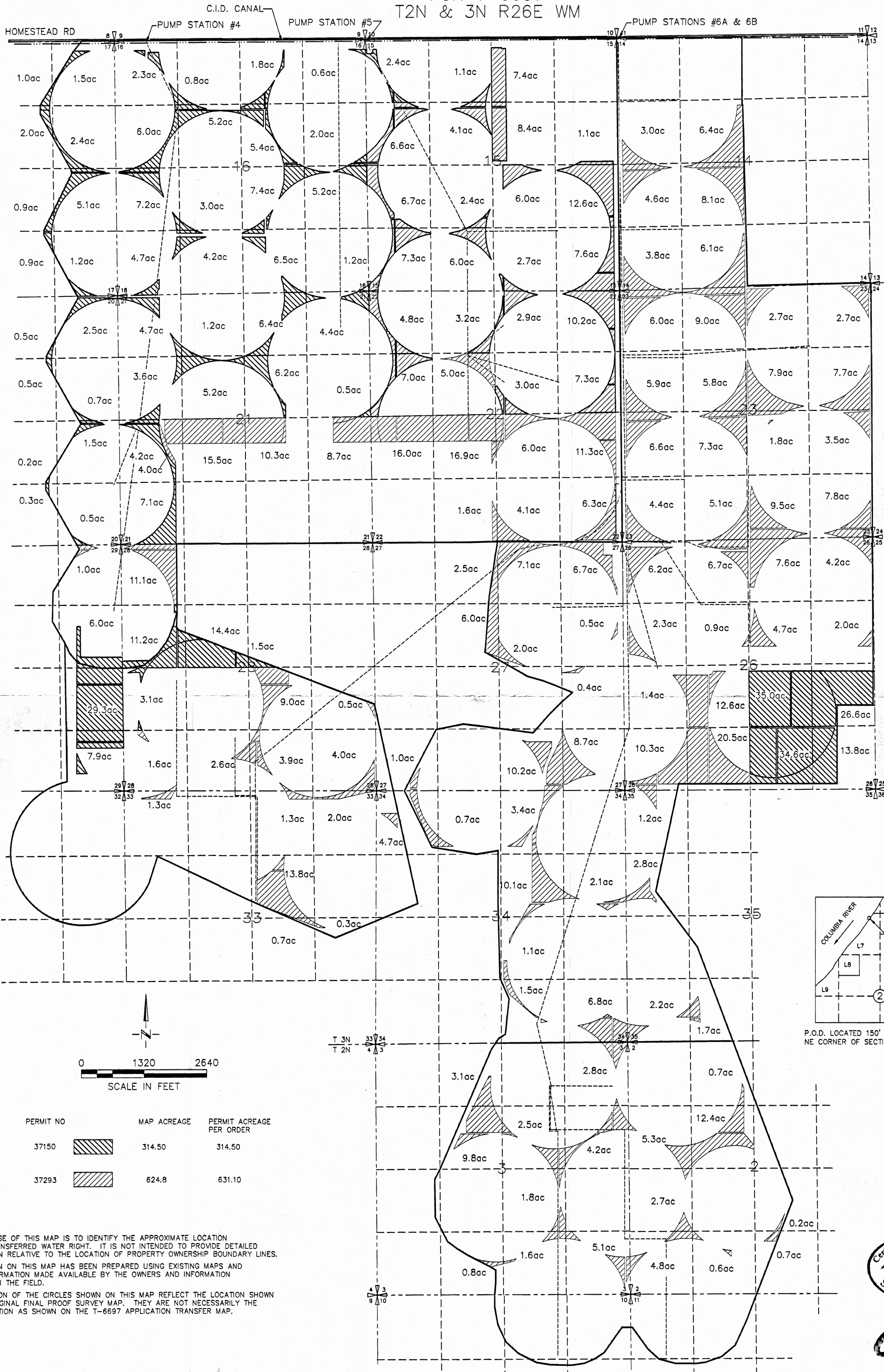
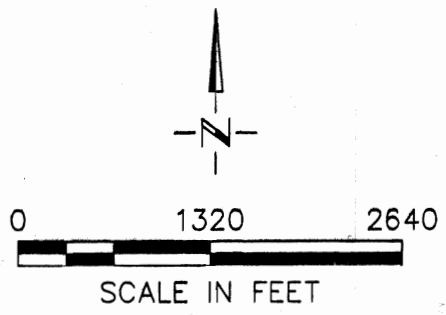

PERMIT NO	MAP ACREAGE	PERMIT ACREAGE PER ORDER
37150	314.50	314.50
37293	624.8	631.10

NOTE:  
THE PURPOSE OF THIS MAP IS TO IDENTIFY THE APPROXIMATE LOCATION OF THE TRANSFERRED WATER RIGHT. IT IS NOT INTENDED TO PROVIDE DETAILED INFORMATION RELATIVE TO THE LOCATION OF PROPERTY OWNERSHIP BOUNDARY LINES. INFORMATION ON THIS MAP HAS BEEN PREPARED USING EXISTING MAPS AND OTHER INFORMATION MADE AVAILABLE BY THE OWNERS AND INFORMATION OBTAINED IN THE FIELD.  
THE LOCATION OF THE CIRCLES SHOWN ON THIS MAP REFLECT THE LOCATION SHOWN ON THE ORIGINAL FINAL PROOF SURVEY MAP. THEY ARE NOT NECESSARILY THE SAME LOCATION AS SHOWN ON THE T-6697 APPLICATION TRANSFER MAP.

Certified Water Right Examiner  
#333 WRE  
*Dale G. VanSchoeck*  
Dale G. VanSchoeck  
May 19, 1992  
3/26/11  
STATE OF OREGON  
Renewed 6/30/12

0003