

# FINAL PROOF TRANSFER MAP FOR T-9159 T3N, R27E WM, MORROW COUNTY DON KEY

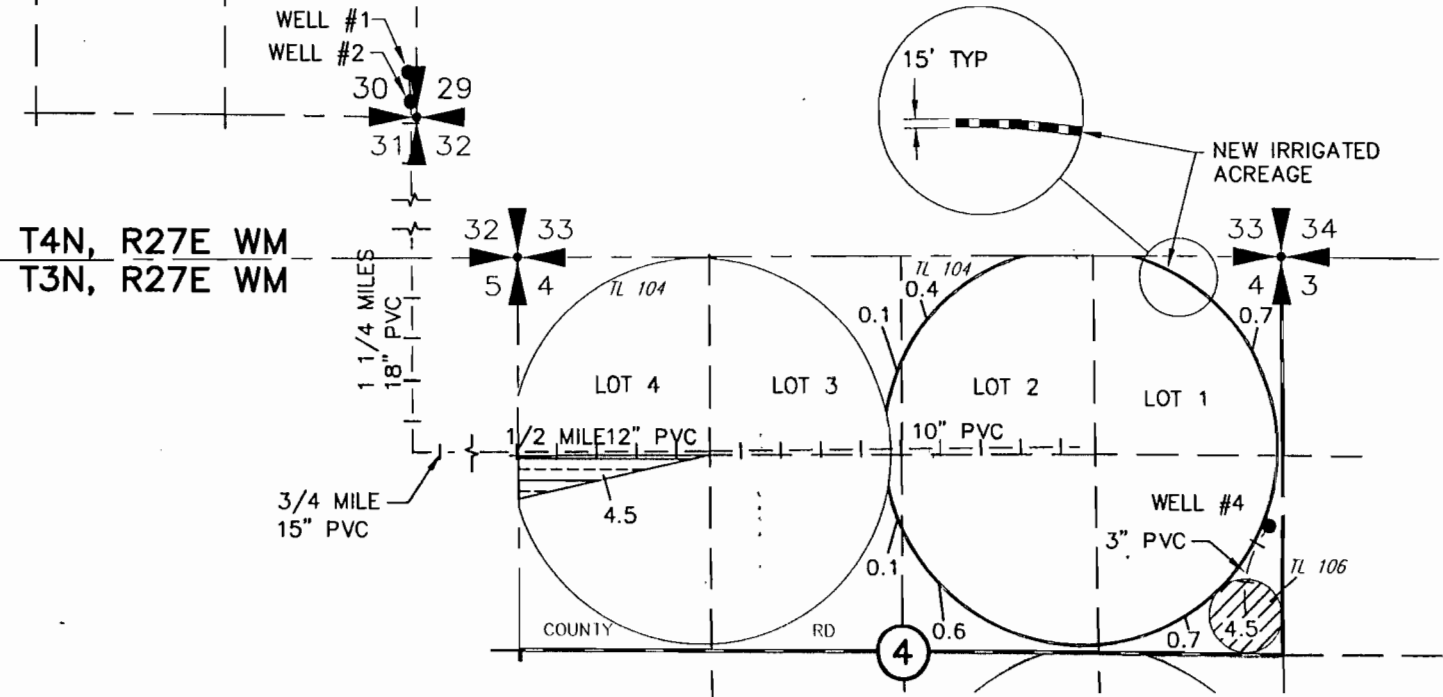

**PRIMARY PERMIT G-4878  
SUPPLEMENTAL PERMIT G-10836**

**PRIMARY PERMIT G-2823  
SUPPLEMENTAL PERMIT G-4878  
PERMIT G-10836**

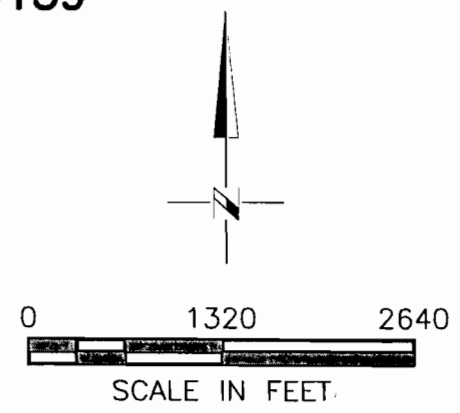
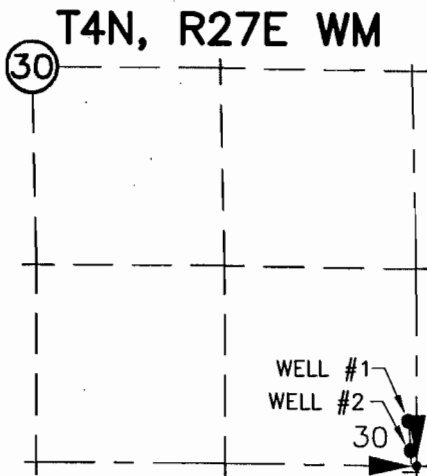
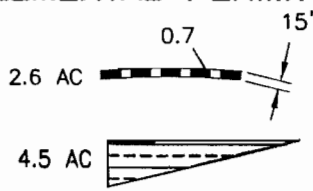

POINTS OF APPROPRIATION

WELL #1 LOCATED  
290' NORTH AND 50' WEST FROM THE  
SE CORNER OF SEC 30, T4N, R27E WM  
FLOW METER LOCATED AT WELL SITE

WELL #2 LOCATED  
100' NORTH AND 40' WEST FROM THE  
SE CORNER OF SEC 30, T4N, R27E WM  
FLOW METER LOCATED AT WELL SITE

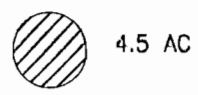

POINT OF APPROPRIATION

WELL #4 LOCATED  
790' NORTH AND 40' WEST FROM THE  
E 1/4 CORNER SEC 4, T3N, R27E WM  
FLOW METER IS LOCATED AT CENTER  
PIVOT

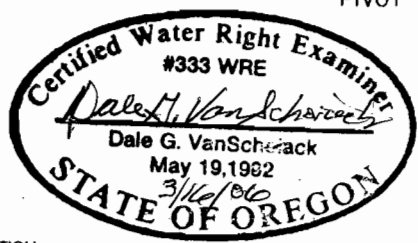

**RECEIVED**  
**MAR 22 2006**  
WATER RESOURCES DEPT  
SALEM, OREGON

NOTE:  
THE PURPOSE OF THIS MAP IS TO IDENTIFY THE APPROXIMATE LOCATION  
OF THE WATER RIGHT. IT IS NOT INTENDED TO PROVIDE INFORMATION  
RELATIVE TO THE LOCATION OF PROPERTY OWNERSHIP BOUNDARY LINES.

DRAWING: H:\CAD\AG\3522\316\35220316T.dwg  
PRINTED BY: Roger Willard on 03/16/06 10:15 AM