

FINAL PROOF MAP

TO TRANSFER RIGHTS AND
CHANGE POINT OF APPROPRIATION
FOR T-9814

GOLDEN RULES FARMS, INC.



TOWNSHIP 26 SOUTH, RANGE 17 EAST, SECTION 34, W.M.
TAX LOTS: 100, 200, 300, 400, AND 3700 LAKE COUNTY, OREGON

RECEIVED

MAY 13 2008

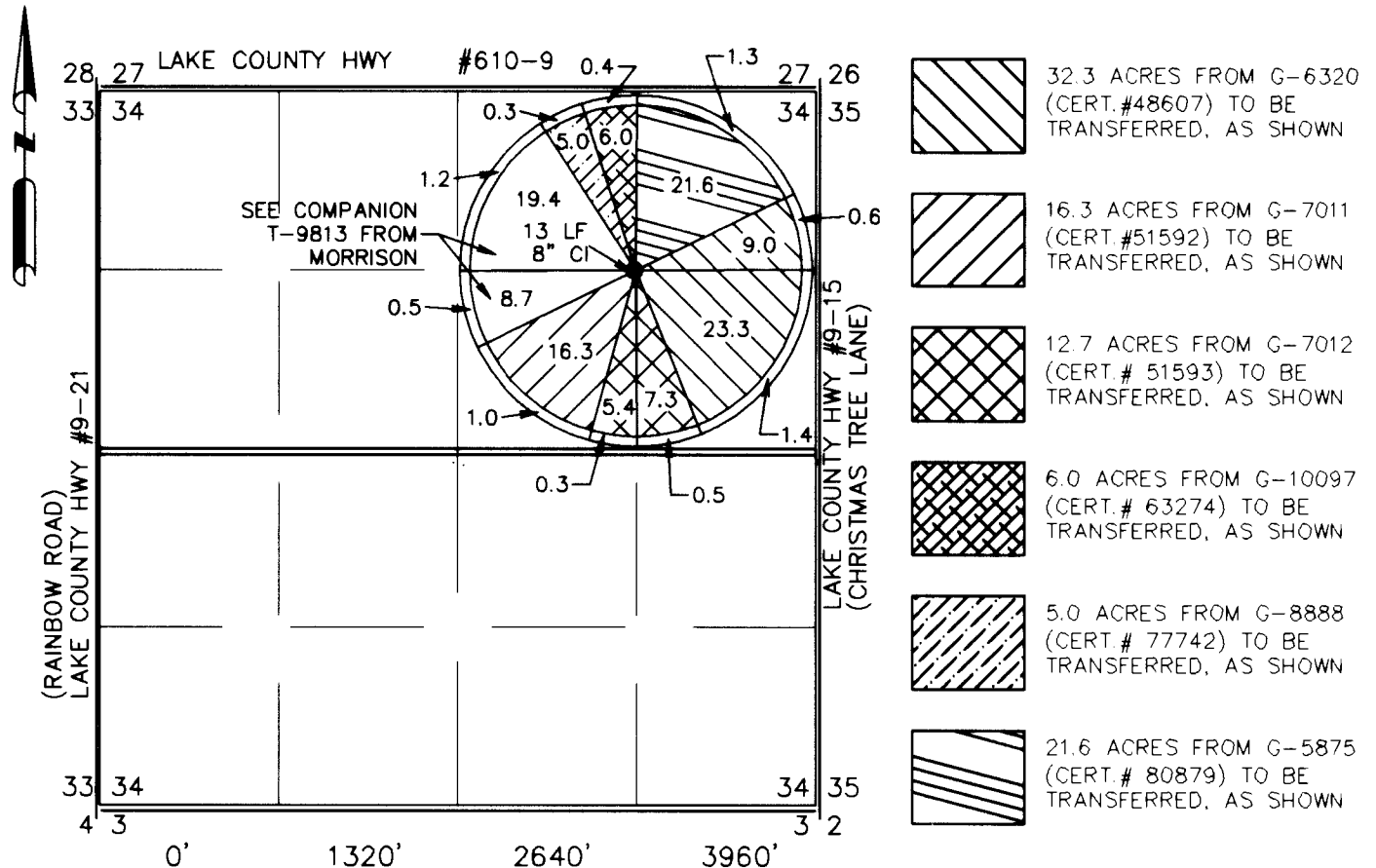
WATER RESOURCES DEPT
SALEM, OREGON

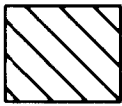
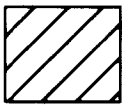
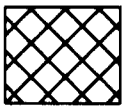
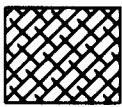
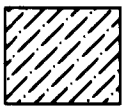

-  32.3 ACRES FROM G-6320 (CERT.#48607) TO BE TRANSFERRED, AS SHOWN
-  16.3 ACRES FROM G-7011 (CERT.#51592) TO BE TRANSFERRED, AS SHOWN
-  12.7 ACRES FROM G-7012 (CERT.# 51593) TO BE TRANSFERRED, AS SHOWN
-  6.0 ACRES FROM G-10097 (CERT.# 63274) TO BE TRANSFERRED, AS SHOWN
-  5.0 ACRES FROM G-8888 (CERT.# 77742) TO BE TRANSFERRED, AS SHOWN
-  21.6 ACRES FROM G-5875 (CERT.# 80879) TO BE TRANSFERRED, AS SHOWN

● PROPOSED POINT OF APPROPRIATION

NEW WELL (LAKE 51690)
PERMITS: G-5875, G-6320, G-7011,
G-7012, G-8888 & G-10097
1323' SOUTH 1340' WEST FROM THE NE
CORNER SECTION 34

P28
CENTER PIVOT IS LOCATED 2' NORTH 12'
WEST FROM WELL

METER IS LOCATED ON PIPE 4 FT. EAST
OF P28



Certified Water Right Examiner
#51324 WRE
Scott D. Montgomery 4/17/08
Scott D. Montgomery
May 21, 2001
STATE OF OREGON

RECEIVED

MAY 27 2008

WATER RESOURCES DEPT
SALEM, OREGON

RENEWAL 12/31/08

THIS MAP IS FOR THE PURPOSE OF LOCATING A WATER RIGHT ONLY AND HAS NO INTENT TO PROVIDE LEGAL DIMENSIONS OR THE LOCATION OF PROPERTY LINES

<p>PREPARED FOR:</p> <p>TIM PUCKETT P.O. BOX 255 CHRISTMAS VALLEY, OR 97641</p>	<p>PREPARED BY:</p>  <p>ALL POINTS ENGINEERING AND SURVEYING, INC. P.O. BOX 767 (CRR) TERREBONNE, OR 97760 (541) 548-5833 www.APEandS.com</p>
---	--