

MAP TO ACCOMPANY APPLICATION
TO CHANGE PLACE OF USE
AND POINT OF APPROPRIATION
FOR
TIM WARKENTIN

TAX LOT 1000
IN SECTION 35, TOWNSHIP 24 SOUTH, RANGE 18 EAST, W.M.
LAKE COUNTY, OREGON

TAX LOT 2100 AND 2300
IN SECTION 9, TOWNSHIP 25 SOUTH, RANGE 18 EAST, W.M.
LAKE COUNTY, OREGON

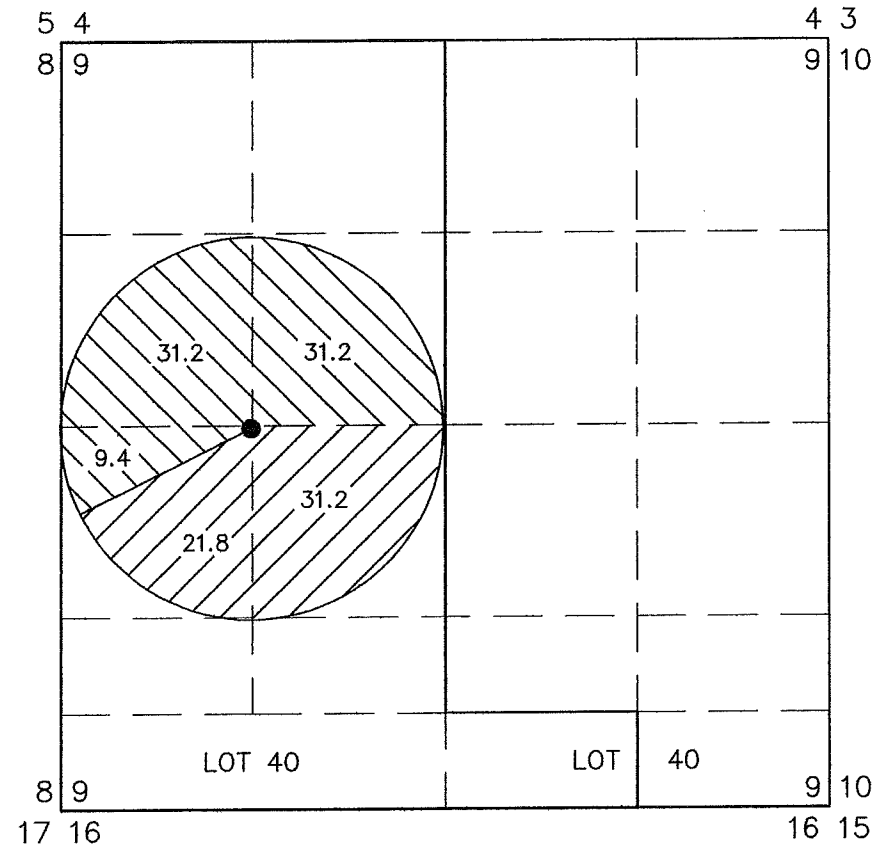
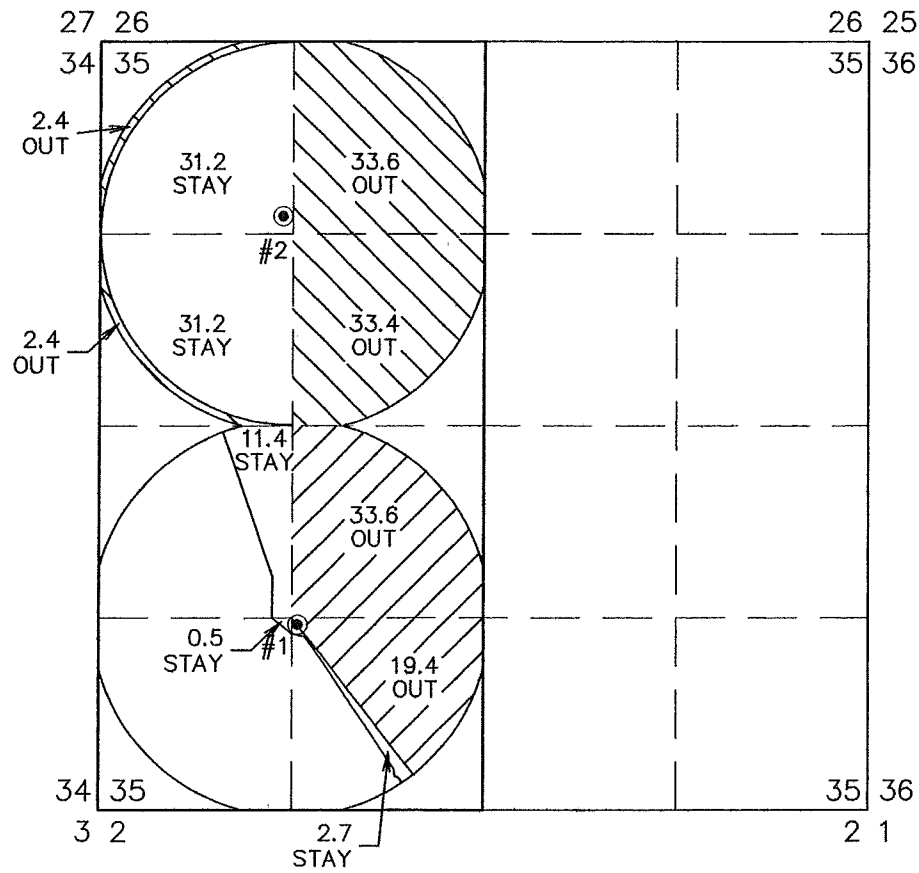

RECEIVED

MAR 22 2010

WATER RESOURCES DEPT
SALEM, OREGON

- #1 WELL LOCATED IN THE SE 1/4 SW 1/4 AND 1275 FEET NORTH AND 1360 FEET EAST FROM THE SW CORNER OF SECTION 35.
- #2 WELL LOCATED IN THE NW 1/4 NW 1/4 AND 1200 FEET SOUTH AND 1250 FEET EAST FROM THE NW CORNER OF SECTION 35.



53.0 ACRES WATER RIGHTS TO BE TRANSFERRED FROM CERTIFICATE No. 80220 (G-10326), AS SHOWN.

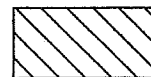

71.8 ACRES WATER RIGHTS TO BE TRANSFERRED FROM CERTIFICATE No. 80221 (G-9974), AS SHOWN.

- P.O.A. WELL LOCATED IN THE NW 1/4 SW 1/4 AND 20 FEET SOUTH AND 1310 FEET EAST FROM THE W 1/4 CORNER OF SECTION 9. WELL TO BE USED IN NEW CONFIGURATION.

THIS MAP IS FOR THE PURPOSE OF LOCATING A WATER RIGHT ONLY AND HAS NO INTENT TO PROVIDE LEGAL DIMENSIONS OR THE LOCATION OF PROPERTY LINES.

T 11037

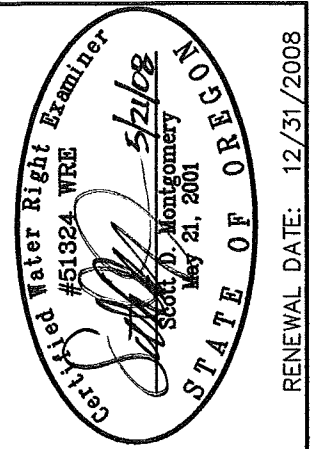

RENEWAL DATE: 12/31/2008

ALL POINTS ENGINEERING
& SURVEYING, INC.

P.O. BOX 767 (CRR)
TERREBONNE, OREGON 97760
(541) 548-5833 PH
(541) 585-4602 FX
www.APEandS.com

PROJECT No. 08-037

PREPARED AT THE REQUEST OF:

TIM WARKENTIN
P.O. BOX 12
CHRISTMAS VALLEY, OR 97641

T.24S., R.18E., W.M.

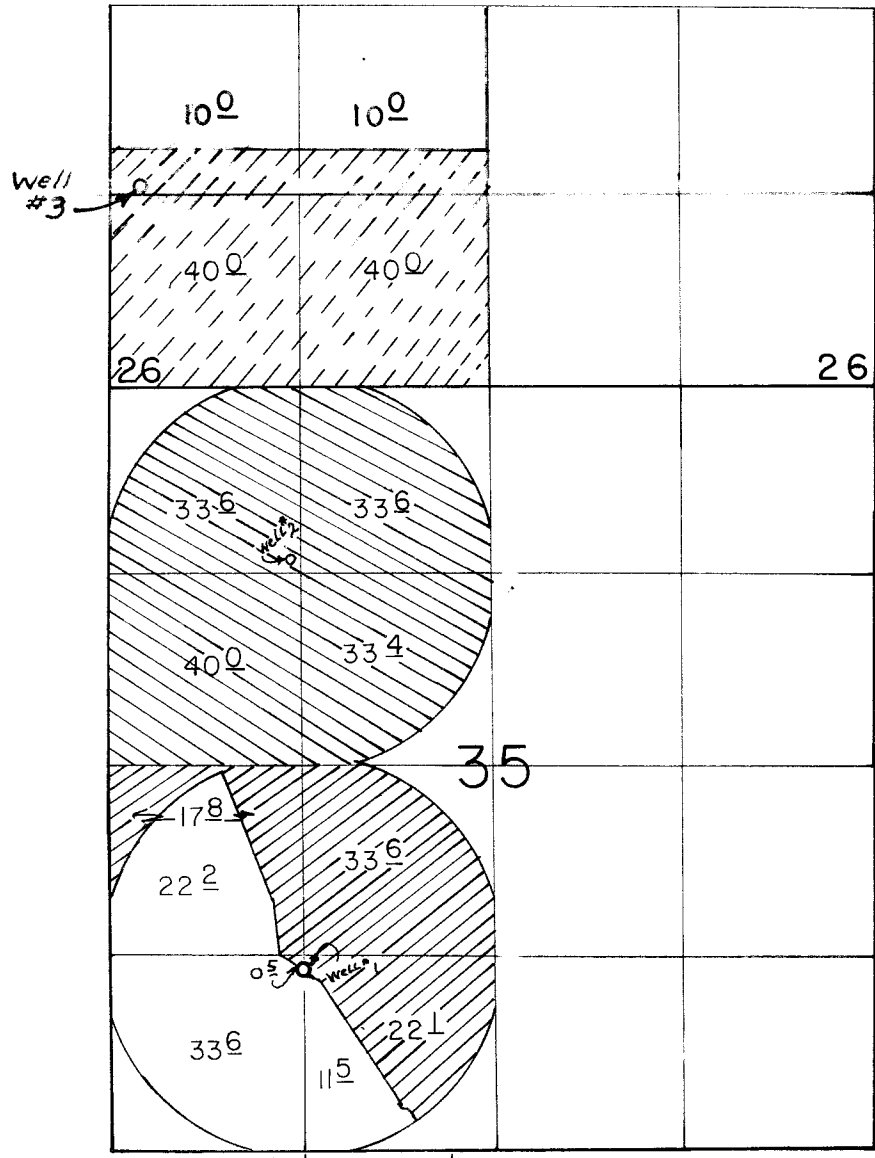

WELL 1, 1250' N & 1320' E FROM SW COR. OF SEC 35.
 WELL 2, 1200' S & 1250' E FROM NW COR. OF SEC 35.
 WELL 3, 1360' N & 200' E FROM SW COR. OF SEC 26.

SCALE: 1" = 1320'

FINAL PROOF SURVEY
 UNDER

CERT. NO. 53148
 Application No. G-11234 Permit No. G-9974
 Application No. G-10366 Permit No. G-10326
 IN NAME OF

HAROLD A. BROWN

Surveyed MAY 8 19 97, by R.M. SUTTERFIELD

RECORDED
 1997
 WATER RESOURCES DIVISION
 CALIFORNIA

P.T.S. 11-7-97
 Revised 5/13/03 DC
 Revised 7/23/02 R.M.S.