

T3&4 N., R. 30 E., W.M.

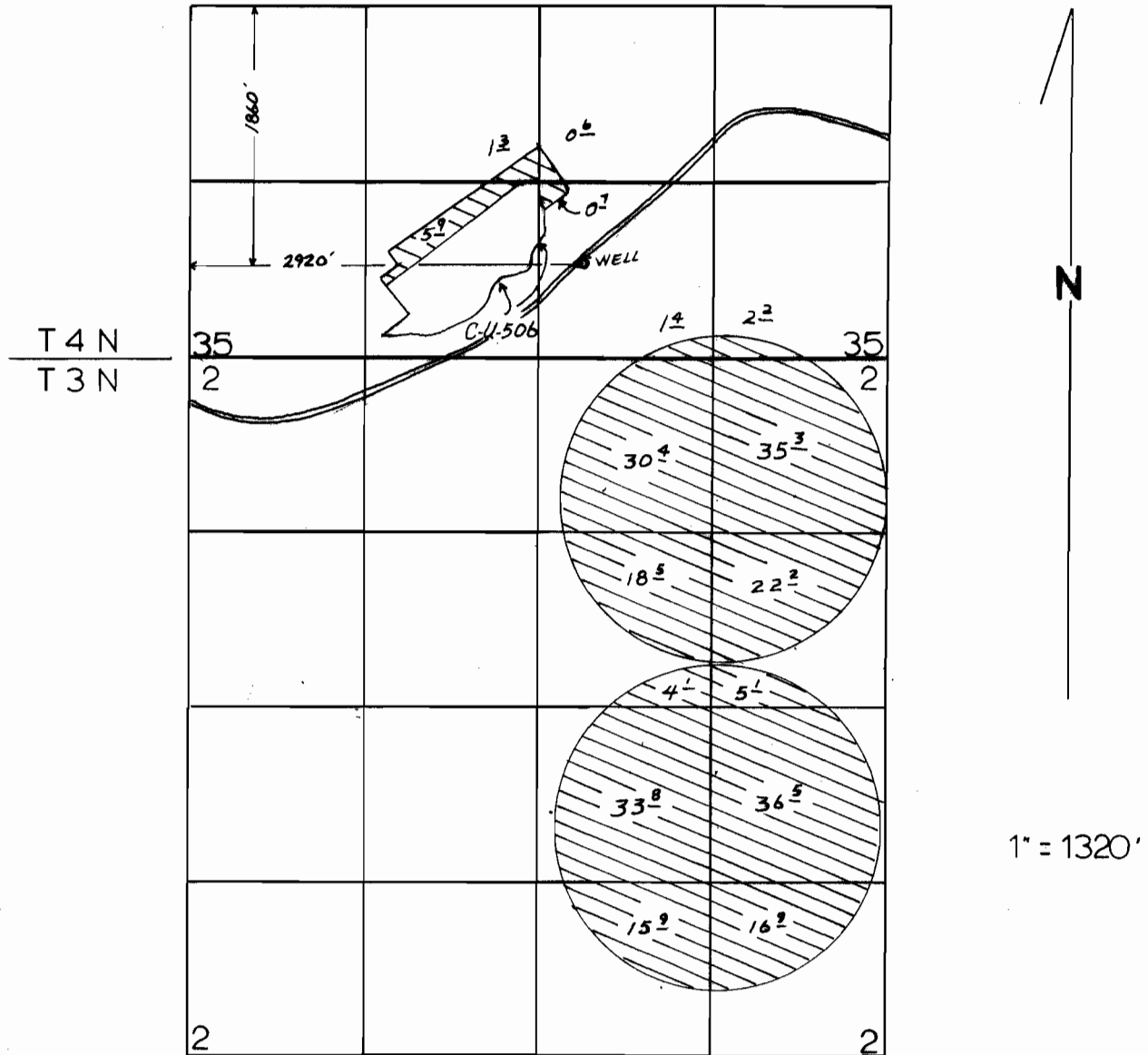

FINAL PROOF SURVEY UNDER

Application No. G-10908 Permit No. G-10067
IN NAME OF

LEONARD A. LORENZEN, LORENZEN RANCHES, INC.

Surveyed 8-6, 1992, by J. MILLER



TODD LONGGOOD
 TRANSFER APPLICATION MAP
 FOR CERT 26074 & A PORTION OF CERT 83134
 T4N, R30E WM SECTION 35; AND T3N, R30E WM SECTION 2
 UMATILLA COUNTY

RECEIVED
 MAR 12 2019
 OWRD

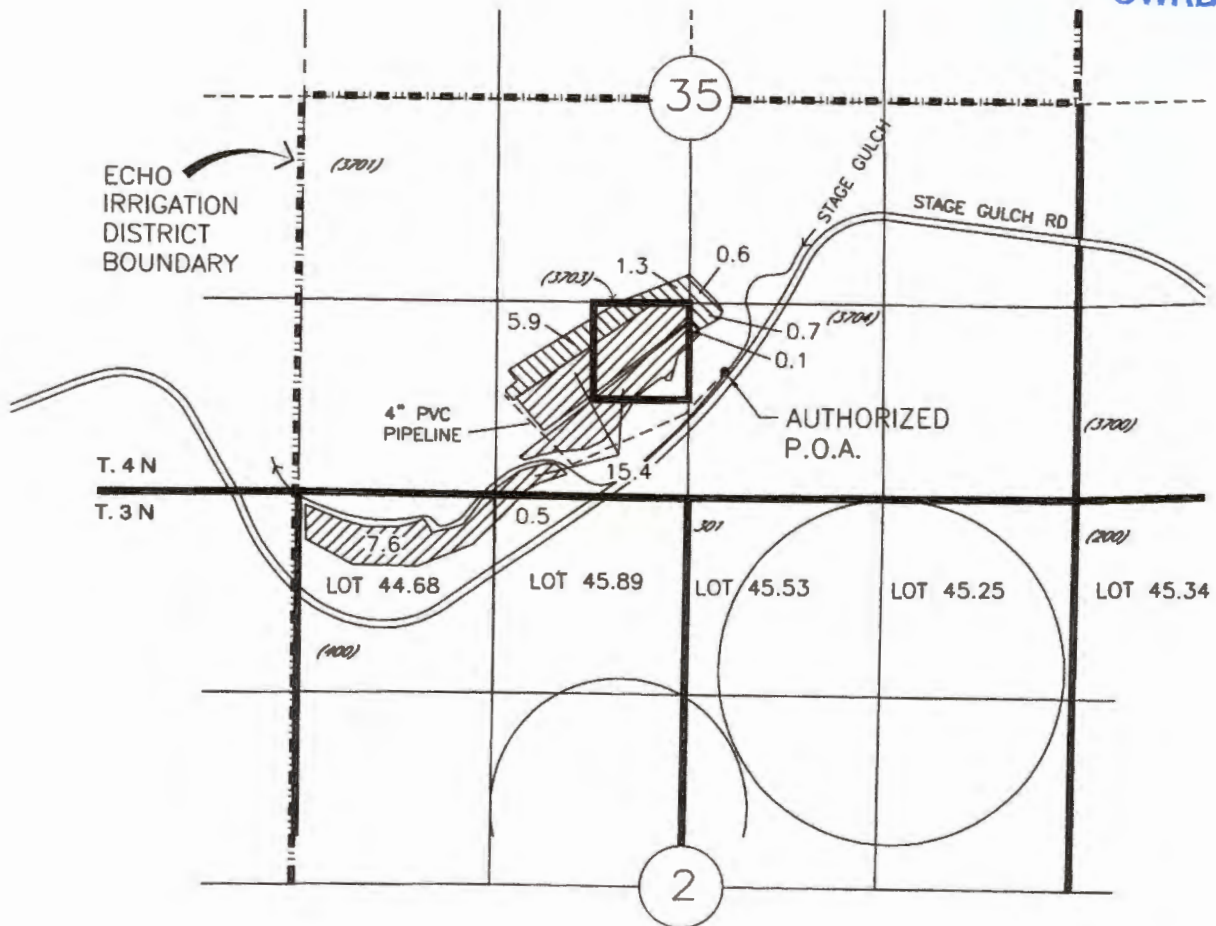
FROM



AUTHORIZED
 P.O.A. WELL LOCATED
 1860' S AND 2920' E FROM THE
 W 1/4 CORNER SECTION 35

-  23.6 AC CERT 26074
-  8.5 AC CERT 83134

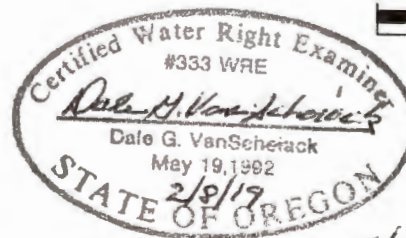

Renews 6/30/19



NOTE:
 THE PURPOSE OF THIS MAP IS TO IDENTIFY THE APPROXIMATE LOCATION
 OF THE WATER RIGHT. IT IS NOT INTENDED TO PROVIDE INFORMATION
 RELATIVE TO THE LOCATION OF PROPERTY OWNERSHIP BOUNDARY LINES.

TODD LONGGOOD
 TRANSFER APPLICATION MAP
 FOR CERT 26074 & A PORTION OF CERT 83134
 T4N, R30E WM SECTION 35; AND T3N, R30E WM SECTION 2
 UMATILLA COUNTY

RECEIVED
 MAR 12 2019
 OWRD

TO

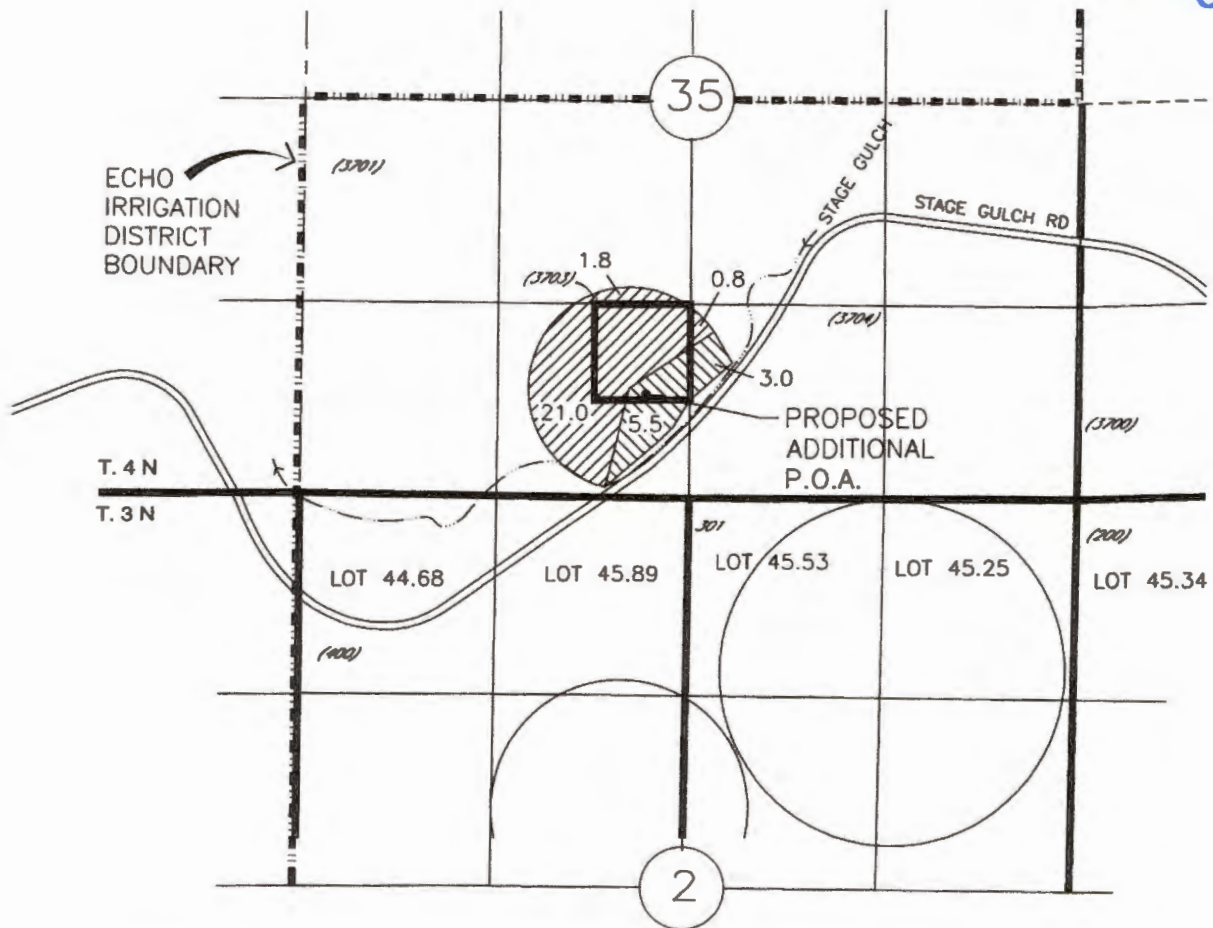

PROPOSED ADDITIONAL
 P.O.A. WELL LOCATED
 2030' S AND 2390' E FROM THE
 W 1/4 CORNER SECTION 35

- 23.6 AC CERT 26074
- 8.5 AC CERT 83134

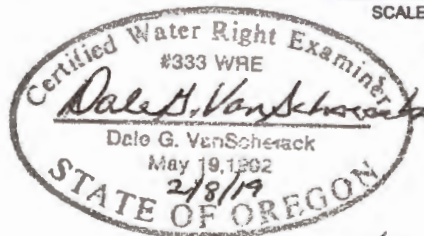

Renew 6/30/19



NOTE:
 THE PURPOSE OF THIS MAP IS TO IDENTIFY THE APPROXIMATE LOCATION
 OF THE WATER RIGHT. IT IS NOT INTENDED TO PROVIDE INFORMATION
 RELATIVE TO THE LOCATION OF PROPERTY OWNERSHIP BOUNDARY LINES.

2017 Google Earth Aerial Photo

Write a description for your map.

Legend

- 3869 ft
- 523 acres
- Canal - 7 miles
- Feature 1
- Feature 2
- Feature 3
- Feature 4
- R30E
- Te Velde Farm - 7189ac

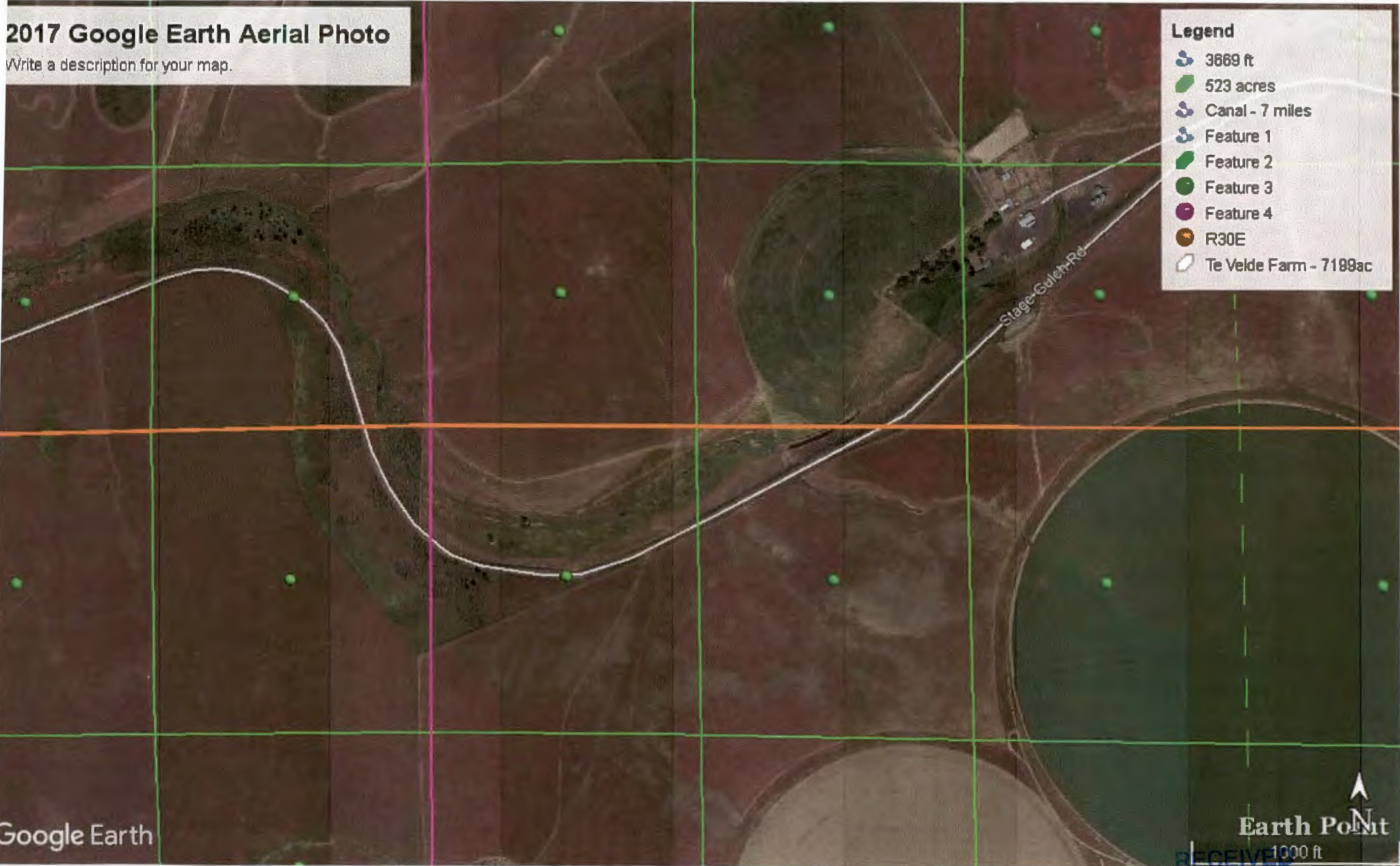

Google Earth

Earth Point
RECEIVED 1000 ft

MAR 12 2019

OWRD