

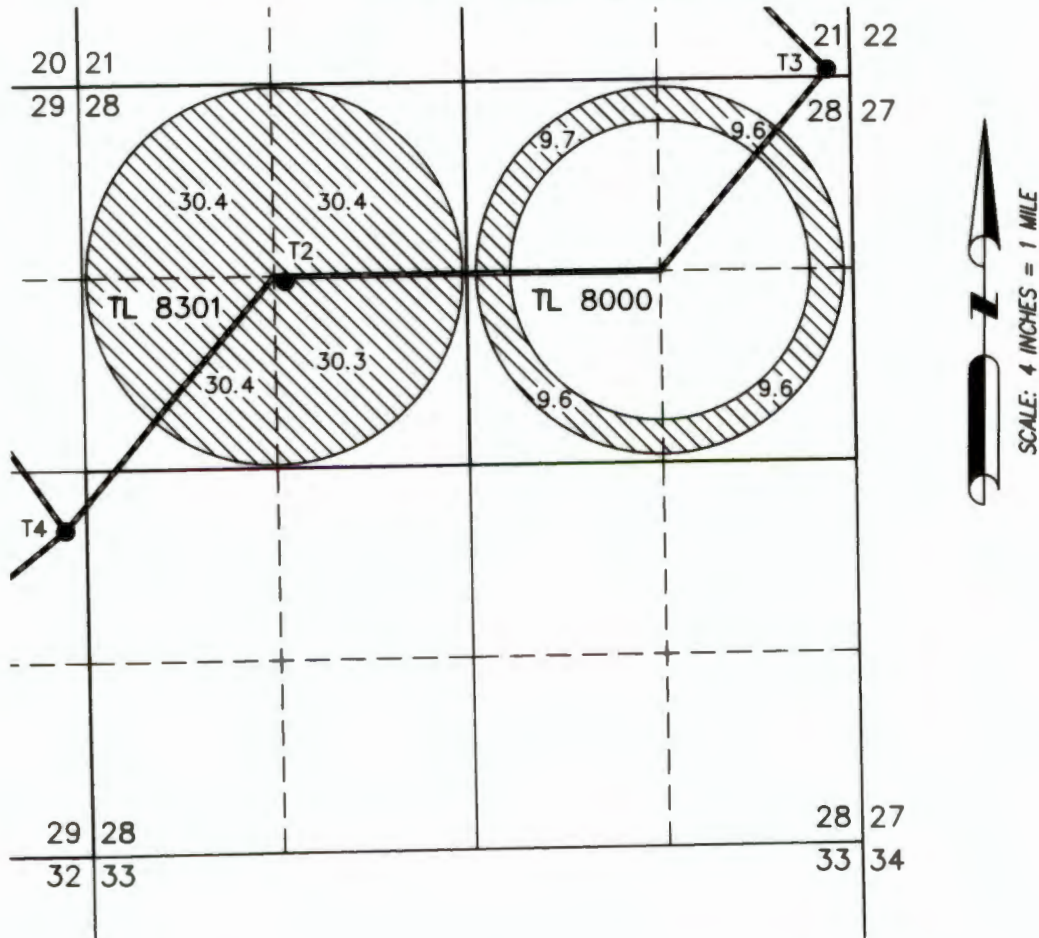

CLAIM OF BENEFICIAL USE MAP

TO ADD PLACE OF USE AND POINTS OF APPROPRIATION
FOR PERMIT APPLICATION G-17242

LOCATED IN THE N 1/2 SECTION 28,
TOWNSHIP 24 SOUTH, RANGE 32.5 EAST, W.M.
TAX LOTS: 8000 & 8301



 160.0 ACRES IR FROM PERMIT G-16676 TO ALL WELLS *, AS SHOWN. RATE 1/80 CFS/ACRE DUTY 3.0 AF/ACRE

* SEE SEPERATE INCLUDED MAP SHOWING THE LOCATIONS OF ALL WELLS SUPPLYING THE PLACE OF USE.

THIS MAP IS FOR THE PURPOSE OF LOCATING A WATER RIGHT ONLY AND HAS NO INTENT TO PROVIDE LEGAL DIMENSIONS OR THE LOCATION OF PROPERTY LINES

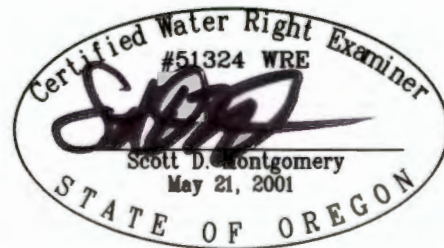

RENEWAL DATE: 12/31/2020

PREPARED FOR:

JESSE VAN DE STROET
1524 290TH STREET
INWOOD, IA 51240-8006

PREPARED BY:



ALL POINTS ENGINEERING AND SURVEYING, INC.
P.O. BOX 767 TERREBONNE, OR 97760
(541) 548-5833 www.APEandS.com

CLAIM OF BENEFICIAL USE MAP

MAP TO ILLUSTRATE LOCATIONS OF WELLS FOR APPLICATION T-13188

SECTIONS 20, 21, 28, & 29,
TOWNSHIP 24 SOUTH, RANGE 32.5 EAST, W.M.
TAX LOTS: 500, 8000, 8301, & 9900

RECEIVED

OCT 26 2020

OWRD

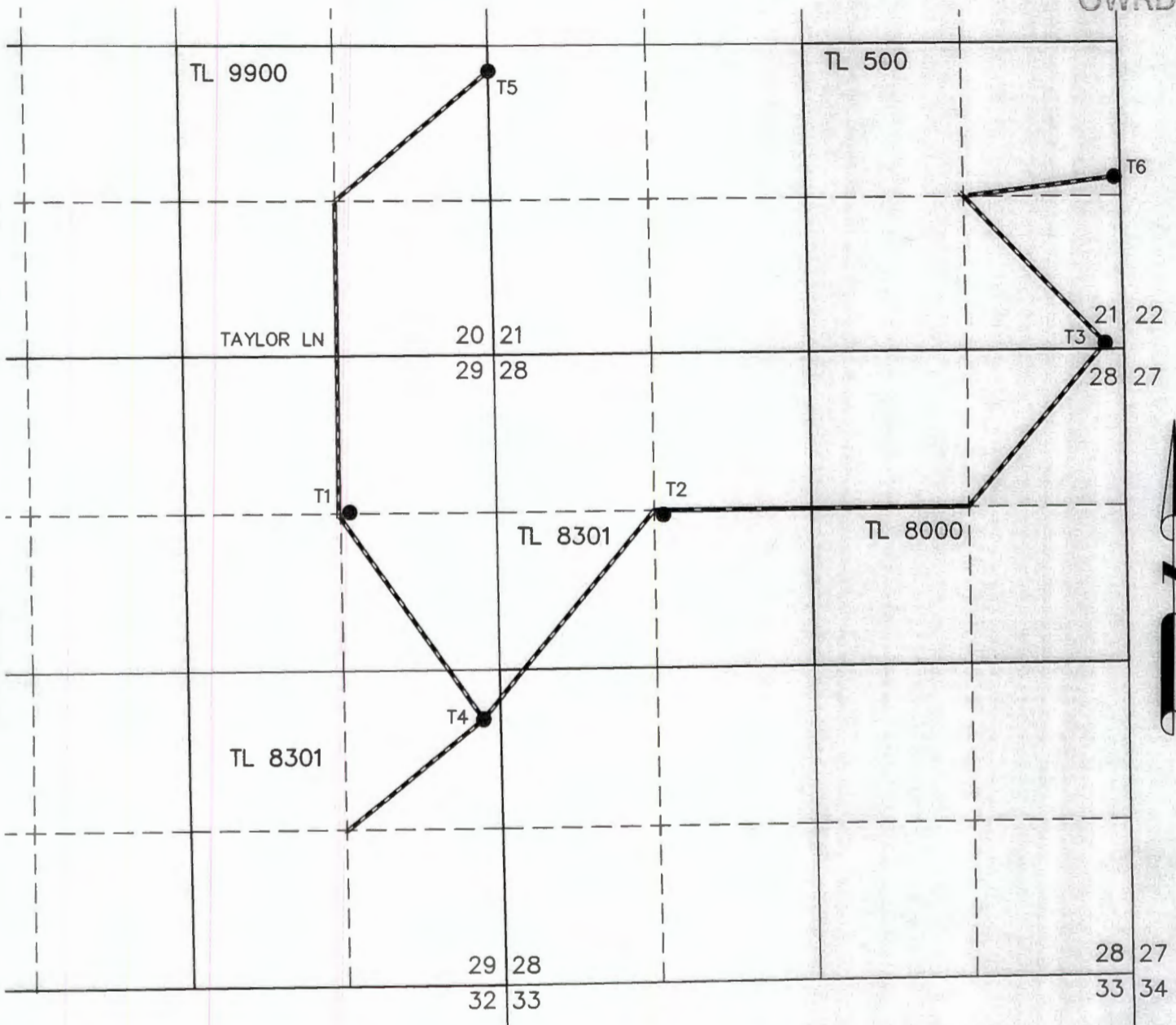

- T1 OR GUND2 (HARN 52215)
LOCATED IN THE NE 1/4 NE 1/4 SECTION 29, T24S R32.5E, W.M. AND 1335 FEET NORTH AND 1395 FEET EAST FROM THE C 1/4 CORNER OF SECTION 29. FLOW METER LOCATED 7' NORTH FROM WELL.
- T2 OR GREG3 (HARN 51944)
LOCATED IN THE SE 1/4 NW 1/4 SECTION 28, T24S R32.5E, W.M. AND 1355 FEET SOUTH AND 1400 FEET EAST FROM THE NW CORNER OF SECTION 28. FLOW METER LOCATED 8' SOUTH FROM CENTER PIVOT SPRINKLER.
- T3 (HARN 52491)
LOCATED IN THE SE 1/4 SE 1/4 SECTION 21, T24S R32.5E, W.M. AND 50 FEET NORTH AND 160 FEET WEST FROM THE SE CORNER OF SECTION 21. FLOW METER LOCATED 7' NW FROM WELL.
- T4 OR GUND4 (HARN 52624)
LOCATED IN THE NE 1/4 SE 1/4 SECTION 29, T24S R32.5E, W.M. AND 410 FEET SOUTH AND 2490 FEET EAST FROM THE C 1/4 CORNER OF SECTION 29. FLOW METER LOCATED 5' NORTH FROM WELL.
- T5 OR CULP1 (HARN 50789)
LOCATED IN THE NE 1/4 NE 1/4 SECTION 20, T24S R32.5E, W.M. AND 2258 FEET NORTH AND 2609 FEET EAST FROM THE S 1/4 CORNER OF SECTION 20. FLOW METER LOCATED 4.5' SW FROM WELL.
- T6 OR CULP2 (HARN 50285)
LOCATED IN THE NE 1/4 SE 1/4 SECTION 21, T24S R32.5E, W.M. AND 1120 FEET SOUTH AND 50 FEET WEST FROM THE E 1/4 CORNER OF SECTION 21. FLOW METER LOCATED 4' WEST FROM WELL.

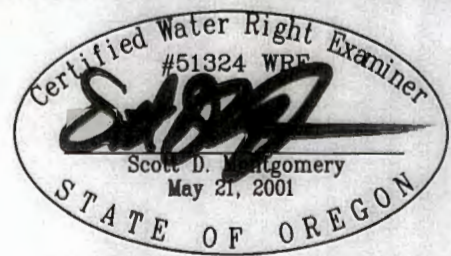

RENEWAL DATE: 12/31/2020

THIS MAP IS FOR THE PURPOSE OF LOCATING A WATER RIGHT ONLY AND HAS NO INTENT TO PROVIDE LEGAL DIMENSIONS OR THE LOCATION OF PROPERTY LINES

<p>PREPARED FOR:</p> <p>JESSE VAN DE STROET 1524 290TH STREET INWOOD, IA 51240-8006</p>	<p>PREPARED BY:</p> <div style="display: flex; align-items: center;"> <div> <p>ALL POINTS ENGINEERING AND SURVEYING, INC. P.O. BOX 767 TERREBONNE, OR 97760 (541) 548-5833 www.APEandS.com</p> </div> </div>
---	---