

968

CORU MAP # 968

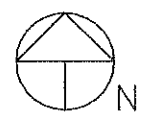

Scale: 1"=400'

LEGEND

- Survey Monument
- Denotes Building
- ⊙ Denotes Well
- Ⓜ Denotes Flow Meter
- - - Denotes Pipeline
- ▨ Denotes Area Irrigated Under Permit G-15803, Priority Date April 27, 2004

CLAIM OF BENEFICIAL USE MAP
 APPLICATION G-16235 - PERMIT G-15803
 SITUATED IN
 GOVT. LOTS 3 AND 4, SECTION 30
 TOWNSHIP 37 SOUTH, RANGE 4 WEST
 WILLAMETTE MERIDIAN, JACKSON COUNTY, OREGON
 FOR
 PATRICIA S. KELLOGG
 1070 KUBLI ROAD, GRANTS PASS, OR 97527

Source:

P.O.A.1, Well L-13410 situated 51.0' South and 795.0' East of 'L' corner of DLC No. 40, T.37S., R.4W.
 P.O.A.2, Well L-13411 situated 226.0' South and 994.0' East of 'L' corner of DLC No. 40, T.37S., R.4W.

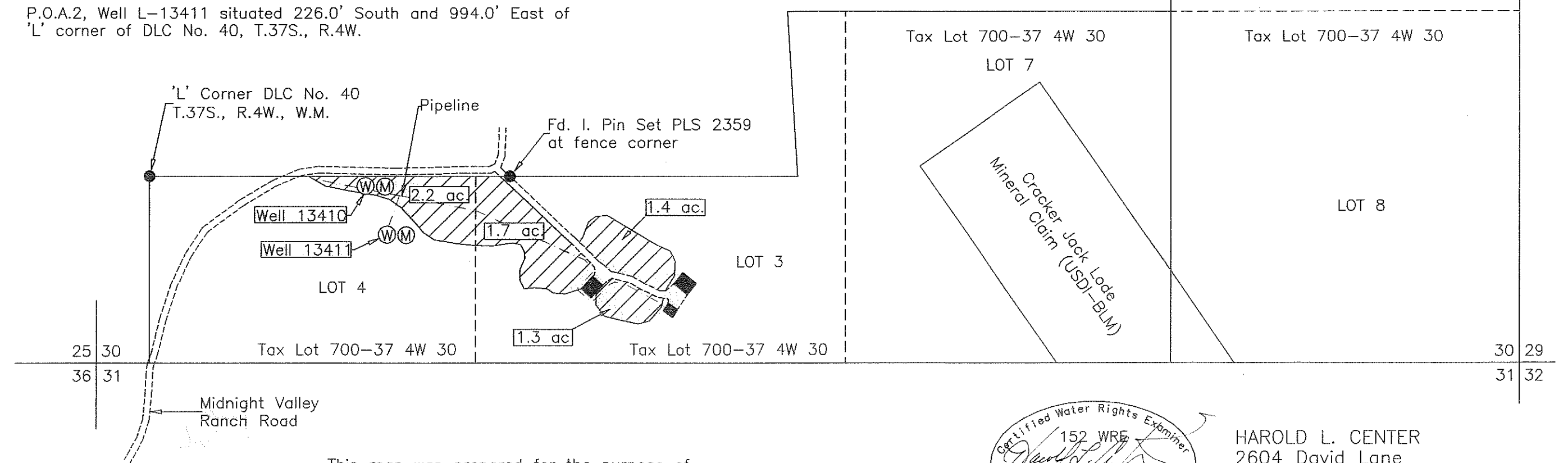

This map was prepared for the purpose of identifying the location of a water right only and is not intended to provide legal dimensions or location of property ownership.

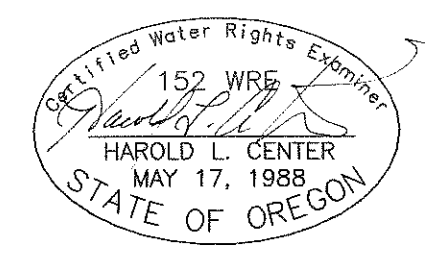

HAROLD L. CENTER
 2604 David Lane
 Medford, OR. 97504
 Phone 541-535-6108
 Oregon Certificate No. 152

Renews: 12/31/17