

CLAIM OF BENEFICIAL USE MAP

TO CHANGE POINTS OF APPROPRIATION &
PLACE OF USE FOR TRANSFER, T-13246
SCOTT & JOSE TOBIASSON

TOWNSHIP 25 SOUTH, RANGE 15 EAST, SECTION 33, W.M.
TAX LOT: 1800

RECEIVED

JUL 29 2022

OWRD

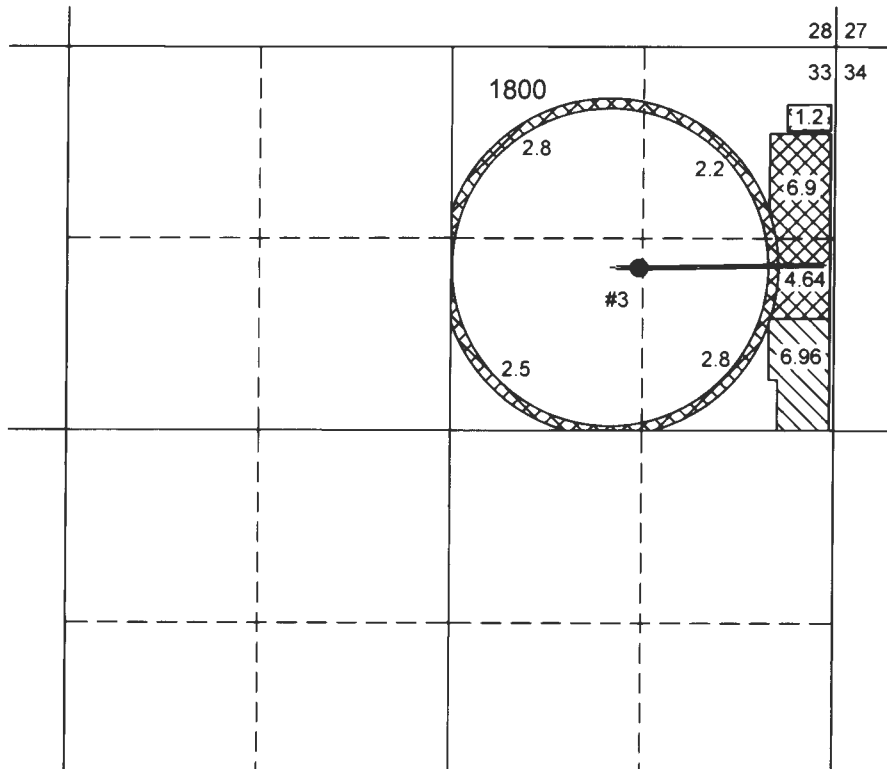

23.04 ACRES IR AUTHORIZED
FROM #3 BY T-13359.



6.96 ACRES IR AUTHORIZED FROM
#3 BY T-13246.

BURIED CONVEYANCE

● #3 (LAKE 188)

LOCATED IN THE SW 1/4 NE 1/4 SECTION 33, T25S R15E,
W.M. AND 1120 FEET NORTH AND 1350 FEET WEST FROM THE
E 1/4 CORNER OF SECTION 33.

FLOW METER IS LOCATED ON THE CENTER PIVOT SPRINKLER &
200 FEET WEST FROM THE WELL.

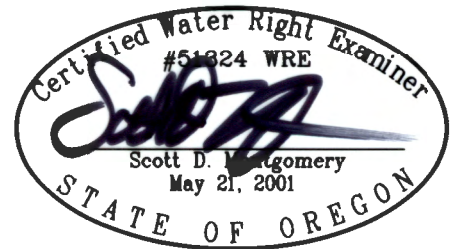

RENEWAL DATE: 12/31/2022

THIS MAP IS FOR THE PURPOSE OF LOCATING A WATER
RIGHT ONLY AND HAS NO INTENT TO PROVIDE LEGAL
DIMENSIONS OR THE LOCATION OF PROPERTY LINES.

PREPARED FOR:

SCOTT TOBIASSON
P.O. BOX 93
FT. ROCK, OR 97735

PREPARED BY:



ALL POINTS ENGINEERING AND SURVEYING, INC.
P.O. BOX 767 TERREBONNE, OR 97760
(541) 548-5833 www.APEandS.com