

T3S., R3W., W.M. AND T4S., R3W., W.M.

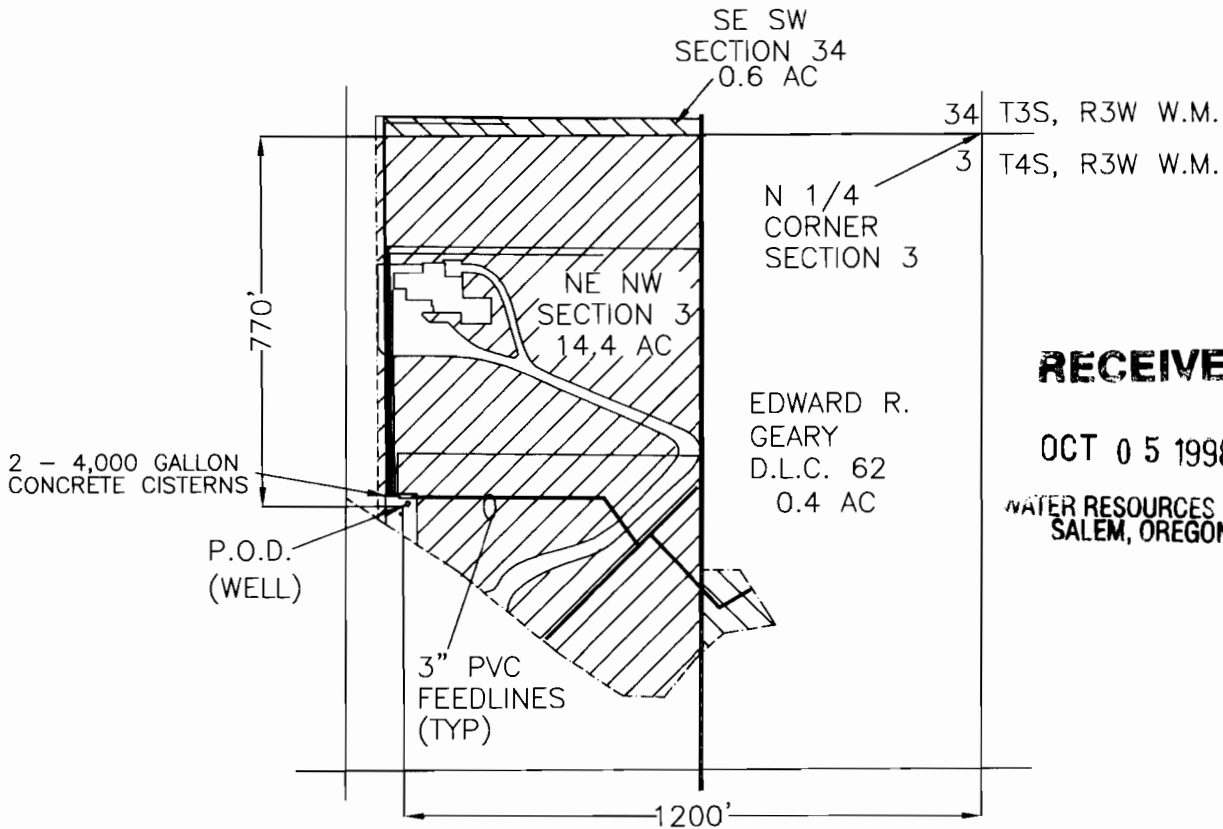

RECEIVED

OCT 05 1998

WATER RESOURCES DEPT.
SALEM, OREGON

CLAIM OF BENEFICIAL USE MAP
FOR PINE RIDGE ASSOCIATES
TAX LOT 4 3 03 02500
IN SW 1/4 SECTION 34, T3S., R3W., W.M.
AND
NW 1/4 SECTION 3, T4S., R3W., W.M.
YAMHILL COUNTY, OREGON
APPLICATION: G-13643
PERMIT: G-11888

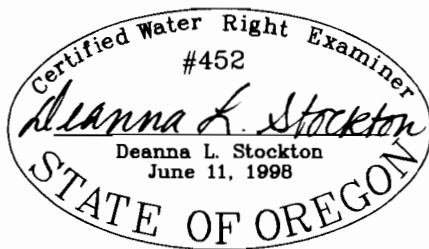

EXPIRES 06/30/2000

SCALE: 1" = 400'



SURVEYED: SEPTEMBER 9, 1998

THIS MAP IS FOR THE PURPOSE
OF IDENTIFYING THE LOCATION OF
THE WATER RIGHT ONLY AND IS
NOT INTENDED TO PROVIDE LEGAL
DIMENSIONS OR THE LOCATION
OF PROPERTY OWNERSHIP LINES.