

# FINAL PROOF SURVEY

PERMIT G-12341, APPLICATION G-13256  
TO APPROPRIATE PUBLIC WATERS

FOR A PARCEL OF LAND SITUATED IN THE NE 1/4, NW 1/4 AND THE NW 1/4, NE 1/4,  
SECTION 4, TOWNSHIP 15 SOUTH, RANGE 10 EAST, WILLAMETTE MERIDIAN, DESCHUTES COUNTY, OREGON

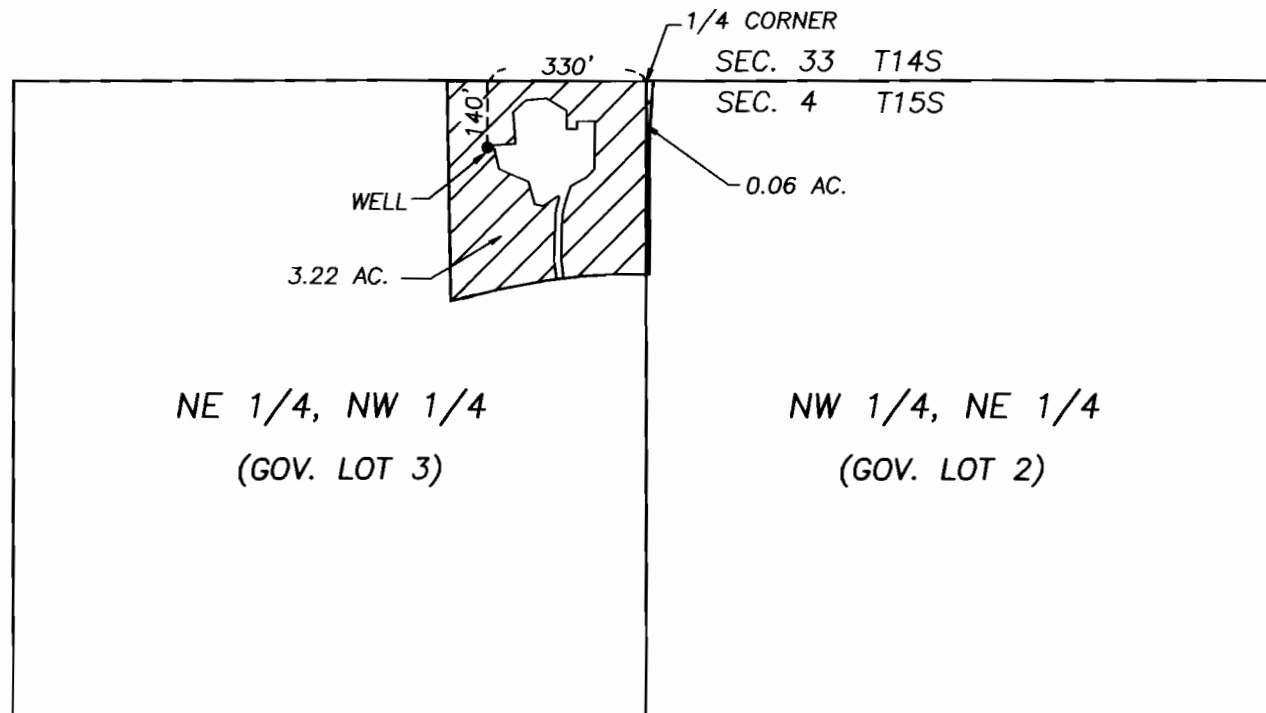

T15S, R10E, W.M.  
DESCHUTES COUNTY, OR

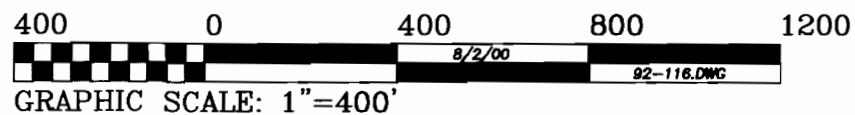

THIS MAP IS FOR THE PURPOSE OF IDENTIFYING THE LOCATION OF THE WATER RIGHT.  
IT IS NOT INTENDED TO PROVIDE LEGAL DIMENSIONS OR LOCATIONS OF PROPERTY  
OWNERSHIP LINES.