

**WATER USE APPLICATION MAP
FOR
STRUAN LLC (JcBio)
LOCATED IN THE NE 1/4 OF THE NW 1/4 OF SEC. 17, TOWNSHIP 16
SOUTH, RANGE 4 WEST, W.M., LANE COUNTY, OREGON**

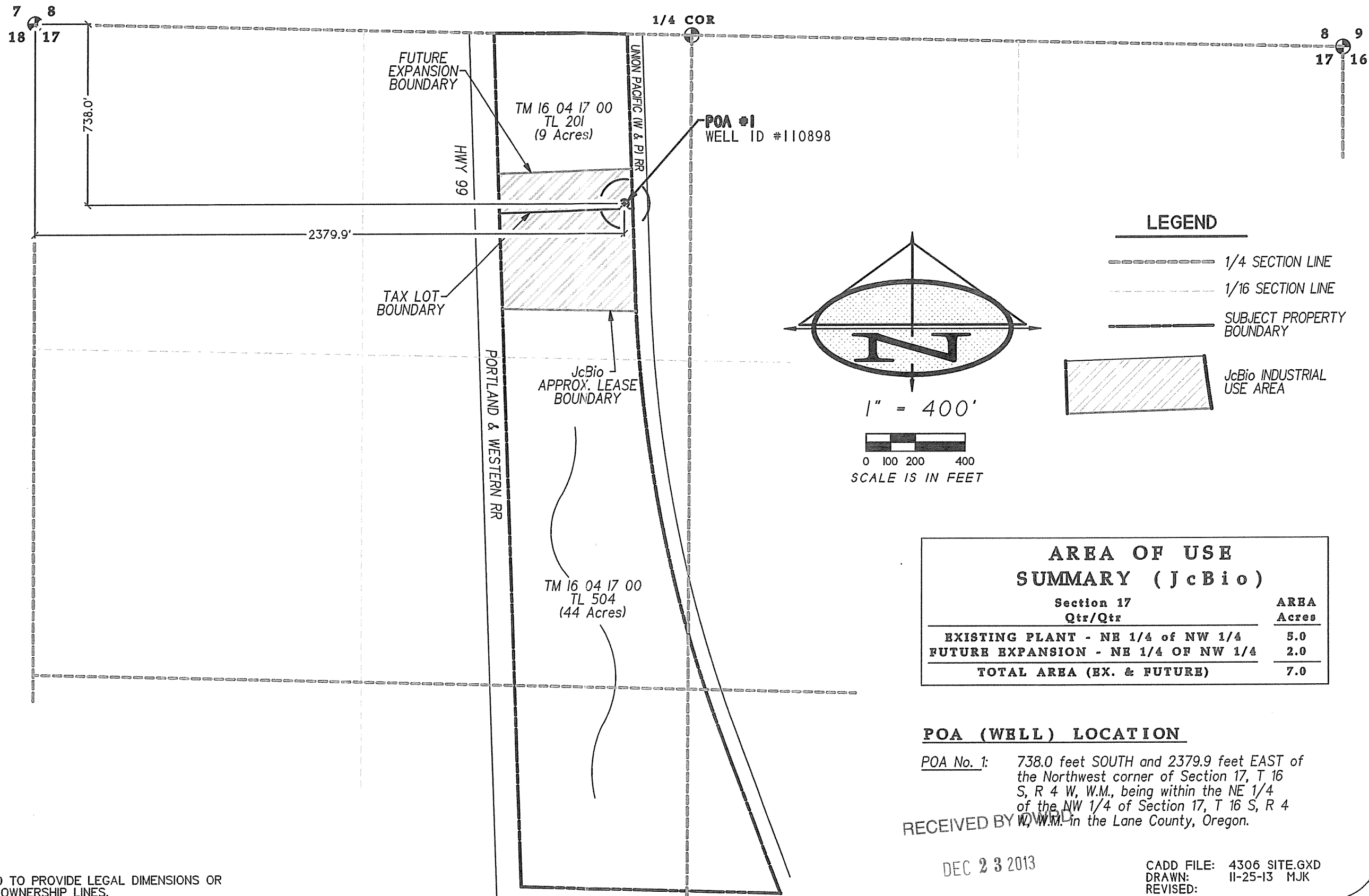

LEGEND

- 1/4 SECTION LINE
- 1/16 SECTION LINE
- SUBJECT PROPERTY BOUNDARY
- JcBio INDUSTRIAL USE AREA

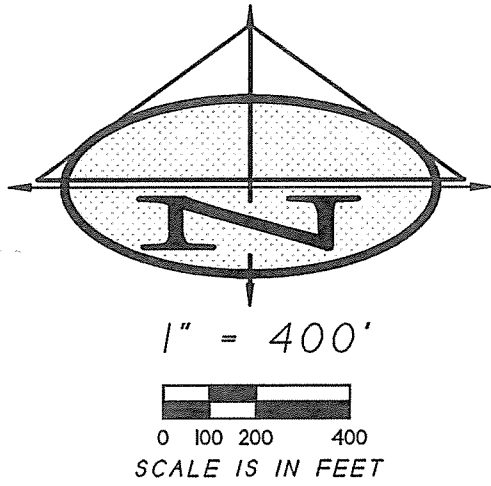

AREA OF USE SUMMARY (JcBio)	
Section 17 Qtr/Qtr	AREA Acres
EXISTING PLANT - NE 1/4 of NW 1/4	5.0
FUTURE EXPANSION - NE 1/4 OF NW 1/4	2.0
TOTAL AREA (EX. & FUTURE)	7.0

POA (WELL) LOCATION

POA No. 1: 738.0 feet SOUTH and 2379.9 feet EAST of the Northwest corner of Section 17, T 16 S, R 4 W, W.M., being within the NE 1/4 of the NW 1/4 of Section 17, T 16 S, R 4 W, W.M. in the Lane County, Oregon.

RECEIVED BY W.W.M.

DEC 23 2013

CADD FILE: 4306 SITE.GXD
DRAWN: 11-25-13 MJK
REVISED:

THIS MAP IS NOT INTENDED TO PROVIDE LEGAL DIMENSIONS OR LOCATIONS OF PROPERTY OWNERSHIP LINES.

SALEM, OR

G-17747