

AMENDED APPLICATION MAP

G-17686

FOR FITZGERALD RANCH

RECEIVED

TAX LOTS 3400, 3500 & 3800
IN SECTIONS 16 & 17, TOWNSHIP 36 SOUTH, RANGE 24 EAST, W.M.
LAKE COUNTY, OREGON

JUN 25 2018

OWRD

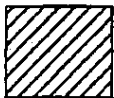
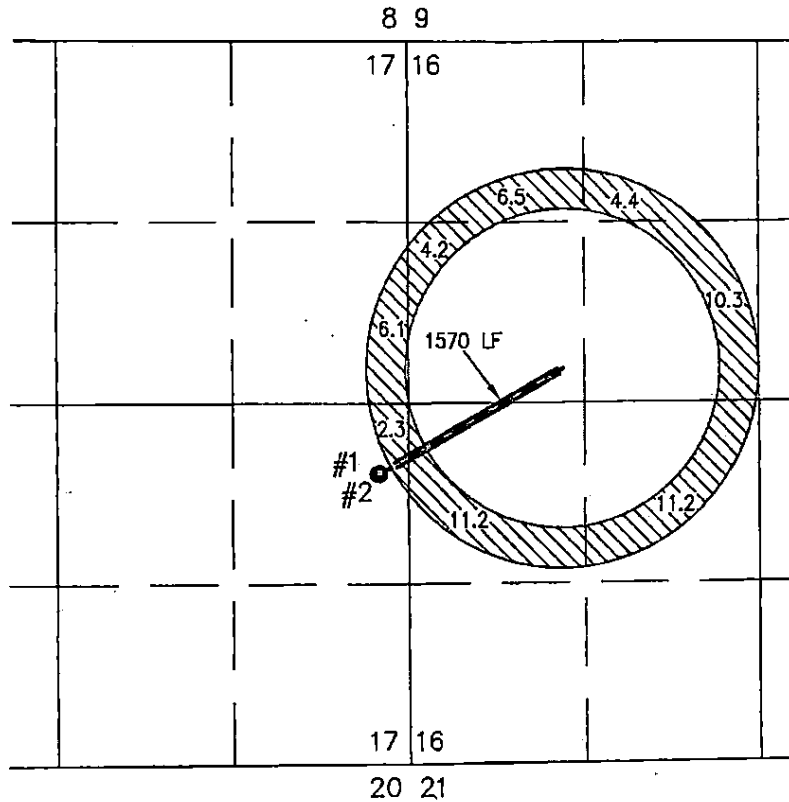

56.2 ACRES PRIMARY IRRIGATION
FROM WELL 2, AS SHOWN

- WELL #2 PROPOSED IN THE NE 1/4 OF THE SE 1/4 SECTION 17 & 2145' NORTH & 235' WEST FROM THE SE CORNER SECTION 17.

— — — — —
BURIED 6 OR 8 INCH STEEL PIPE

PROJECT No. 16-073

PREPARED AT THE REQUEST OF:
FITZGERALD RANCH, INC.
27493 PLUSH-ADEL ROAD
PLUSH, OR 97637

ALL POINTS ENGINEERING & SURVEYING, INC.



P.O. BOX 767
TERREBONNE, OREGON 97760
(541) 548-5833 PH
Scott@APEandS.com
www.APEandS.com