

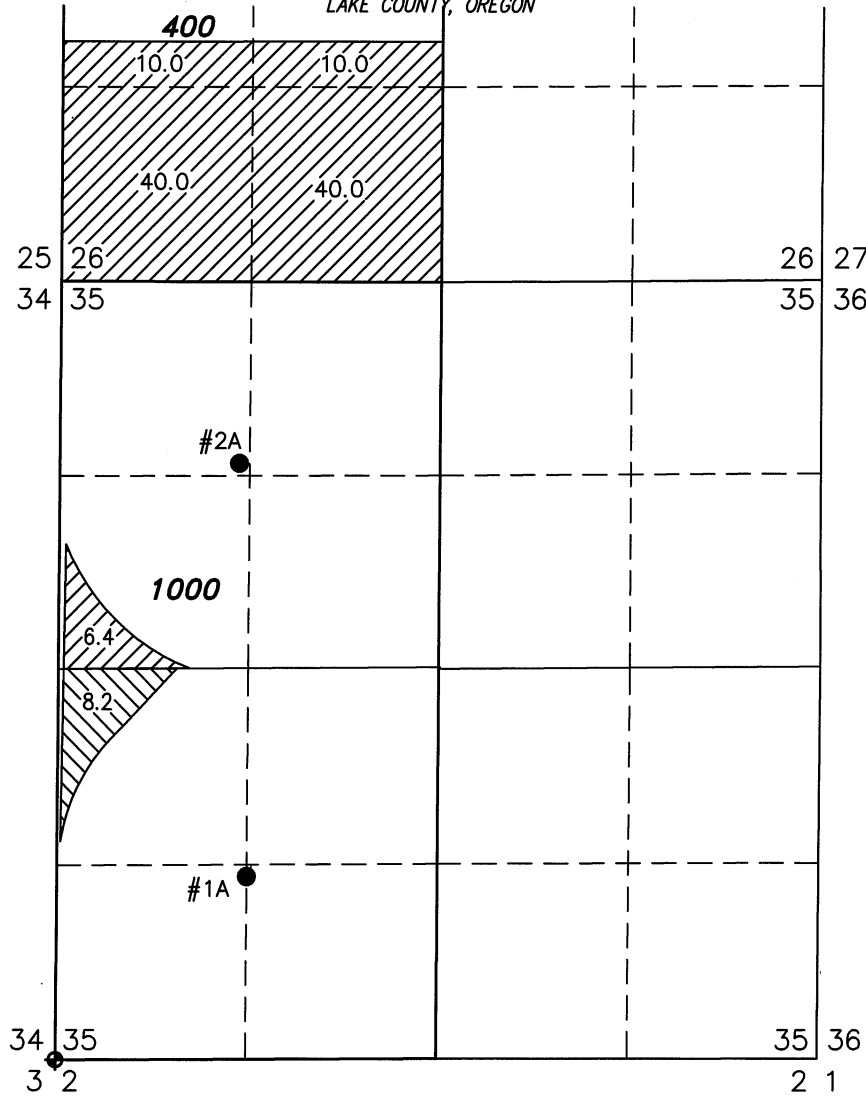

MAP TO ACCOMPANY APPLICATION
TO CHANGE PLACE OF USE
AND ADD A POINT OF APPROPRIATION
FOR
3 JS FAMILY FARMS

"FROM" TAX LOTS 400, & 1000
IN SECTIONS 26 & 35, TOWNSHIP 24 SOUTH, RANGE 18 EAST,
W.M.
LAKE COUNTY, OREGON



- #1A WELL LOCATED IN THE SW 1/4 SW 1/4 SECTION 35, T24S R18E, W.M. LOCATED 1250 FEET NORTH AND 1320 FEET EAST FROM THE SW CORNER OF SECTION 35.
- #2A WELL LOCATED IN THE NW 1/4 NW 1/4 SECTION 35, T24S R18E, W.M. LOCATED 1200 FEET SOUTH AND 1250 FEET EAST FROM THE NW CORNER OF SECTION 35.

 106.4 ACRES WATER RIGHTS FROM CERTIFICATE #86891 (G-9974), TRANSFERRED AS SHOWN.

 8.2 ACRES WATER RIGHTS FROM CERTIFICATE #86890 (G-10326), AS SHOWN.



THIS MAP IS FOR THE PURPOSE OF LOCATING A WATER RIGHT ONLY AND HAS NO INTENT TO PROVIDE LEGAL DIMENSIONS OR THE LOCATION OF PROPERTY LINES.

"TO" TAX LOT 800
IN SECTION 8, TOWNSHIP 26 SOUTH, RANGE 18 EAST, W.M.
LAKE COUNTY, OREGON

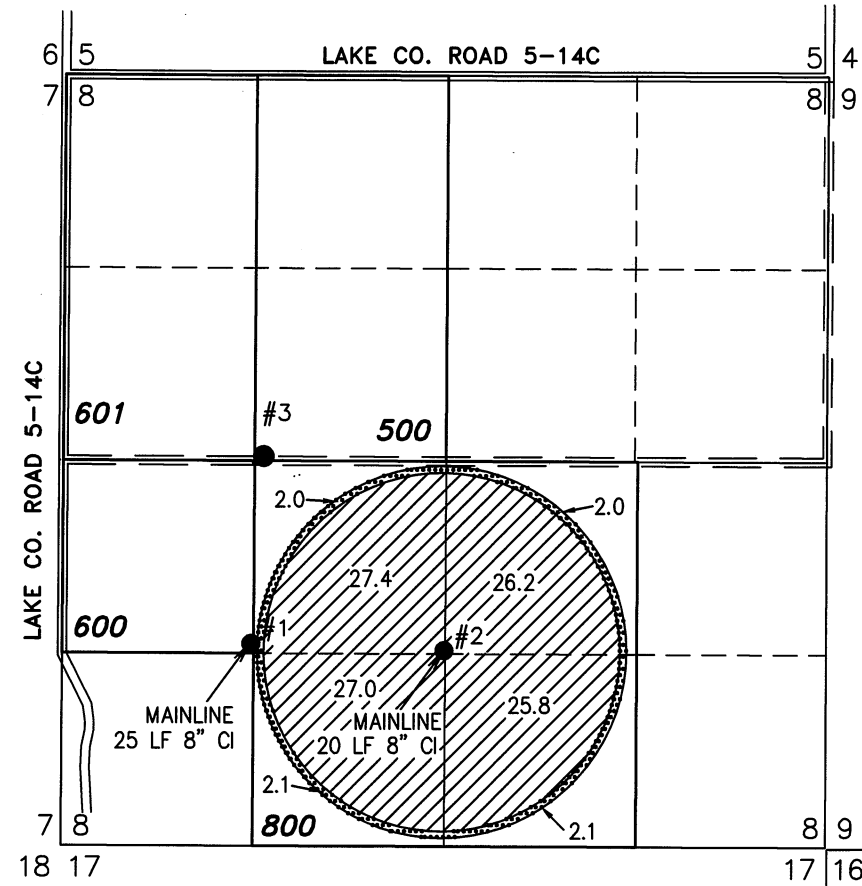

- #2 WELL LOCATED IN THE NW 1/4 SE 1/4 SECTION 8, T26S R18E, W.M. LOCATED 1347 FEET NORTH AND 2613 FEET WEST FROM THE SE CORNER OF SECTION 8.

 106.4 ACRES WATER RIGHTS FROM CERTIFICATE #86891 (G-9974), AS SHOWN.

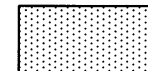
 8.2 ACRES WATER RIGHTS FROM CERTIFICATE #86890 (G-10326), AS SHOWN.

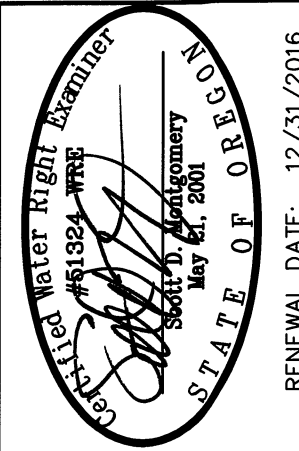

ALL POINTS ENGINEERING
& SURVEYING, INC.

P.O. BOX 767
TERREBONNE, OREGON 97760
(541) 548-5833 PH
Scott@APEandS.com
www.APEandS.com

PROJECT No. 14-079
PREPARED AT THE REQUEST OF:
3 JS FAMILY FARMS
P.O. BOX 12
CHRISTMAS VALLEY, OR 97641