

CANYON FARM II, LLC CLAIM OF BENEFICIAL USE MAP FOR T-13266
 FORMER CERTIFICATES 80062, 83517, 86992, 86993, 86856 & 86857
 T2N & T3N R26EWM

OVERALL

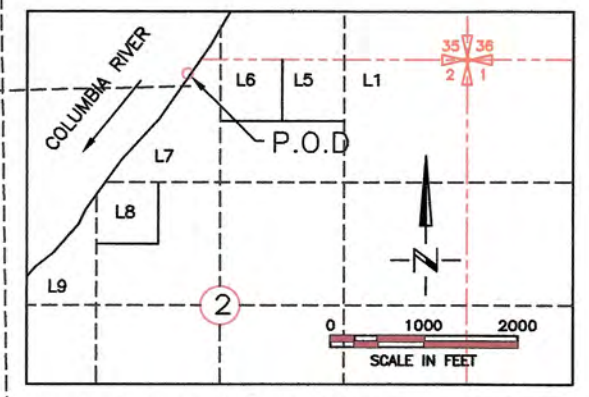

P.O.D. LOCATED 150' SOUTH AND 2990' WEST FROM THE NE CORNER OF SECTION 2, T4N, R25E WM

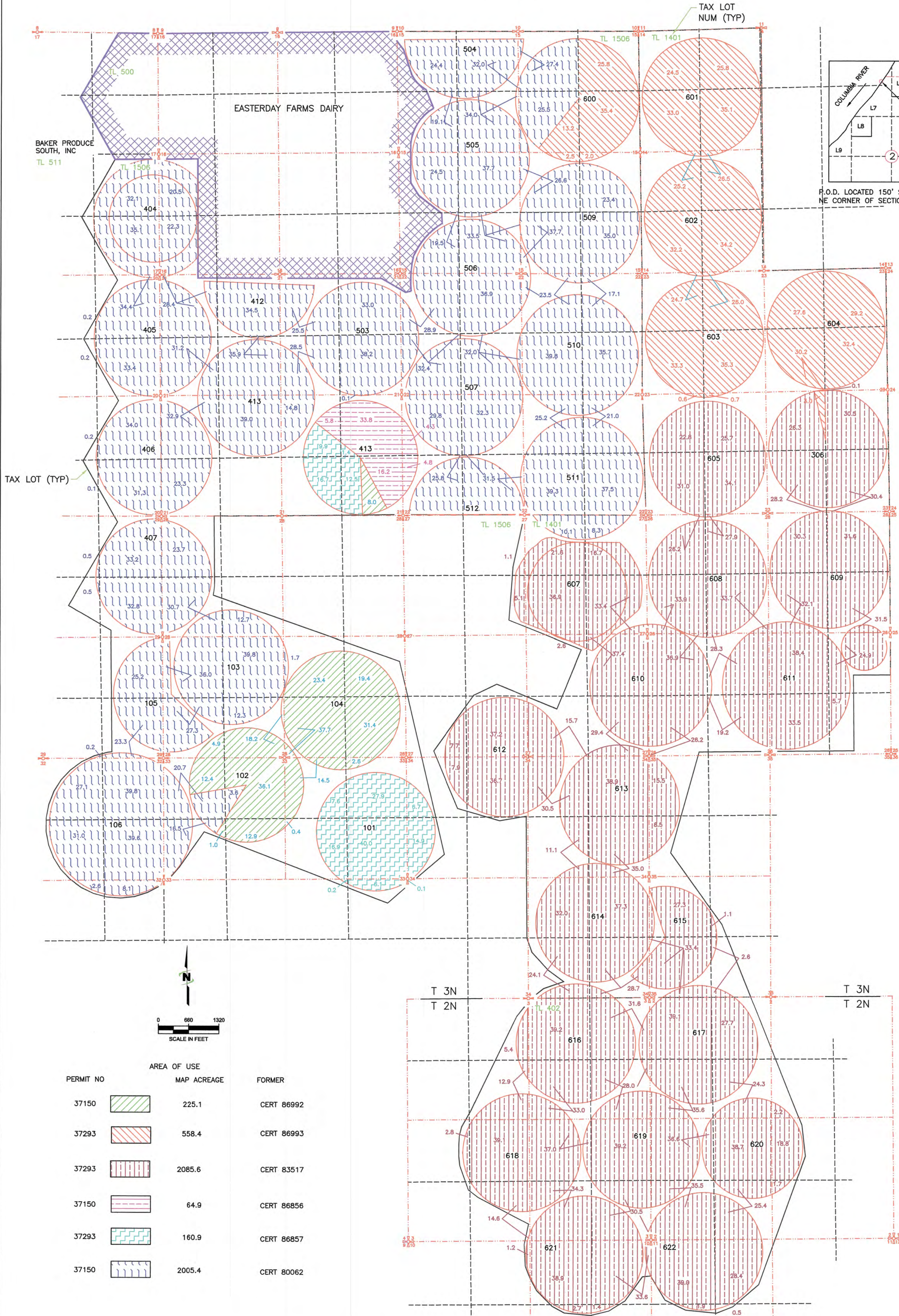
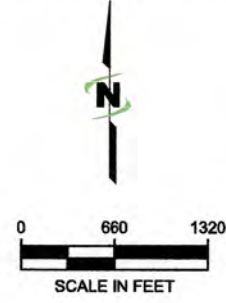

PERMIT NO	AREA OF USE MAP ACREAGE	FORMER
37150	225.1	CERT 86992
37293	558.4	CERT 86993
37293	2085.6	CERT 83517
37150	64.9	CERT 86856
37293	160.9	CERT 86857
37150	2005.4	CERT 80062

RECEIVED
 AUG 17 2020
 OWRD
 RECEIVED
 AUG 17 2020
 OWRD

PUMP STA 4A
 WATER RIGHT - 9,125 GPM
 PUMP TAG RATINGS
 1 - 300 HP, 3,400 GPM
 2 - 200 HP, 2,325 GPM
 TOTAL = 9,125 GPM @ 280 TDH (121 PSI)
 ELEV = 635 FT
 NORMAL MAX PRESSURE = 100 PSI
 HGL = 866 FT

PUMP STATION 5
 WATER RIGHT - 13,000 GPM
 PUMP TAG RATINGS
 1 - 200 HP, 2,160 GPM
 1 - 300 HP, 3,150 GPM
 1 - 400 HP, 4,201 GPM
 1 - 400 HP, 4,200 GPM
 TOTAL = 13,811 GPM @ 301 TDH
 (130 PSI)
 ELEV = 633 FT
 MAX OPERATING PRESSURE = 105 PSI
 HGL = 876 FT

PUMP STA 6A
 WATER RIGHT - 25,650 GPM
 PUMP TAG RATINGS
 4 - 400 HP, 3,525 GPM
 1 - 450 HP, 3,886 GPM
 1 - 500 HP, 4,150 GPM
 1 - 500 HP, 4,501 GPM
 TOTAL = 26,637 GPM @ 370 TDH
 (160 PSI)
 OPERATING = 381 TDH (165 PSI)
 ELEV = 623 FT
 HGL = 1004 FT

PUMP STA 6B
 WATER RIGHT - 19,000 GPM
 PUMP TAG RATINGS
 2 - 450 HP, 4,902 GPM
 2 - 500 HP, 5,502 GPM
 TOTAL = 20,808 GPM @ 290 TDH
 (125 PSI)
 OPERATING = 231 TDH (100 PSI)
 ELEV = 623 FT
 HGL = 854 FT

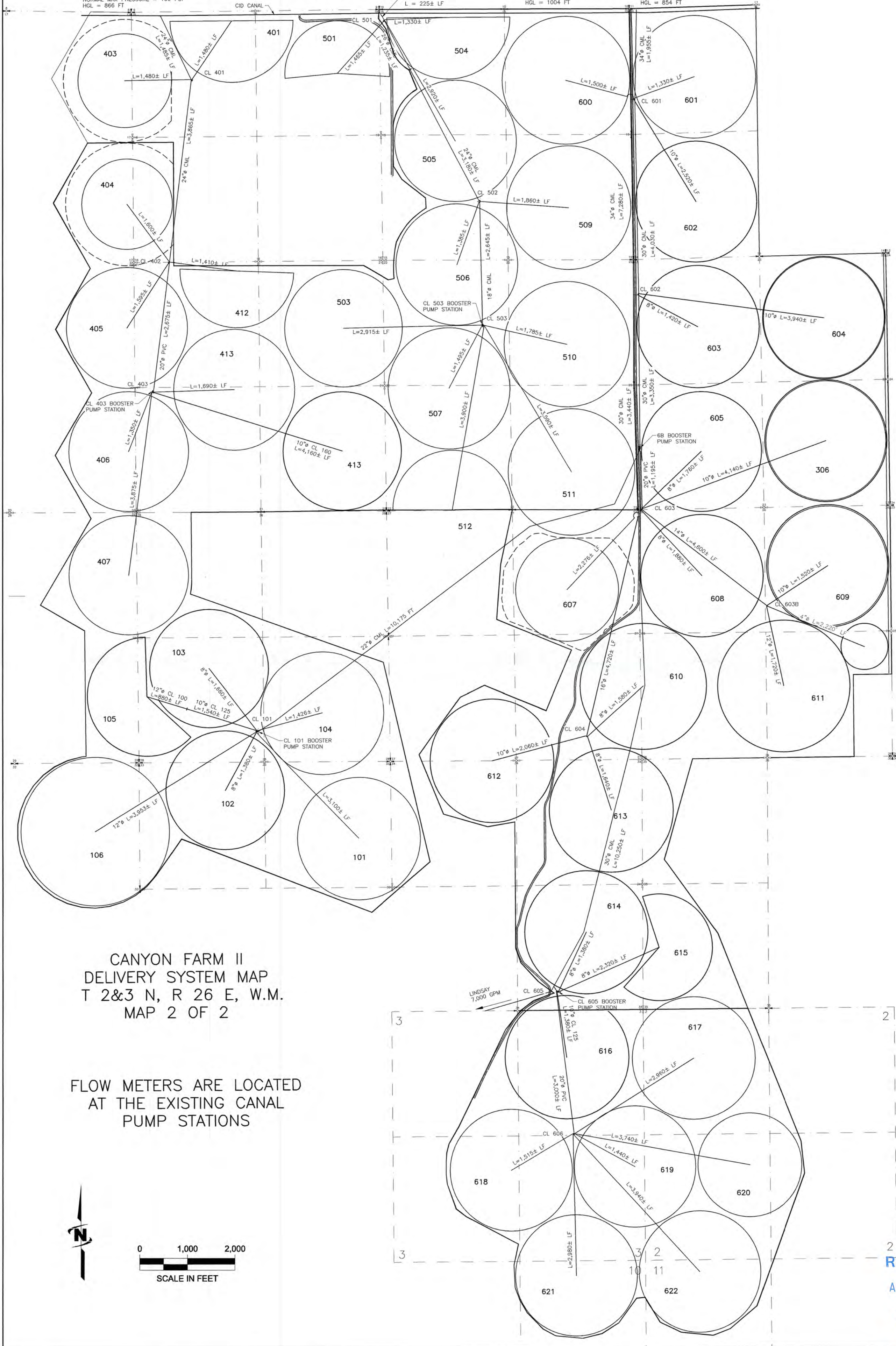

CANYON FARM II
 DELIVERY SYSTEM MAP
 T 2&3 N, R 26 E, W.M.
 MAP 2 OF 2

FLOW METERS ARE LOCATED
 AT THE EXISTING CANAL
 PUMP STATIONS

IRRIGATION WATER

RECEIVED
 AUG 17 2020
 OWRD

FLOW METER
LOCATED AT
COLUMBIA RIVER POD

CANYON FARM II
DELIVERY SYSTEM MAP
COLUMBIA RIVER WATER
T 2&3 N, R 26, 27 & 28
E, W.M.
MAP 1 OF 2

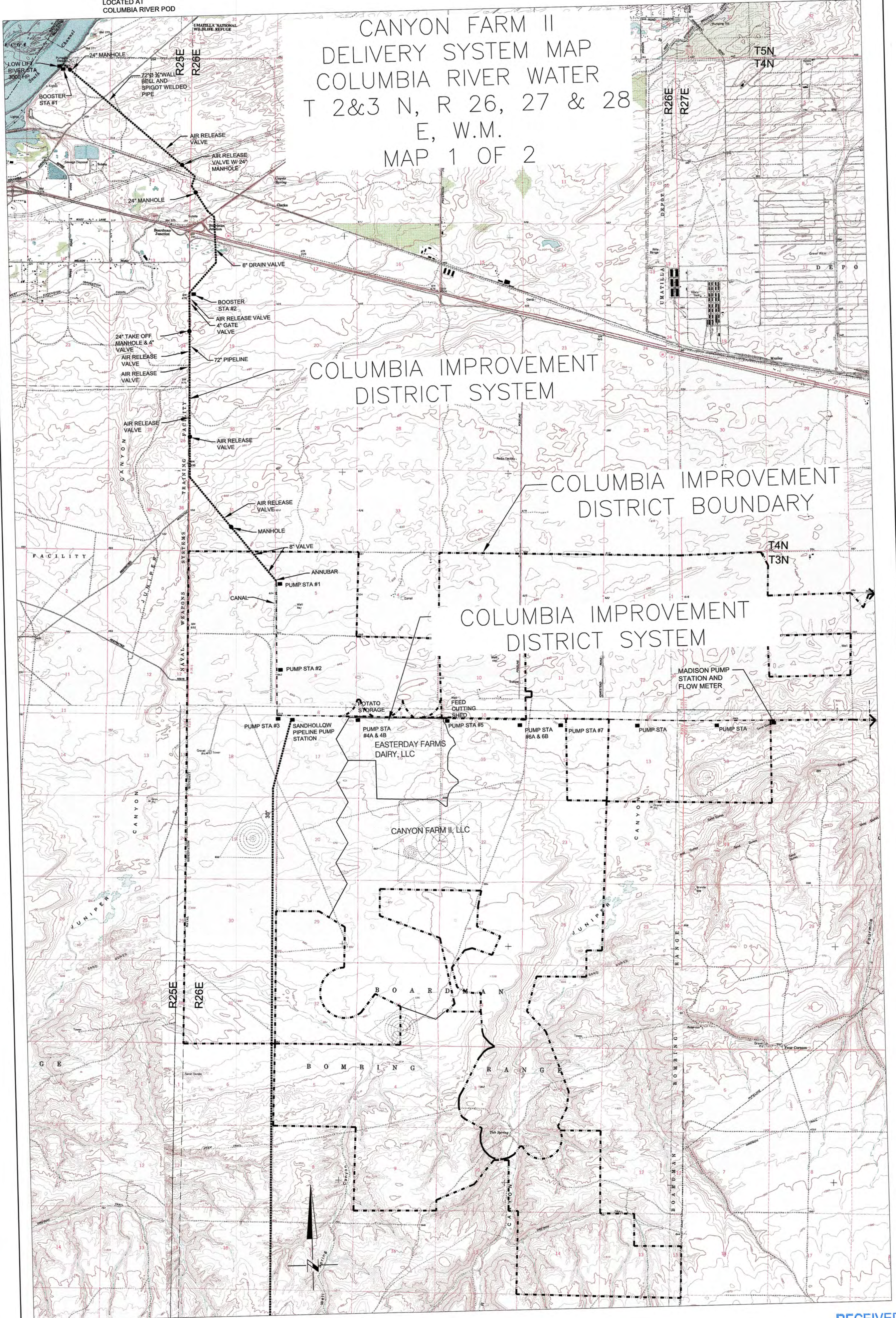

RECEIVED
AUG 17 2020
OWRD

CANYON FARM II, LLC CLAIM OF BENEFICIAL USE MAP FOR T-13266 FORMER CERT 80062 T3N R26EWM

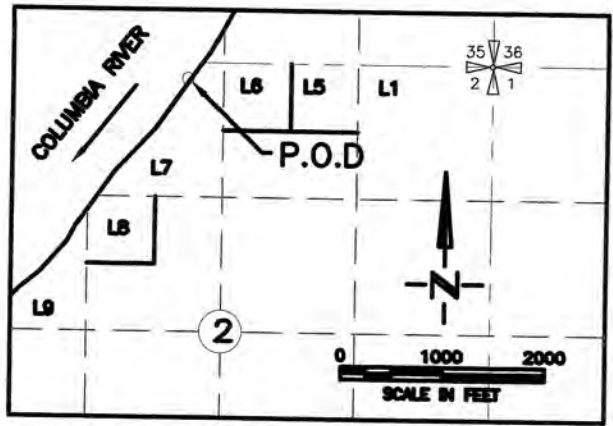
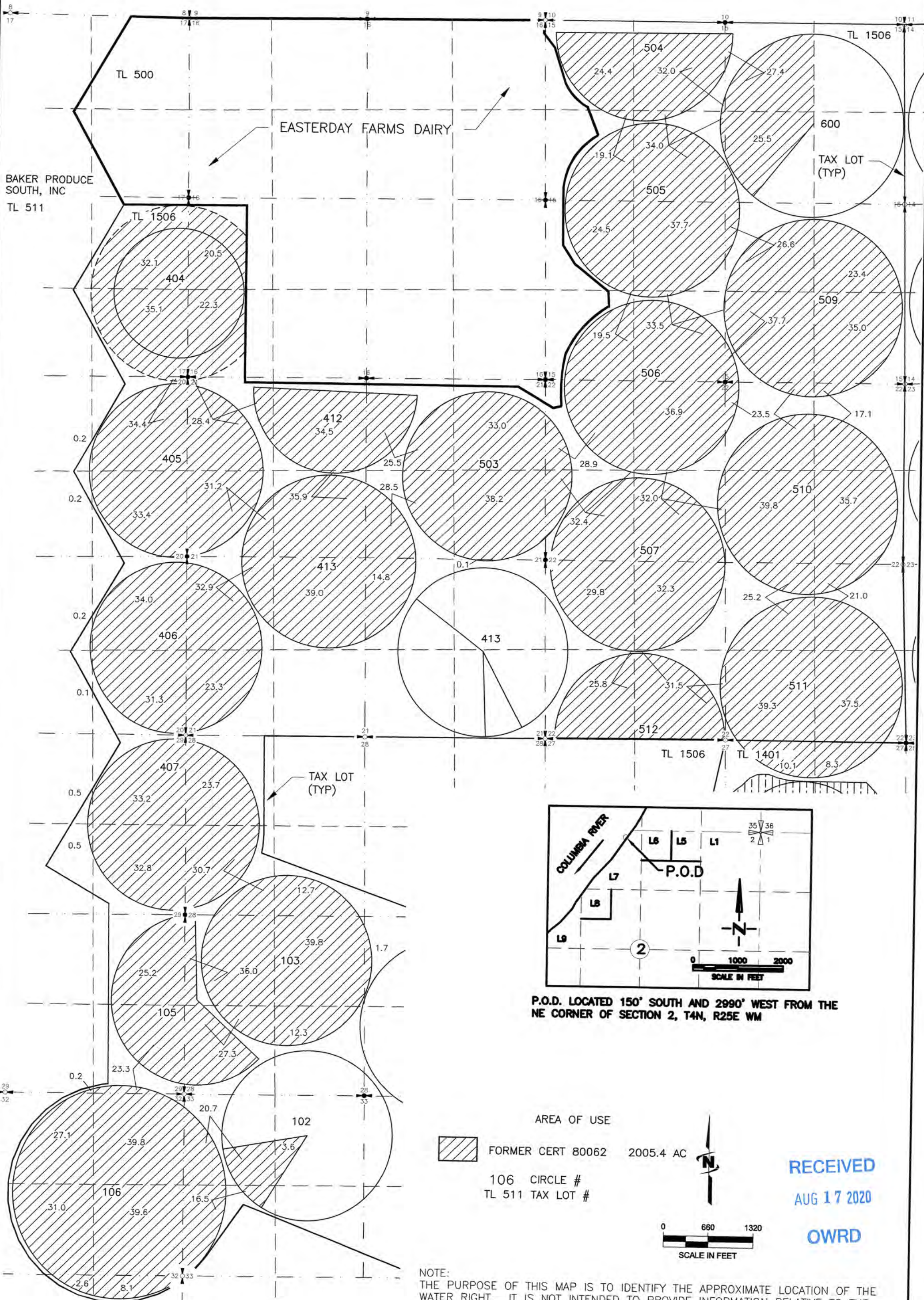

P.O.D. LOCATED 150' SOUTH AND 2990' WEST FROM THE NE CORNER OF SECTION 2, T4N, R25E WM

AREA OF USE
 FORMER CERT 80062 2005.4 AC
 106 CIRCLE #
 TL 511 TAX LOT #

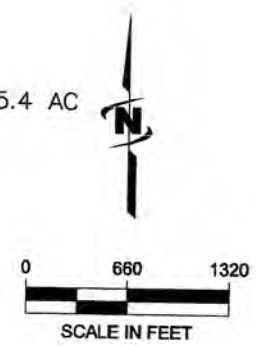

RECEIVED
AUG 17 2020
OWRD

NOTE:
 THE PURPOSE OF THIS MAP IS TO IDENTIFY THE APPROXIMATE LOCATION OF THE WATER RIGHT. IT IS NOT INTENDED TO PROVIDE INFORMATION RELATIVE TO THE LOCATION OF PROPERTY OWNERSHIP BOUNDARY LINES. PIPE LOCATIONS AND SIZES WHERE SHOWN WERE PROVIDED BY FARM OPERATIONAL PERSONNEL AND ARE APPROXIMATE LOCATIONS AND SIZES.

**CANYON FARM II, LLC CLAIM OF BENEFICIAL
USE MAP FOR T-13266,
FORMER CERT 86857
T3N R26EWM**

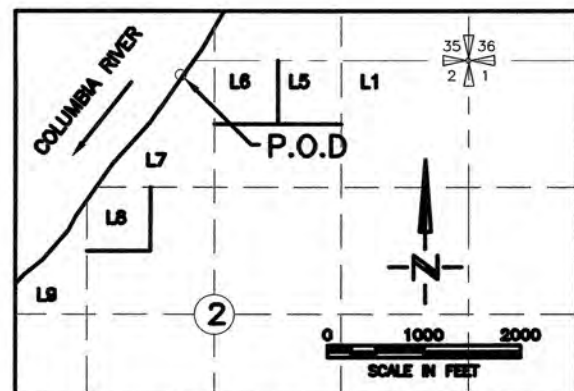
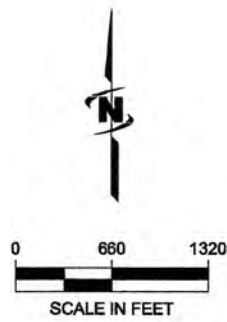
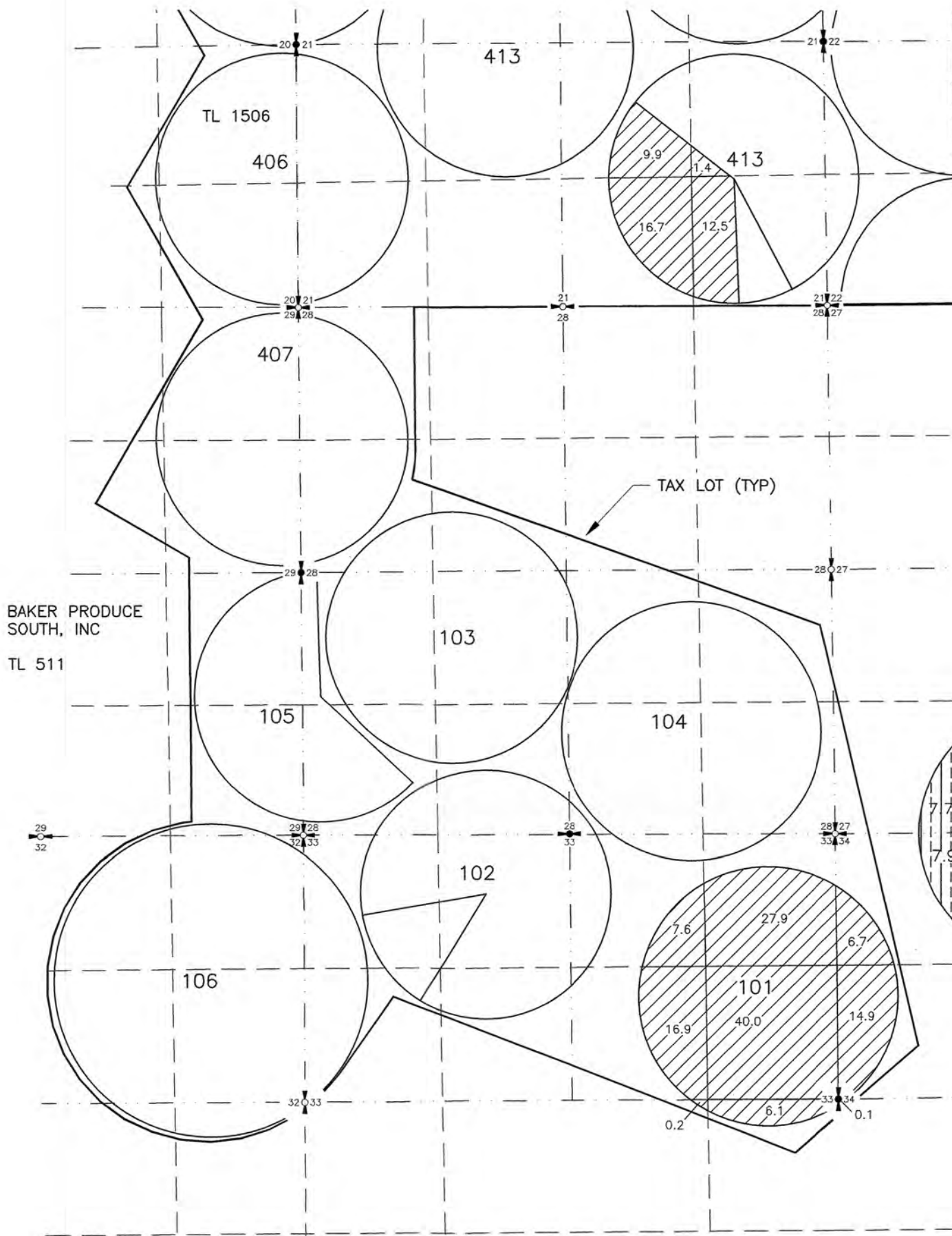

P.O.D. LOCATED 150' SOUTH AND 2990' WEST FROM THE NE CORNER OF SECTION 2, T4N, R25E WM

AREA OF USE

 CERT FORMER 86857 160.9 AC

106 CIRCLE #
TL 511 TAX LOT #

RECEIVED

AUG 17 2020

OWRD

NOTE:
THE PURPOSE OF THIS MAP IS TO IDENTIFY THE APPROXIMATE LOCATION OF THE WATER RIGHT. IT IS NOT INTENDED TO PROVIDE INFORMATION RELATIVE TO THE LOCATION OF PROPERTY OWNERSHIP BOUNDARY LINES. PIPE LOCATIONS AND SIZES WHERE SHOWN WERE PROVIDED BY FARM OPERATIONAL PERSONNEL AND ARE APPROXIMATE LOCATIONS AND SIZES.

**CANYON FARM II, LLC CLAIM OF BENEFICIAL USE
MAP FOR T-13266, FORMER CERT 86856
T3N R26EWM**

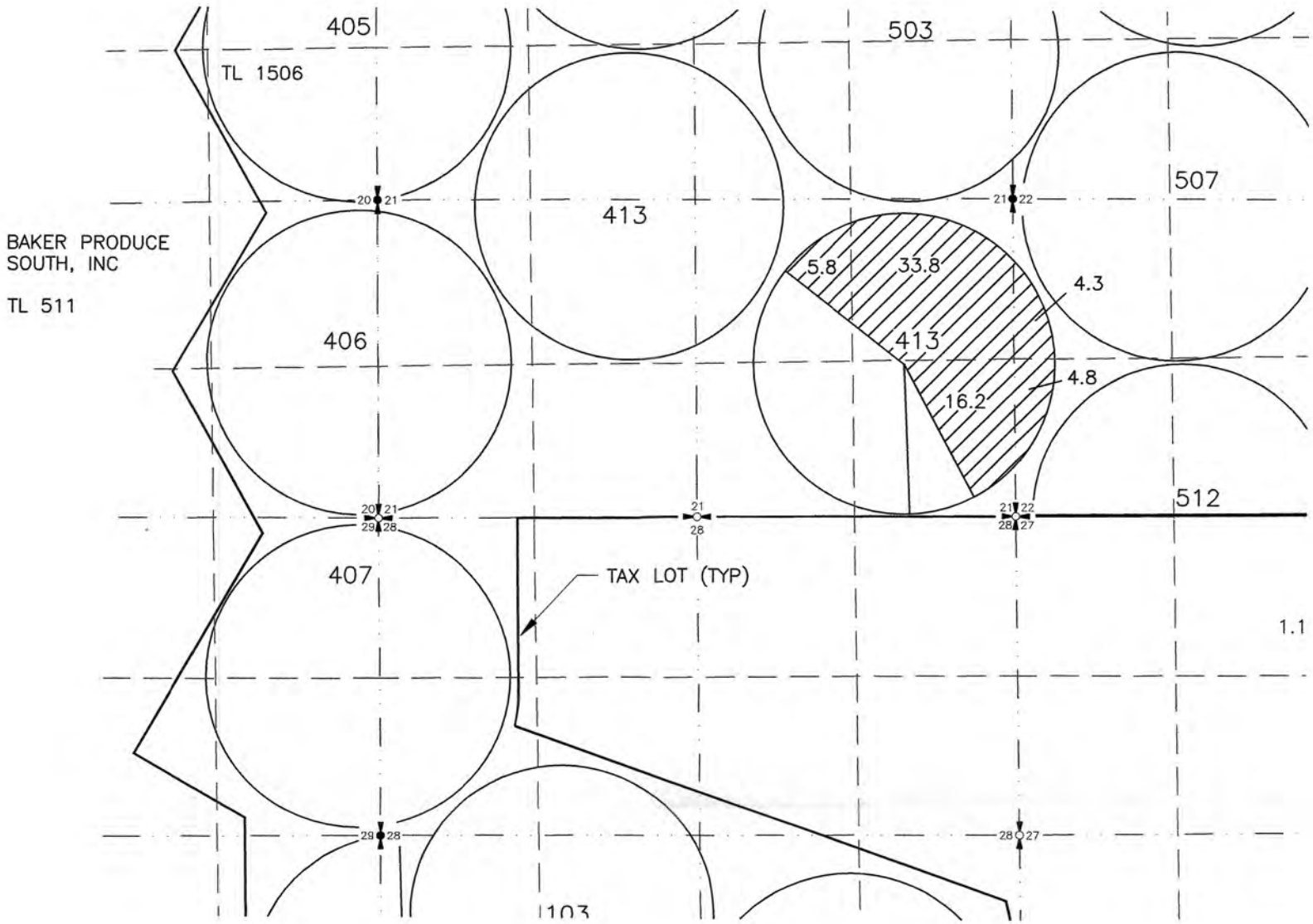

BAKER PRODUCE
SOUTH, INC
TL 511

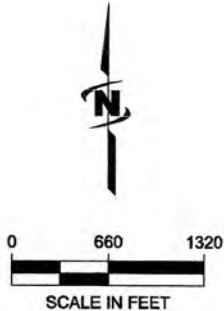

AREA OF USE

 CERT FORMER 86856 64.9 AC

106 CIRCLE #
TL 511 TAX LOT #

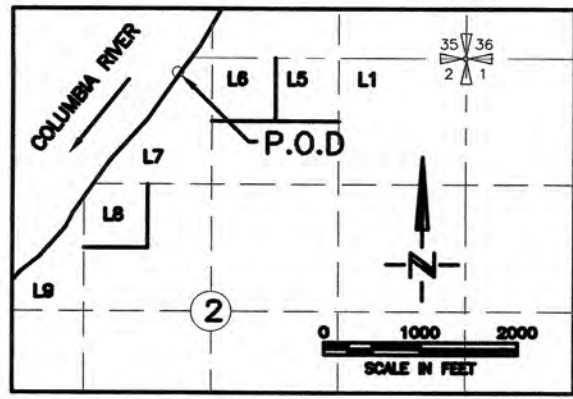

P.O.D. LOCATED 150' SOUTH AND 2990' WEST FROM THE NE CORNER OF SECTION 2, T4N, R25E WM

RECEIVED
AUG 17 2020
OWRD

THE PURPOSE OF THIS MAP IS TO IDENTIFY THE APPROXIMATE LOCATION OF THE WATER RIGHT. IT IS NOT INTENDED TO PROVIDE INFORMATION RELATIVE TO THE LOCATION OF PROPERTY OWNERSHIP BOUNDARY LINES. PIPE LOCATIONS AND SIZES WHERE SHOWN ARE PROVIDED BY FARM OPERATIONAL PERSONNEL AND ARE APPROXIMATE LOCATIONS AND SIZES.

**CANYON FARM II, LLC CLAIM OF BENEFICIAL USE
MAP FOR T-13266,
FORMER CERT 86993
T3N R26EWM**

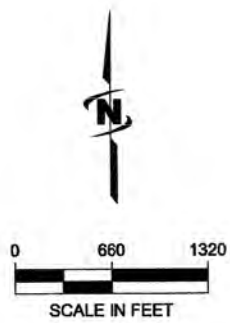
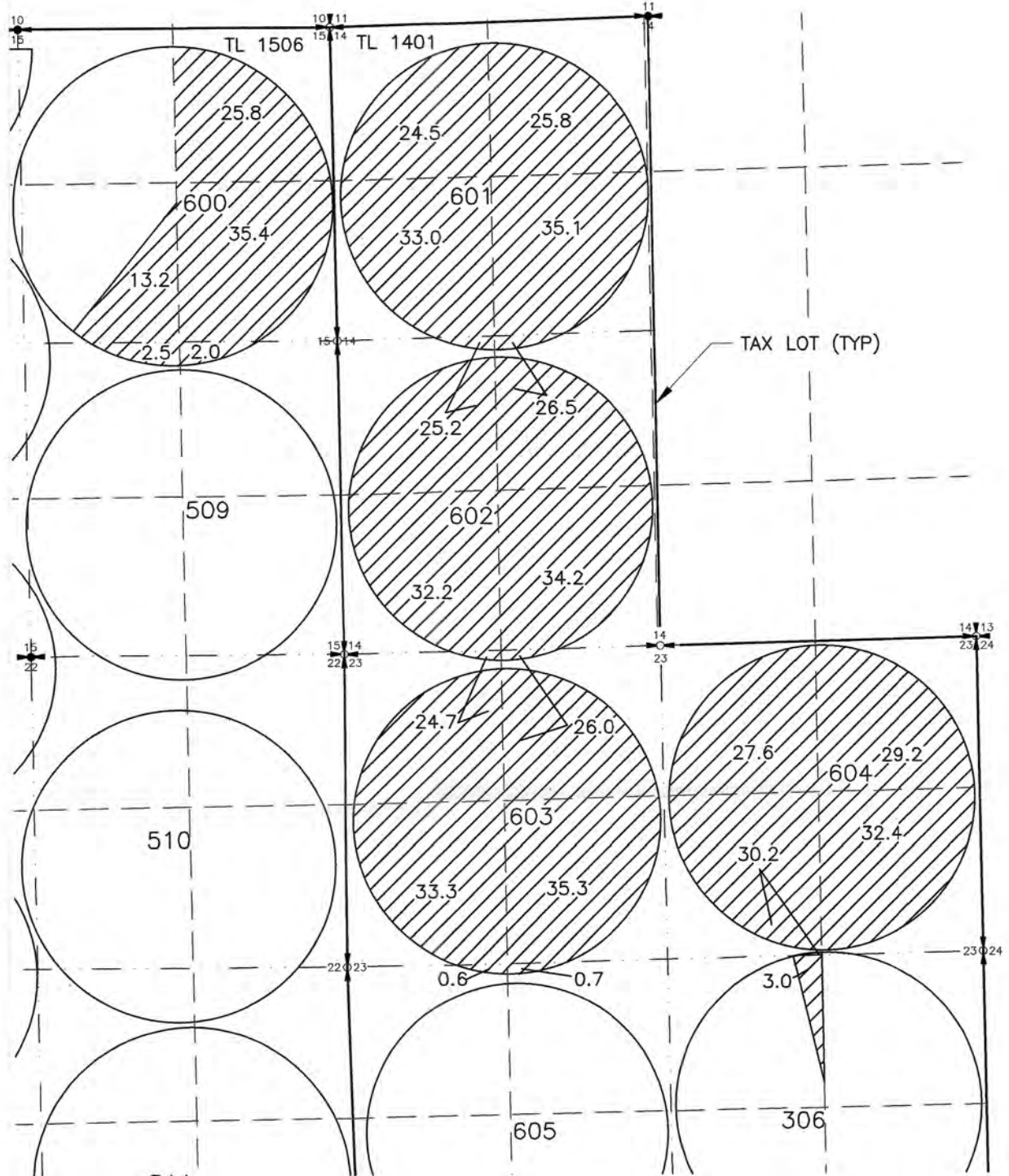

AREA OF USE

 CERT FORMER 86993 558.4 AC

106 CIRCLE #
TL 511 TAX LOT #

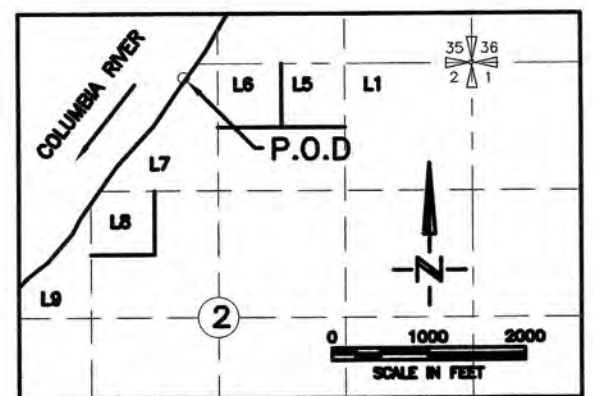

P.O.D. LOCATED 150' SOUTH AND 2990' WEST FROM THE NE CORNER OF SECTION 2, T4N, R25E WM

NOTE:
THE PURPOSE OF THIS MAP IS TO IDENTIFY THE APPROXIMATE LOCATION OF THE WATER RIGHT. IT IS NOT INTENDED TO PROVIDE INFORMATION RELATIVE TO THE LOCATION OF PROPERTY OWNERSHIP BOUNDARY LINES. PIPE LOCATIONS AND SIZES WHERE SHOWN WERE PROVIDED BY FARM OPERATIONAL PERSONNEL AND ARE APPROXIMATE LOCATIONS AND SIZES.

RECEIVED

AUG 17 2020

OWRD

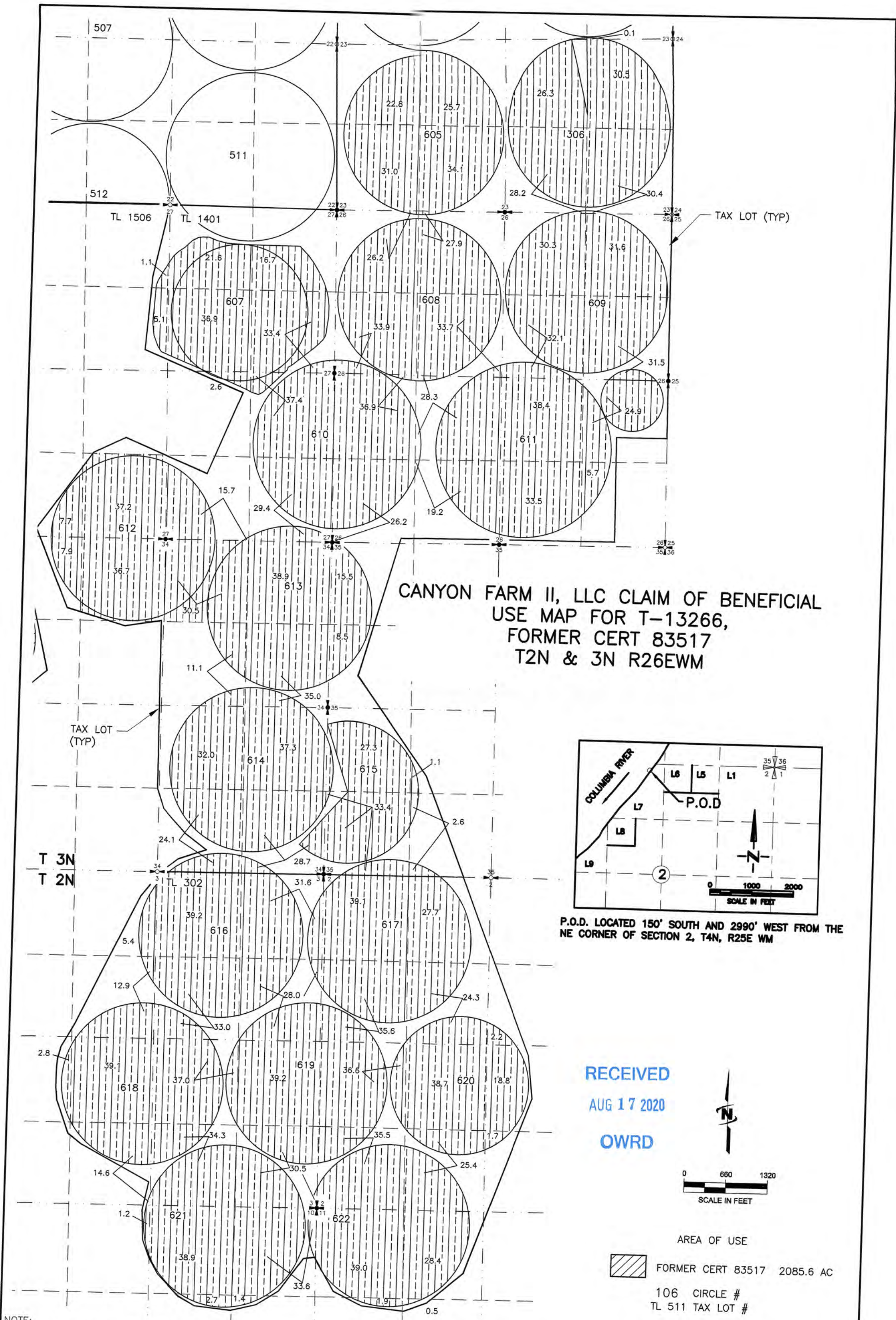

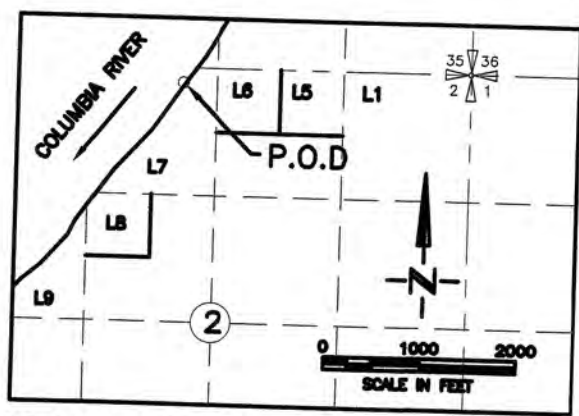

**CANYON FARM II, LLC CLAIM OF BENEFICIAL
USE MAP FOR T-13266,
FORMER CERT 83517
T2N & 3N R26EWM**

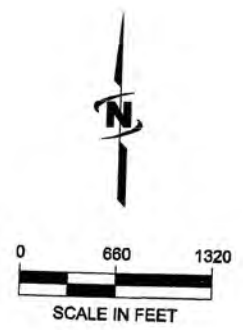

P.O.D. LOCATED 150' SOUTH AND 2990' WEST FROM THE NE CORNER OF SECTION 2, T4N, R25E WM

RECEIVED
AUG 17 2020
OWRD



AREA OF USE
 FORMER CERT 83517 2085.6 AC
 106 CIRCLE #
 TL 511 TAX LOT #

NOTE:
THE PURPOSE OF THIS MAP IS TO IDENTIFY THE APPROXIMATE LOCATION OF THE WATER RIGHT. IT IS NOT INTENDED TO PROVIDE INFORMATION RELATIVE TO THE LOCATION OF PROPERTY OWNERSHIP BOUNDARY LINES. PIPE LOCATIONS AND SIZES WHERE SHOWN WERE PROVIDED BY FARM OPERATIONAL PERSONNEL AND ARE APPROXIMATE LOCATIONS AND SIZES.

**CANYON FARM II, LLC CLAIM OF BENEFICIAL USE
MAP FOR T-13266, FORMER CERT 86856
T3N R26EWM**

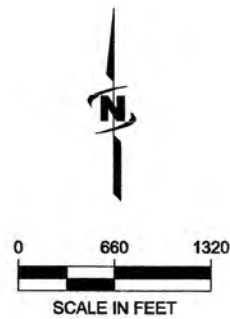
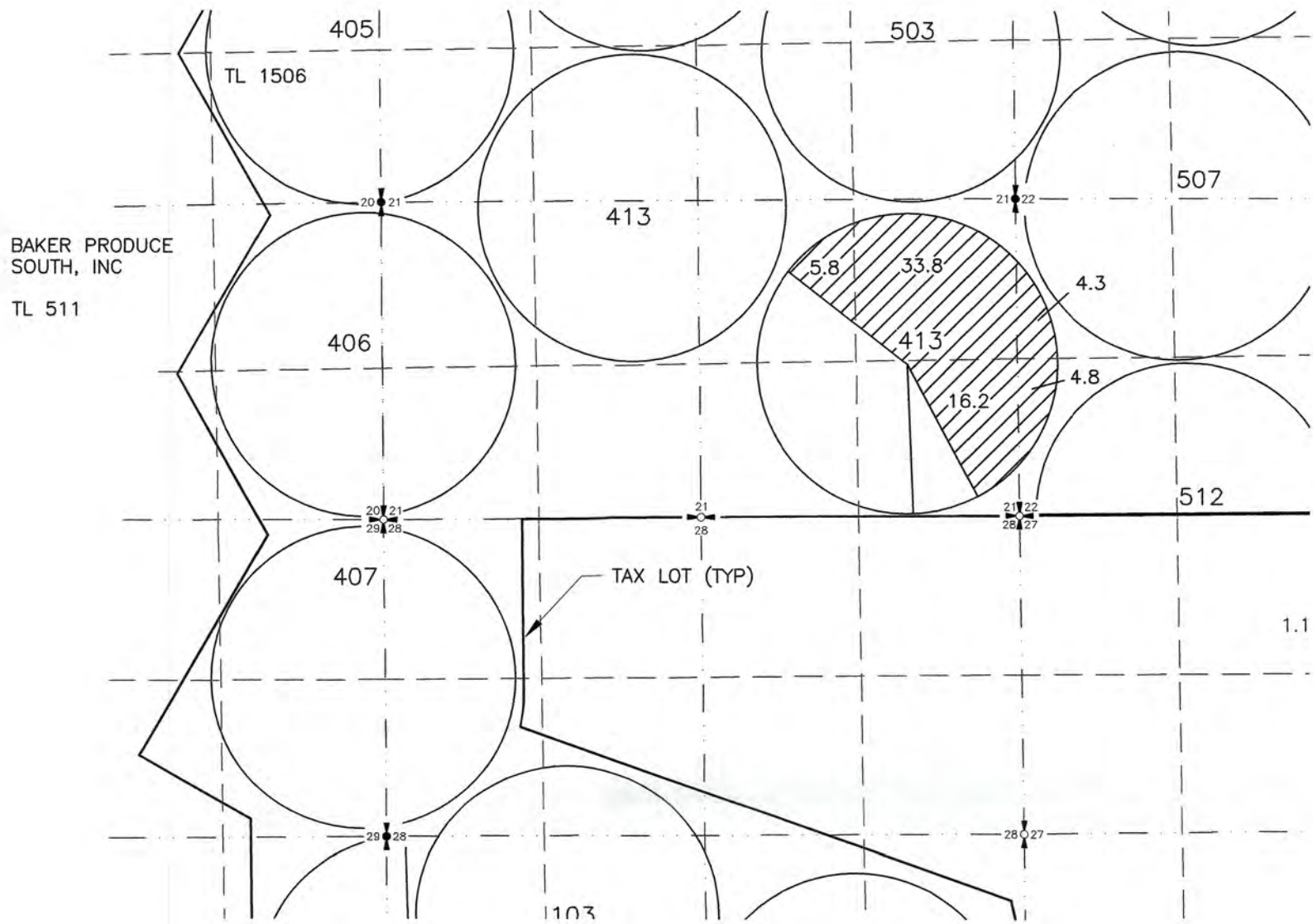

AREA OF USE

CERT FORMER 86856 64.9 AC

106 CIRCLE #
TL 511 TAX LOT #

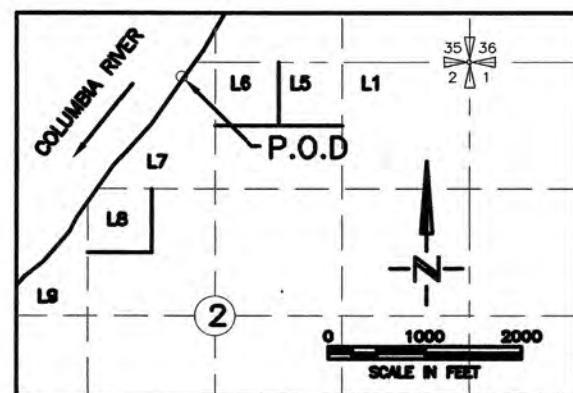



P.O.D. LOCATED 150' SOUTH AND 2990' WEST FROM THE NE CORNER OF SECTION 2, T4N, R25E WM

**RECEIVED
AUG 17 2020
OWRD**

NOTE:
THE PURPOSE OF THIS MAP IS TO IDENTIFY THE APPROXIMATE LOCATION OF THE WATER RIGHT. IT IS NOT INTENDED TO PROVIDE INFORMATION RELATIVE TO THE LOCATION OF PROPERTY OWNERSHIP BOUNDARY LINES. PIPE LOCATIONS AND SIZES WHERE SHOWN WERE PROVIDED BY FARM OPERATIONAL PERSONNEL AND ARE APPROXIMATE LOCATIONS AND SIZES.

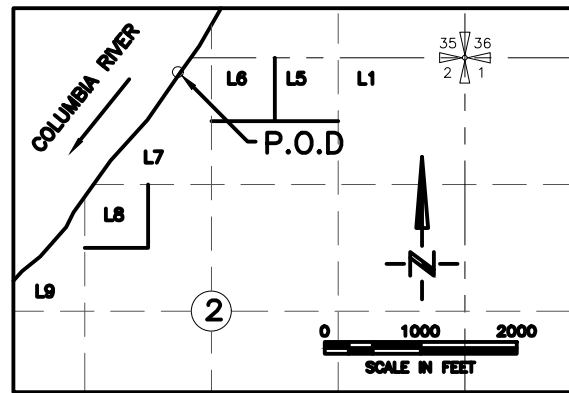
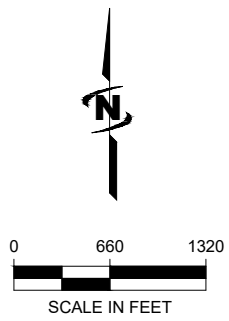
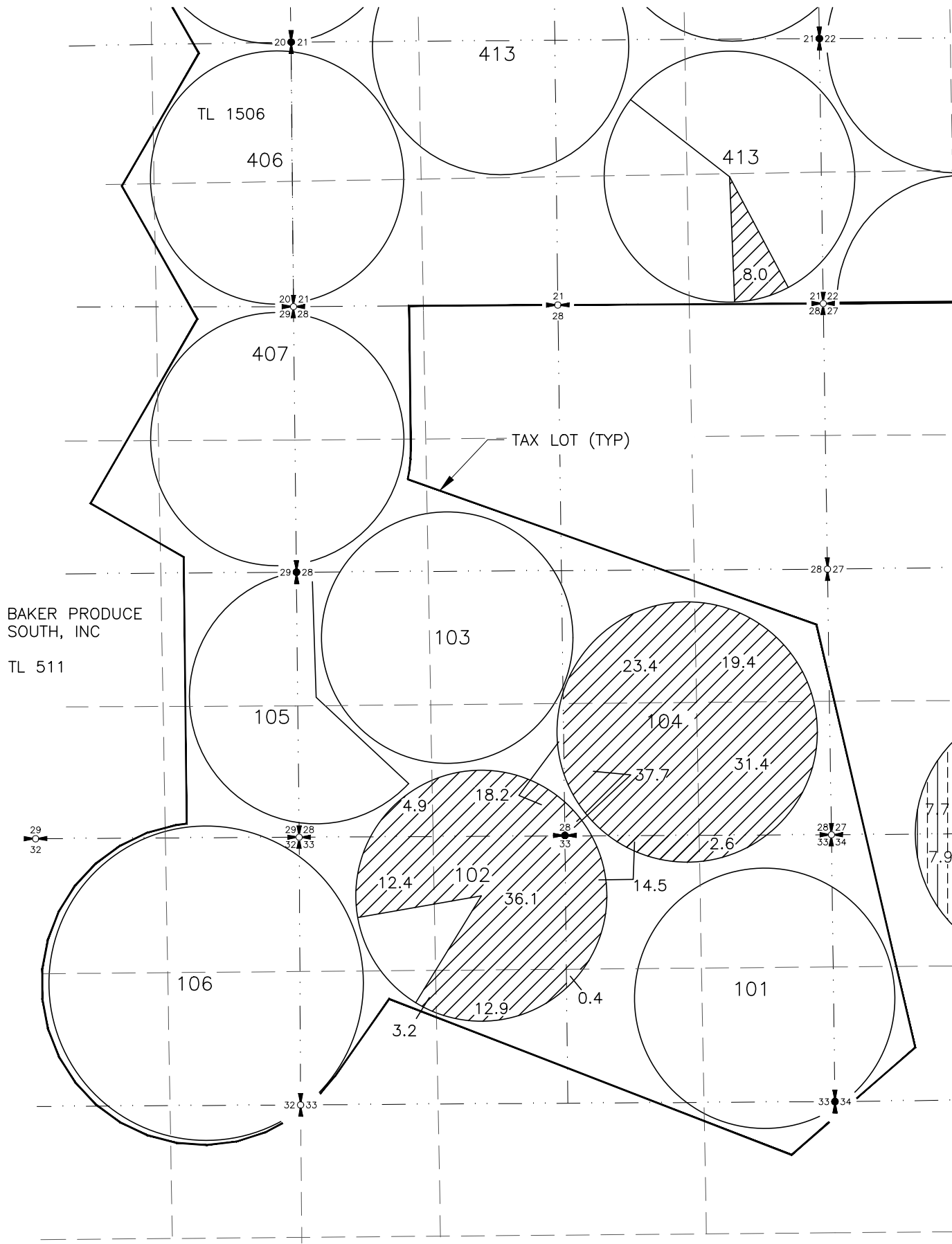
**CANYON FARM II, LLC CLAIM OF
BENEFICIAL USE MAP FOR T-13266,
FORMER CERT 86992
T3N R26EWM**



AREA OF USE
 CERT FORMERLY 86992 225.1 AC
 106 CIRCLE #
 TL 511 TAX LOT #

P.O.D. LOCATED 150' SOUTH AND 2990' WEST FROM THE NE CORNER OF SECTION 2, T4N, R25E WM

NOTE:
 THE PURPOSE OF THIS MAP IS TO IDENTIFY THE APPROXIMATE LOCATION OF THE WATER RIGHT. IT IS NOT INTENDED TO PROVIDE INFORMATION RELATIVE TO THE LOCATION OF PROPERTY OWNERSHIP BOUNDARY LINES. PIPE LOCATIONS AND SIZES WHERE SHOWN WERE PROVIDED BY FARM OPERATIONAL PERSONNEL AND ARE APPROXIMATE LOCATIONS AND SIZES.