



State of Oregon
Water Resources Department
725 Summer Street NE, Suite A
Salem, Oregon 97301-1266
(503) 986-0900

Application for Instream Lease Pooled Lease Form

A summary of review criteria and procedures that are generally applicable to these applications is available at www.wrd.state.or.us/OWRD/PUBS/forms.shtml.

Pursuant to ORS 537.348(2) and OAR 690-077

Optional Identification by Lessor/Lessee: IL-2009-03
Lease Application Number (assigned by WRD): IL-965

This Lease is between:

Lessor #2: Irrigation District or Other Water Purveyor

Name Central Oregon Irrigation District
Mailing address 1055 SW Lake Ct
City, State, Zip Code Redmond, OR 97756
Telephone number 541-504-7577
Email address lauraw@coid.org

The water right to be leased is located in Deschutes County.

Lessee (if different than Oregon Water Resources Department):

Name Deschutes River Conservancy
Mailing address PO Box 1560
City, State, Zip Code Bend, OR 97709
Telephone number 541-382-5186
Email address gen@deschutesriver.org

RECEIVED

FEB 27 2009

WATER RESOURCES DEPT
SALEM, OREGON

Trustee:

Oregon Water Resources Department
725 Summer Street NE, Suite A
Salem, OR 97301-1266
(503) 986-0900

~I~ Water Right Holder and Water Right Information

- 1.2 Lessor #2 is the (Check one):
 Official representative of Central Oregon Irrigation District, the irrigation district, which conveys water to the subject water rights.
 Another party with an interest in the subject water rights representing _____.
 Not applicable.

- 1.3 For the water right(s) being leased, list all water rights appurtenant to the same lands. Indicate if there are any supplemental or overlying rights.

Certificate No. 83571 & 76714

1.4 Are some or all of the lands being leased part of a Conservation Reserve Enhancement Program. Yes No

1.5 **Water Rights Proposed to be Leased Instream.**

The first right to be leased identified in Section 1.3 is further described as follows:

Certificate No.: 83571

Priority date: October 31, 1900 & December 2, 1907 Type of use: Irrig

Legal Season of Use: April 1 to November 1

If an irrigation right, total number of acres to be leased: 13.92

Total acre-feet of storage to be leased, if applicable: 0

Maximum rate associated with subject water rights (cfs) being leased:

Priority 10/31/1900: Season 1: 0.173, Season 2: 0.231, Season 3: 0.306

Priority 12/02/1907: Season 3: 0.122

If there is more than one rate associated with a water right, describe below:

Season 1 (cfs) _____ Time period: _____

Season 2 (cfs) _____ Time period: _____

Season 3 (cfs) _____ Time period: _____

Maximum duty associated with subject water rights (ac-ft): 137.35

Conditions or other limitations, if any: None

RECEIVED

FEB 27 2009

WATER RESOURCES DEPT
SALEM, OREGON

If you need to enter another leased right, please use the additional water rights form.

~II~ Instream Water Right Information

2.1 **Public use.** This lease will increase streamflows that will benefit:

- Conservation, maintenance and enhancement of aquatic and fish life, wildlife, and fish and wildlife habitat
- Pollution abatement
- Recreation and scenic attraction

2.2 **Instream use created by lease.** The instream use to be created is described as follows:

Deschutes River

Tributary to Columbia River in the Deschutes Basin.

Describe the point of diversion (POD) and any associated reach(es) of the instream use being created. If possible list the reach by river mile. If no reach is identified, and there is only one POD listed on the certificate, the lease will be processed to be protected at the POD. (If more than one POD is listed on the certificate, then the POD and any associated reach(es) must be identified): POD #1 to Lake Billy Chinook River mile 0, mouth of the Deschutes

Maximum volume in acre-feet: Priority 10/31/1900: 75.87

Rate in cfs: Priority 10/31/1900: Season 1: 0.096, Season 2: 0.128, Season 3: 0.236

(If more than one rate, describe the rate associated within each time period or instream reach.)

Rate in cfs: _____

Rate in cfs: _____

(Use the section below to indicate a more restrictive period of use than allowed by the water right.)

Conditions to prevent injury, if any:

None

The instream flow will be allocated on a daily average basis up to the described rate from _____ through _____.

Other (describe): _____

2.3 **Term of lease.** This lease shall terminate on October 26, 2009.

2.4 **Flow protection.** The Trustee will regulate use of water from the source, subject to prior appropriation and the agency enforcement guidance, to assure the water is delivered to the point of diversion, and through the reach past junior downstream users, so long as flow is sufficient to meet the demand under priority date of the new instream use (see Section 2.2). As part of regulation activities the watermaster or a designee has access to the point of diversion and place of use for the water rights involved in this lease. No party is required to continuously measure the flow of the waterway described in Section 2.2.

~III~ Other Information

3.1 **Accuracy.** The Undersigned Lessor(s) and Lessee(s) declare that, to the best of their knowledge and belief, the information contained in this application is true, correct and complete. If after the lease order is signed, any information is determined to be false, the lease order may be modified or terminated. The lease only exercises the water rights being leased, for the term of the lease. It shall not be construed to overcome any claim that the water right may otherwise be subject to forfeiture for nonuse pursuant to ORS 540.610 during the period of time prior to the execution of the lease.

3.2 **Lease.** Lessor(s) and Lessee(s) agree to lease the water rights listed in Section(s) 1.5 for instream use for the term of this lease through Lessee to the Trustee, the Oregon Water Resources Department, pursuant to the provisions of ORS 537.348(2) and OAR 690-077.

3.3 **Precedent.** If a right which has been leased is later proposed to be leased again or transferred to an instream use under ORS 537.348 and OAR 690-077 a new injury review shall be required, and a prior short term lease shall not set a precedent for the amount of water to be leased or transferred instream.

3.4 **Suspension of original use.** During the period of the lease, the water right holder agrees to suspend use of water allowed under the subject water rights and under any water right that is supplemental to the subject water rights.

3.5 **Termination provision.**

For multiyear leases, the Lessor(s) shall have the option of terminating the lease each year with written notice to the Department. The lease may be terminated at any time during the calendar year. However, if the termination request is received less than 30-days prior to the period of allowed instream use or after the period of allowed use has begun for the water right(s) being leased, water may not be used under the right(s) leased until the following calendar year, unless the Director determines that enlargement would not occur. The Department may also require:

- Written notice to the Department with original signatures;
- Consent by all parties to the lease; and/or
- Written notice to the Watermaster's office.

For multiyear leases, the lessor shall not have the option of terminating the lease, without consent by all parties to the lease.

RECEIVED

FEB 27 2009

3.6 Modification to prevent injury. Allocation of water to the instream use described in Section 2.2 during the term of this lease is not reasonably expected to cause injury to other rights to use water from the same source. If injury is found after this lease is signed, the lease may be modified or terminated to prevent injury.

3.7 Fees. Pursuant to ORS 536.050, the following fee is included:

- \$200 for an application with four or more landowners or four or more water rights.
- \$100 for all other applications.

Lessor #2: *Shirley J. Williams* Date: 02/17/2009
Central Oregon Irrigation District

Lessee: *[Signature]* Date: 02/25/09
Deschutes River Conservancy

Other Attachments as Needed:

- Attachment 1: Tax Lot Map. (See instructions.)
- Attachment 2: Detailed map illustrating lands under subject rights to be leased; required if only part of a right is being leased instream. (See instructions.)
- Attachment 3: Supporting documentation indicating why a right is valid and not subject to forfeiture even though the right has not been exercised for five or more consecutive years (required if the second box in Section 1.6 is checked).
- Attachment 4: Split Season Instream Use Form
- Attachment 5: Pooled Lease Water Right Holder Form

RECEIVED

FEB 27 2009

WATER RESOURCES DEPT
SALEM, OREGON

**Central Oregon Irrigation District
IL-2009-03
Water Right changes for Instream Maps**

TRS	QQ	AC	OWRD #
18-13-11	SE NE	0.35 ac Trans off	T-10754

RECEIVED

FEB 27 2009

WATER RESOURCES DEPT
SALEM, OREGON



State of Oregon
Water Resources Department
725 Summer Street NE, Suite A
Salem, Oregon 97301-1266
(503) 986-0900

Application for Instream Lease

Attachment 5: Pooled Water Right Holder Form

A summary of review criteria and procedures that are generally applicable to these applications is available at www.wrd.state.or.us/OWRD/PUBS/forms.shtml.

Pursuant to ORS 537.348(2) and OAR 690-077

Optional Identification by Lessor/Lessee: 2864
Lease Application Number (assigned by WRD): IL-965

This Lease is with:

Lessor #1 (Water Right Holder):

Name Craig & Kristina Glazier
Mailing address 773 SE Briarwood Ct
City, State, Zip Code Bend, OR 97702
Telephone number ~~541-647-0924~~ 541-647-0924
Email address craig@havglaz.com

RECEIVED

FEB 27 2009

WATER RESOURCES DEPT
SALEM, OREGON

If additional water right holders, enter water right holder information below

Note: The section numbering associated with this form corresponds to that found on the "Standard Instream Lease Application" form. The "Pooled Lease" form and "Pooled Water Right Holder" form(s) are used to provide the same information as the "Standard Instream Lease Application" form. Consequently, the numbering on this form is not always sequential.

~I~ Water Right Holder and Water Right Information

1.1 Lessor #1 is the water right holder, or authorized agent for property described in Section 1.5. If the water right appurtenant to these lands is also appurtenant to lands owned by others who are not included in this application, then Attachment 1 (tax lot map), needs to be included.

1.3 For the water right(s) being leased, list all water rights appurtenant to the same lands. Indicate if there are any supplemental or overlying rights.

Certificate No. 83571 & 76714

1.4 Are some or all of the lands being leased part of a Conservation Reserve Enhancement Program. Yes No

1.5 **Water Right(s) Proposed to be Leased Instream.** Water right holder proposes to lease the water rights shown on the map attached as Exhibit 5-B and described as follows:
[This information may be included on Exhibit 5-A, or an additional map may be attached. Crosshatch the area of water rights being leased. Attached map(s) must identify water right holder, township, range, section and 1/4 1/4, tax lot number, map orientation and scale.]

T	R	Sect	1/4	Tax Lot	Acres	Type of Use	Certificate #	Page(s) #	Priority *	
*(Identify pertinent page number of certificate, if certificate is greater than 10 pages; identify priority date if there is more than one per certificate)										
1.	17 S	13 E	21	NW SE	1400	0.27	Irrigation	83571	47	10/31/1900
2.	17 S	13 E	21	NW SE	1401	1.60	Irrigation	83571	47	10/31/1900
3.	17 S	13 E	21	NW SE	1402	0.20	Irrigation	83571	47	10/31/1900
4.	17 S	13 E	21	NW SE	1403	1.40	Irrigation	83571	47	10/31/1900
5.										

Total number of acres, if for irrigation, by certificate and priority date: Cert #83571, Oct. 31, 1900 - 3.47 acres (Since HB 3111, there has been a tax lot split of original TL 1400, creating TL's 1400, 1401, 1402, and 1403. The water rights remained as mapped.)

Conditions or other limitations, if any: None

If you need to enter another leased right, please use the Additional Water Right Form for Pooled Water Right Holder.

1.6 Validity of rights. Lessor(s) attests (mark one) that:

- The water has been used over the past five years according to the terms and conditions of the water right certificate or as an instream water right or
- The water has not been used over the past five years according to the terms and conditions of the water right certificate, however the water right is not subject to forfeiture under ORS 540.610(2)()(include necessary supporting documents in Attachment 3).

RECEIVED

FEB 27 2009

~II~ Instream Water Right Information

WATER RESOURCES DEPT
SALEM, OREGON

2.3 Term of lease. This lease shall terminate on October 31, 2009. (If there is a conflict between the Pooled Lease Form and this form, the Pooled Lease Form will be the official term of the lease.)

~III~ Other Information

3.1 Accuracy. The Undersigned Lessor(s) and Lessee(s) declare that, to the best of their knowledge and belief, the information contained in this application is true, correct and complete. If after the lease order is signed, any information is determined to be false, the lease order may be modified or terminated. The lease only exercises the water rights being leased, for the term of the lease. It shall not be construed to overcome any claim that the water right may otherwise be subject to forfeiture for nonuse pursuant to ORS 540.610 during the period of time prior to the execution of the lease.

3.2 Lease. Lessor(s) and Lessee(s) agree to lease the water rights listed in Section(s) 1.5 for instream use for the term of this lease through Lessee to the Trustee, the Oregon Water Resources Department, pursuant to the provisions of ORS 537.348(2) and OAR 690-077.

3.3 Precedent. If a right which has been leased is later proposed to be leased again or transferred to an instream use under ORS 537.348 and OAR 690-077 a new injury review shall be required, and a prior short term lease shall not set a precedent for the amount of water to be leased or transferred instream.

3.4 Suspension of original use. During the period of the lease, the water right holder agrees to suspend use of water allowed under the subject water rights and under any water right that is supplemental to the subject water rights.

3.5 Termination provision.

- For multiyear leases, the Lessor(s) shall have the option of terminating the lease each year with written notice to the Department. The lease may be terminated at any time during the calendar year. However, if the termination request is received less than 30-days prior to the period of allowed instream use or after the period of allowed use has begun for the water right(s) being leased, water may not be used under the right(s) leased until the following calendar year, unless the Director determines that enlargement would not occur. The Department may also require:
 - Written notice to the Department with original signatures;
 - Consent by all parties to the lease; and/or
 - Written notice to the Watermaster's office.
- For multiyear leases, the lessor shall not have the option of terminating the lease, without consent by all parties to the lease.

3.6 Modification to prevent injury. Allocation of water to the instream use described in Section 2.2 during the term of this lease is not reasonably expected to cause injury to other rights to use water from the same source. If injury is found after this lease is signed, the lease may be modified or terminated to prevent injury.

Lessor #1: _____

Craig Glazier

Date: _____

2/6/09

Kristina Glazier

Date: _____

2/6/09

For additional Lessors, type in space for signature and date

RECEIVED

FEB 27 2009

WATER RESOURCES DEPT
SALEM, OREGON

Other Attachments As Needed:

Exhibit 5-A: Tax Lot Map. (See instructions.)

Exhibit 5-B: Detailed map illustrating lands under subject rights to be leased; required if only part of a right is being leased instream. Exhibits 5-A and 5-B may be combined into a single map. (See instructions.)

Exhibit 5-C: Supporting documentation indicating why a right is valid and not subject to forfeiture even though the right has not been exercised for five or more consecutive years (required if the second box in Section 1.6 of this form is checked)

Exhibit 5-D: Split Season Instream Use Form

**DESCHUTES COUNTY
SEC.21 T17S. R13E. W.M.**

SCALE - 1" = 400'



NW 1/4 OF THE SE 1/4

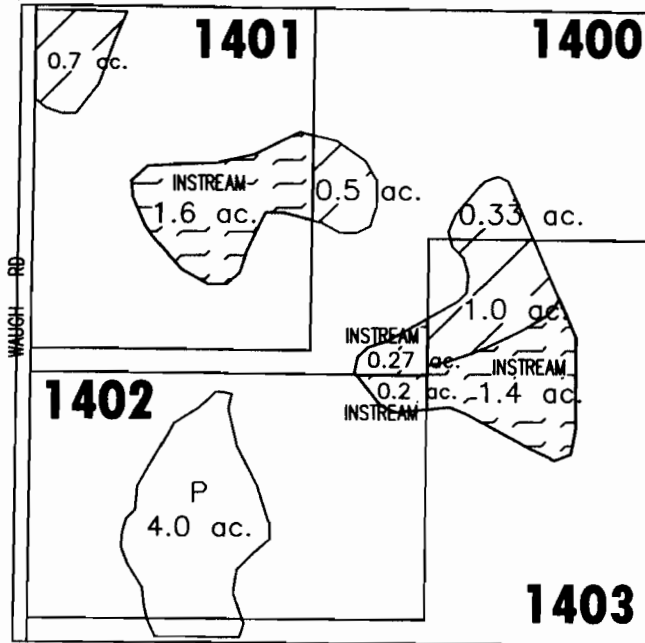

C 1/4 COR



RECEIVED

FEB 27 2009

WATER RESOURCES DEPT
SALEM, OREGON

-  'INSTREAM' LANDS
-  EXISTING WATER RIGHTS



APPLICATION FOR 1 YR INSTREAM LEASE

NAME: CRAIG & KRISTINA GLAZIER

TAXLOT #: 1400, 1401, 1402, 1403 3.47 ACRES INSTREAM

DATE: 02-03-09

FILE NO: E:\TRANSFER\INSTREAM\INSTRM09\1YR\171321_NWSE



State of Oregon
Water Resources Department
725 Summer Street NE, Suite A
Salem, Oregon 97301-1266
(503) 986-0900

Application for Instream Lease

Attachment 5: Pooled Water Right Holder Form

A summary of review criteria and procedures that are generally applicable to these applications is available at www.wrd.state.or.us/OWRD/PUBS/forms.shtml.

Pursuant to ORS 537.348(2) and OAR 690-077

Optional Identification by Lessor/Lessee: 2124
Lease Application Number (assigned by WRD): IL-965

This Lease is with:

Lessor #1 (Water Right Holder):

Name Melvin & Betty Johnson
Mailing address 62875 Schmidt Rd
City, State, Zip Code Bend, OR 97701
Telephone number 541-617-6139
Email address _____

RECEIVED

FEB 27 2009

WATER RESOURCES DEPT
SALEM, OREGON

If additional water right holders, enter water right holder information below

Note: The section numbering associated with this form corresponds to that found on the "Standard Instream Lease Application" form. The "Pooled Lease" form and "Pooled Water Right Holder" form(s) are used to provide the same information as the "Standard Instream Lease Application" form. Consequently, the numbering on this form is not always sequential.

~I~ Water Right Holder and Water Right Information

1.1 Lessor #1 is the water right holder, or authorized agent for property described in Section 1.5. If the water right appurtenant to these lands is also appurtenant to lands owned by others who are not included in this application, then Attachment 1 (tax lot map), needs to be included.

1.3 For the water right(s) being leased, list all water rights appurtenant to the same lands. Indicate if there are any supplemental or overlying rights.

Certificate No. 83571 & 76714

1.4 Are some or all of the lands being leased part of a Conservation Reserve Enhancement Program. Yes No

1.5 Water Right(s) Proposed to be Leased Instream. Water right holder proposes to lease the water rights shown on the map attached as Exhibit 5-B and described as follows:
[This information may be included on Exhibit 5-A, or an additional map may be attached. Crosshatch the area of water rights being leased. Attached map(s) must identify water right holder, township, range, section and 1/4 1/4, tax lot number, map orientation and scale.]

T	R	Sect	¼¼	Tax Lot	Acres	Type of Use	Certificate #	Page(s) #	Priority*	
*(Identify pertinent page number of certificate, if certificate is greater than 10 pages; identify priority date if there is more than one per certificate)										
1.	17 S	14 E	23	SE SE	1102	0.70	Irrigation	83571	51	10/31/1900
2.	17 S	14 E	24	SW SW	1501	0.08	Irrigation	83571	51	10/31/1900
3.										
4.										
5.										

Total number of acres, if for irrigation, by certificate and priority date: Cert #83571, Oct. 31, 1900 - 0.78 acres

Conditions or other limitations, if any: None

If you need to enter another leased right, please use the Additional Water Right Form for Pooled Water Right Holder.

1.6 Validity of rights. Lessor(s) attests (mark one) that:

- The water has been used over the past five years according to the terms and conditions of the water right certificate or as an instream water right or
- The water has not been used over the past five years according to the terms and conditions of the water right certificate, however the water right is not subject to forfeiture under ORS 540.610(2)()(include necessary supporting documentation as Attachment 3).

RECEIVED

FEB 27 2009

WATER RESOURCES DEPT
SALEM, OREGON

~II~ Instream Water Right Information

2.3 Term of lease. This lease shall terminate on October 31, 2009. (If there is a conflict between the Pooled Lease Form and this form, the Pooled Lease Form will be the official term of the lease.)

~III~ Other Information

- 3.1 Accuracy.** The Undersigned Lessor(s) and Lessee(s) declare that, to the best of their knowledge and belief, the information contained in this application is true, correct and complete. If after the lease order is signed, any information is determined to be false, the lease order may be modified or terminated. The lease only exercises the water rights being leased, for the term of the lease. It shall not be construed to overcome any claim that the water right may otherwise be subject to forfeiture for nonuse pursuant to ORS 540.610 during the period of time prior to the execution of the lease.
- 3.2 Lease.** Lessor(s) and Lessee(s) agree to lease the water rights listed in Section(s) 1.5 for instream use for the term of this lease through Lessee to the Trustee, the Oregon Water Resources Department, pursuant to the provisions of ORS 537.348(2) and OAR 690-077.
- 3.3 Precedent.** If a right which has been leased is later proposed to be leased again or transferred to an instream use under ORS 537.348 and OAR 690-077 a new injury review

shall be required, and a prior short term lease shall not set a precedent for the amount of water to be leased or transferred instream.

3.4 Suspension of original use. During the period of the lease, the water right holder agrees to suspend use of water allowed under the subject water rights and under any water right that is supplemental to the subject water rights.

3.5 Termination provision.

For multiyear leases, the Lessor(s) shall have the option of terminating the lease each year with written notice to the Department. The lease may be terminated at any time during the calendar year. However, if the termination request is received less than 30-days prior to the period of allowed instream use or after the period of allowed use has begun for the water right(s) being leased, water may not be used under the right(s) leased until the following calendar year, unless the Director determines that enlargement would not occur. The Department may also require:

- Written notice to the Department with original signatures;
- Consent by all parties to the lease; and/or
- Written notice to the Watermaster's office.

For multiyear leases, the lessor shall not have the option of terminating the lease, without consent by all parties to the lease.

3.6 Modification to prevent injury. Allocation of water to the instream use described in Section 2.2 during the term of this lease is not reasonably expected to cause injury to other rights to use water from the same source. If injury is found after this lease is signed, the lease may be modified or terminated to prevent injury.

Lessor #1: Melvin Johnson Date: 2-2-09
Melvin Johnson

Betty Johnson Date: 2-2-09
Betty Johnson

For additional Lessors, type in space for signature and date

RECEIVED

FEB 27 2009

WATER RESOURCES DEPT
SALEM, OREGON

Other Attachments As Needed:

- Exhibit 5-A: Tax Lot Map. (See instructions.)
- Exhibit 5-B: Detailed map illustrating lands under subject rights to be leased; required if only part of a right is being leased instream. Exhibits 5-A and 5-B may be combined into a single map. (See instructions.)
- Exhibit 5-C: Supporting documentation indicating why a right is valid and not subject to forfeiture even though the right has not been exercised for five or more consecutive years (required if the second box in Section 1.6 of this form is checked)
- Exhibit 5-D: Split Season Instream Use Form

**DESCHUTES COUNTY
SEC. 23, 24 T17S. R14E. W.M.**

SCALE - 1" = 400'



SE 1/4 OF THE SE 1/4; SW 1/4 OF THE SW 1/4

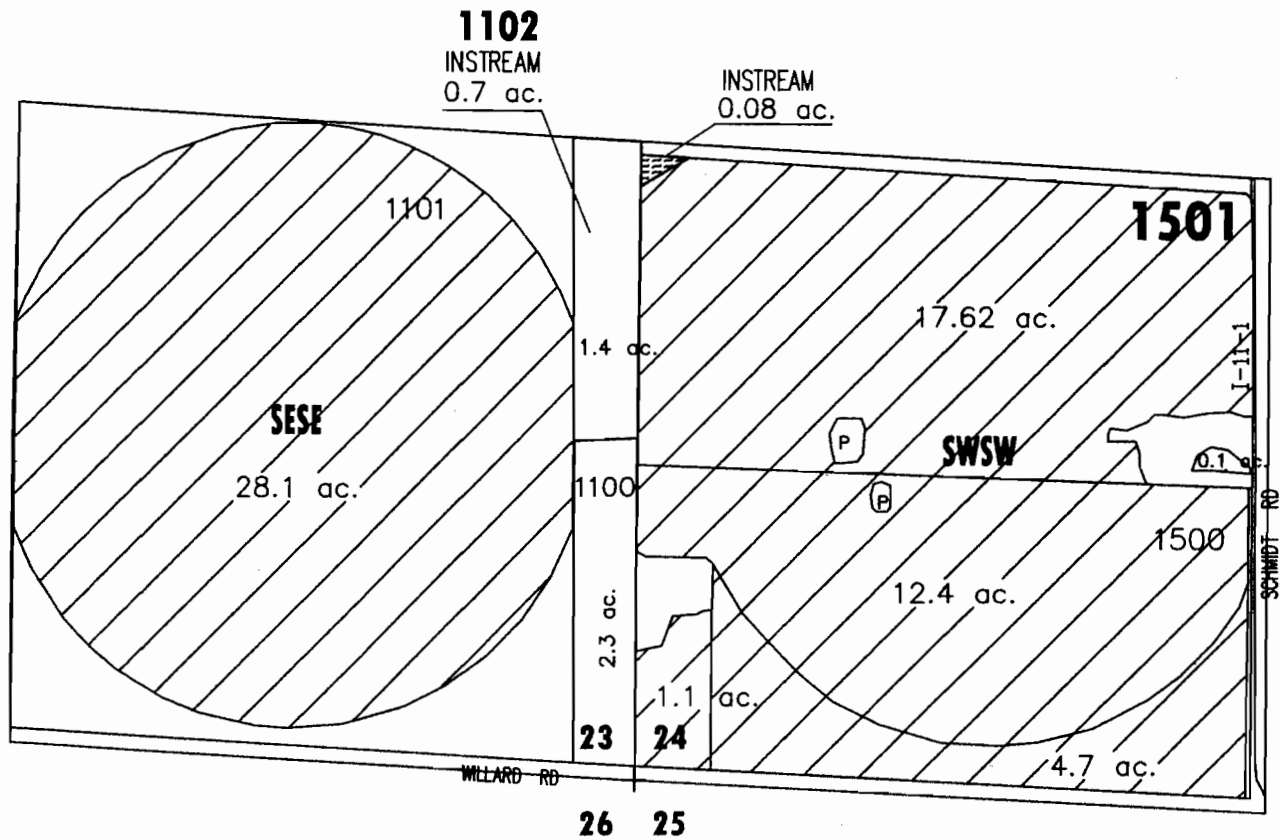

RECEIVED

FEB 27 2009

WATER RESOURCES DEPT
SALEM, OREGON

	'INSTREAM' LANDS
	EXISTING WATER RIGHTS
	'INSTREAM' LAND PARCELS
	PARCELS W/ WATER RIGHTS



APPLICATION FOR 1 YR INSTREAM LEASE

NAME: MELVIN & BETTY JOHNSON

TAXLOT #: 1102, 1501

0.78 ACRES INSTREAM

DATE: 02-09-09

FILE NO: E:\TRANSFER\INSTREAM\INSTRM09\1YR\171423_SESE



State of Oregon
Water Resources Department
 725 Summer Street NE, Suite A
 Salem, Oregon 97301-1266
 (503) 986-0900

Application for Instream Lease

Attachment 5: Pooled Water Right Holder Form

A summary of review criteria and procedures that are generally applicable to these applications is available at www.wrd.state.or.us/OWRD/PUBS/forms.shtml.

Pursuant to ORS 537.348(2) and OAR 690-077

Optional Identification by Lessor/Lessee: 889

Lease Application Number (assigned by WRD): IL-965

This Lease is with:

Lessor #1 (Water Right Holder):

Name Robin Barnes & Patricia Rauch

Mailing address 23966 Dodds Rd

City, State, Zip Code Bend, OR 97701

Telephone number 420-9925

Email address _____

RECEIVED

FEB 27 2009

If additional water right holders, enter water right holder information below

WATER RESOURCES DEPT
 SALEM, OREGON

Note: The section numbering associated with this form corresponds to that found on the "Standard Instream Lease Application" form. The "Pooled Lease" form and "Pooled Water Right Holder" form(s) are used to provide the same information as the "Standard Instream Lease Application" form. Consequently, the numbering on this form is not always sequential.

~I~ Water Right Holder and Water Right Information

1.1 Lessor #1 is the water right holder, or authorized agent for property described in Section 1.5. If the water right appurtenant to these lands is also appurtenant to lands owned by others who are not included in this application, then Attachment 1 (tax lot map), needs to be included.

1.3 For the water right(s) being leased, list all water rights appurtenant to the same lands. Indicate if there are any supplemental or overlying rights.

Certificate No. 83571 & 76714

1.4 Are some or all of the lands being leased part of a Conservation Reserve Enhancement Program. Yes No

1.5 **Water Right(s) Proposed to be Leased Instream.** Water right holder proposes to lease the water rights shown on the map attached as Exhibit 5-B and described as follows:
 [This information may be included on Exhibit 5-A, or an additional map may be attached. Crosshatch the area of water rights being leased. Attached map(s) must identify water right holder, township, range, section and ¼ ¼, tax lot number, map orientation and scale.]

T	R	Sect	1/4	Tax Lot	Acres	Type of Use	Certificate #	Page(s) #	Priority *	
*(Identify pertinent page number of certificate, if certificate is greater than 10 pages; identify priority date if there is more than one per certificate)										
1.	18 S	13 E	11	SE NE	406	0.40	IRRIG	83571	56	10/31/190 0
2.										
3.										
4.										
5.										

Total number of acres, if for irrigation, by certificate and priority date: 0.40 acres Irrigation with a October 31, 1900 priority date

Conditions or other limitations, if any: NONE

If you need to enter another leased right, please use the Additional Water Right Form for Pooled Water Right Holder.

1.6 Validity of rights. Lessor(s) attests (mark one) that:

- The water has been used over the past five years according to the terms and conditions of the water right certificate or as an instream water right or
- The water has not been used over the past five years according to the terms and conditions of the water right certificate, however the water right is not subject to forfeiture under ORS 540.610(2)()(include necessary supporting documentation as Attachment 3).

RECEIVED

FEB 27 2009

WATER RESOURCES DEPT
SALEM, OREGON

~II~ Instream Water Right Information

2.3 Term of lease. This lease shall terminate on October 26, 2009. (If there is a conflict between the Pooled Lease Form and this form, the Pooled Lease Form will be the official term of the lease.)

~III~ Other Information

3.1 Accuracy. The Undersigned Lessor(s) and Lessee(s) declare that, to the best of their knowledge and belief, the information contained in this application is true, correct and complete. If after the lease order is signed, any information is determined to be false, the lease order may be modified or terminated. The lease only exercises the water rights being leased, for the term of the lease. It shall not be construed to overcome any claim that the water right may otherwise be subject to forfeiture for nonuse pursuant to ORS 540.610 during the period of time prior to the execution of the lease.

3.2 Lease. Lessor(s) and Lessee(s) agree to lease the water rights listed in Section(s) 1.5 for instream use for the term of this lease through Lessee to the Trustee, the Oregon Water Resources Department, pursuant to the provisions of ORS 537.348(2) and OAR 690-077.

3.3 Precedent. If a right which has been leased is later proposed to be leased again or transferred to an instream use under ORS 537.348 and OAR 690-077 a new injury review shall be

required, and a prior short term lease shall not set a precedent for the amount of water to be leased or transferred instream.

3.4 Suspension of original use. During the period of the lease, the water right holder agrees to suspend use of water allowed under the subject water rights and under any water right that is supplemental to the subject water rights.

3.5 Termination provision.

- For multiyear leases, the Lessor(s) shall have the option of terminating the lease each year with written notice to the Department. The lease may be terminated at any time during the calendar year. However, if the termination request is received less than 30-days prior to the period of allowed instream use or after the period of allowed use has begun for the water right(s) being leased, water may not be used under the right(s) leased until the following calendar year, unless the Director determines that enlargement would not occur. The Department may also require:
- Written notice to the Department with original signatures;
 - Consent by all parties to the lease; and/or
 - Written notice to the Watermaster's office.
- For multiyear leases, the lessor shall not have the option of terminating the lease, without consent by all parties to the lease.

3.6 Modification to prevent injury. Allocation of water to the instream use described in Section 2.2 during the term of this lease is not reasonably expected to cause injury to other rights to use water from the same source. If injury is found after this lease is signed, the lease may be modified or terminated to prevent injury.

Lessor #1: Robin K. Barnes Date: 11-5-08
Robin Barnes

For additional Lessors, type in space for signature and date
Patricia S. Rauch Date: 11-5-08
Patricia Rauch

Other Attachments As Needed:

- Exhibit 5-A: Tax Lot Map. (See instructions.)
Exhibit 5-B: Detailed map illustrating lands under subject rights to be leased; required if only part of a right is being leased instream. Exhibits 5-A and 5-B may be combined into a single map. (See instructions.)
Exhibit 5-C: Supporting documentation indicating why a right is valid and not subject to forfeiture even though the right has not been exercised for five or more consecutive years (required if the second box in Section 1.6 of this form is checked)
Exhibit 5-D: Split Season Instream Use Form

RECEIVED
FEB 27 2009
WATER RESOURCES DEPT
SALEM, OREGON

**DESCHUTES COUNTY
SEC. 11 T18S. R13E. W.M.**

SCALE - 1" = 400'



SE 1/4 OF THE NE 1/4

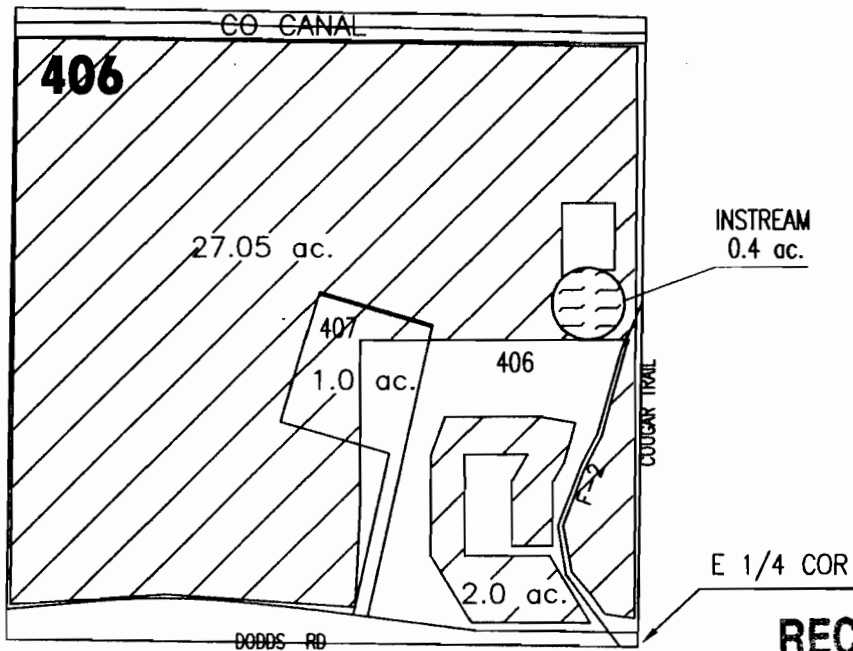

RECEIVED

FEB 27 2009

WATER RESOURCES DEPT
SALEM, OREGON

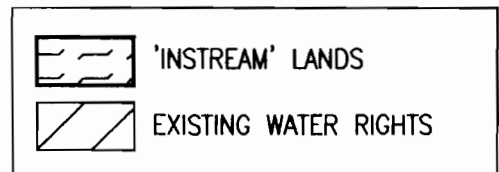

APPLICATION FOR 1 YR INSTREAM LEASE

NAME: PATRICIA RAUCH & ROBIN BARNES

TAXLOT #: 406

0.4 ACRES INSTREAM

DATE: 02-09-09

FILE NO: E:\TRANSFER\INSTREAM\INSTRM09\1YR\181311_SENE



State of Oregon
Water Resources Department
725 Summer Street NE, Suite A
Salem, Oregon 97301-1266
(503) 986-0900

Application for Instream Lease

Attachment 5: Pooled Water Right Holder Form

A summary of review criteria and procedures that are generally applicable to these applications is available at www.wrd.state.or.us/OWRD/PUBS/forms.shtml.

Pursuant to ORS 537.348(2) and OAR 690-077

Optional Identification by Lessor/Lessee: 2773
Lease Application Number (assigned by WRD): IL-965

This Lease is with:

Lessor #1 (Water Right Holder):

Name Sage Wind Farms, LLC
Mailing address 65140 Collins Rd
City, State, Zip Code Bend, OR 97701
Telephone number _____
Email address _____

RECEIVED

FEB 27 2009

WATER RESOURCES DEPT
SALEM, OREGON

If additional water right holders, enter water right holder information below

Note: The section numbering associated with this form corresponds to that found on the "Standard Instream Lease Application" form. The "Pooled Lease" form and "Pooled Water Right Holder" form(s) are used to provide the same information as the "Standard Instream Lease Application" form. Consequently, the numbering on this form is not always sequential.

~I~ Water Right Holder and Water Right Information

1.1 Lessor #1 is the water right holder, or authorized agent for property described in Section 1.5. If the water right appurtenant to these lands is also appurtenant to lands owned by others who are not included in this application, then Attachment 1 (tax lot map), needs to be included.

1.3 For the water right(s) being leased, list all water rights appurtenant to the same lands. Indicate if there are any supplemental or overlying rights.

Certificate No. 83571 & 76714

1.4 Are some or all of the lands being leased part of a Conservation Reserve Enhancement Program. Yes No

1.5 Water Right(s) Proposed to be Leased Instream. Water right holder proposes to lease the water rights shown on the map attached as Exhibit 5-B and described as follows:
[This information may be included on Exhibit 5-A, or an additional map may be attached. Crosshatch the area of water rights being leased. Attached map(s) must identify water right holder, township, range, section and ¼ ¼, tax lot number, map orientation and scale.]

T	R	Sect	¼¼	Tax Lot	Acres	Type of Use	Certificate #	Page(s) #	Priority*	
*(Identify pertinent page number of certificate, if certificate is greater than 10 pages; identify priority date if there is more than one per certificate)										
1.	17 S	12 E	23	SE NE	115	8.00	Irrigation	83571	43	10/31/190 0
2.										
3.										
4.										
5.										

Total number of acres, if for irrigation, by certificate and priority date: Cert #83571, Oct. 31, 1900 - 8.00 acres

Conditions or other limitations, if any: None

If you need to enter another leased right, please use the Additional Water Right Form for Pooled Water Right Holder.

1.6 Validity of rights. Lessor(s) attests (mark one) that:

- The water has been used over the past five years according to the terms and conditions of the water right certificate or as an instream water right or
- The water has not been used over the past five years according to the terms and conditions of the water right certificate, however the water right is not subject to forfeiture under ORS 540.610(2)()(include necessary supporting documentation as Attachment 3).

RECEIVED
FEB 27 2009
WATER RESOURCES DEPT
SALEM, OREGON

~II~ Instream Water Right Information

2.3 Term of lease. This lease shall terminate on October 31, 2009. (If there is a conflict between the Pooled Lease Form and this form, the Pooled Lease Form will be the official term of the lease.)

~III~ Other Information

3.1 Accuracy. The Undersigned Lessor(s) and Lessee(s) declare that, to the best of their knowledge and belief, the information contained in this application is true, correct and complete. If after the lease order is signed, any information is determined to be false, the lease order may be modified or terminated. The lease only exercises the water rights being leased, for the term of the lease. It shall not be construed to overcome any claim that the water right may otherwise be subject to forfeiture for nonuse pursuant to ORS 540.610 during the period of time prior to the execution of the lease.

3.2 Lease. Lessor(s) and Lessee(s) agree to lease the water rights listed in Section(s) 1.5 for instream use for the term of this lease through Lessee to the Trustee, the Oregon Water Resources Department, pursuant to the provisions of ORS 537.348(2) and OAR 690-077.

3.3 Precedent. If a right which has been leased is later proposed to be leased again or transferred to an instream use under ORS 537.348 and OAR 690-077 a new injury review

shall be required, and a prior short term lease shall not set a precedent for the amount of water to be leased or transferred instream.

3.4 Suspension of original use. During the period of the lease, the water right holder agrees to suspend use of water allowed under the subject water rights and under any water right that is supplemental to the subject water rights.

3.5 Termination provision.

- For multiyear leases, the Lessor(s) shall have the option of terminating the lease each year with written notice to the Department. The lease may be terminated at any time during the calendar year. However, if the termination request is received less than 30-days prior to the period of allowed instream use or after the period of allowed use has begun for the water right(s) being leased, water may not be used under the right(s) leased until the following calendar year, unless the Director determines that enlargement would not occur. The Department may also require:
 - Written notice to the Department with original signatures;
 - Consent by all parties to the lease; and/or
 - Written notice to the Watermaster's office.
- For multiyear leases, the lessor shall not have the option of terminating the lease, without consent by all parties to the lease.

3.6 Modification to prevent injury. Allocation of water to the instream use described in Section 2.2 during the term of this lease is not reasonably expected to cause injury to other rights to use water from the same source. If injury is found after this lease is signed, the lease may be modified or terminated to prevent injury.

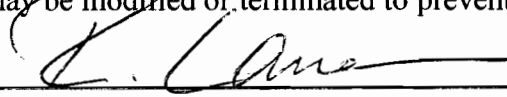
Lessor #1:  Date: 2-1-09
Sage Wind Farms, LLC

For additional Lessors, type in space for signature and date

RECEIVED
FEB 27 2009
WATER RESOURCES DEPT
SALEM, OREGON

Other Attachments As Needed:

- Exhibit 5-A: Tax Lot Map. (See instructions.)
- Exhibit 5-B: Detailed map illustrating lands under subject rights to be leased; required if only part of a right is being leased instream. Exhibits 5-A and 5-B may be combined into a single map. (See instructions.)
- Exhibit 5-C: Supporting documentation indicating why a right is valid and not subject to forfeiture even though the right has not been exercised for five or more consecutive years (required if the second box in Section 1.6 of this form is checked)
- Exhibit 5-D: Split Season Instream Use Form

DESCHUTES COUNTY SEC. 23 T17S. R12E. W.M.

SCALE - 1" = 400'



SE 1/4 OF THE NE 1/4

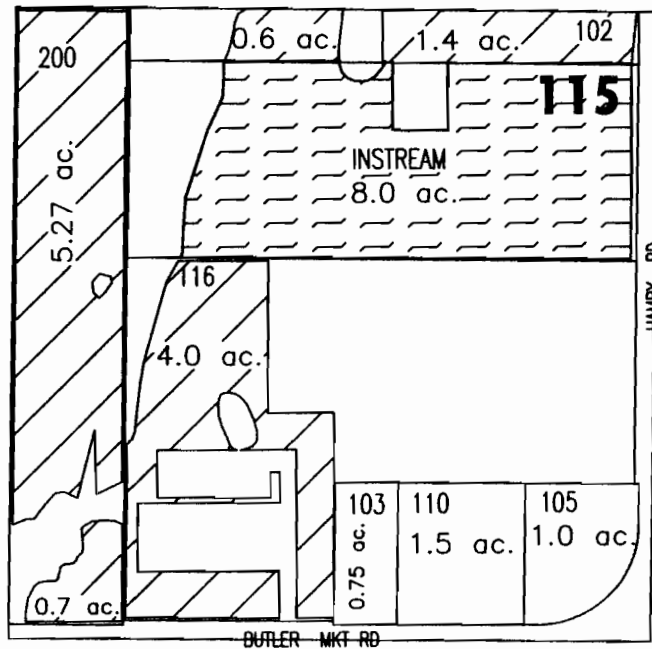

RECEIVED

FEB 27 2009

WATER RESOURCES DEPT
SALEM, OREGON

	'INSTREAM' LANDS
	EXISTING WATER RIGHTS
	PARCELS W/ WATER RIGHTS



APPLICATION FOR 1 YR INSTREAM LEASE

NAME: SAGE WIND FARMS, LLC

TAXLOT #: 115

8.0 ACRES INSTREAM

DATE: 02-06-09

FILE NO: E:\TRANSFER\INSTREAM\INSTRM09\1YR\171223_SENE