

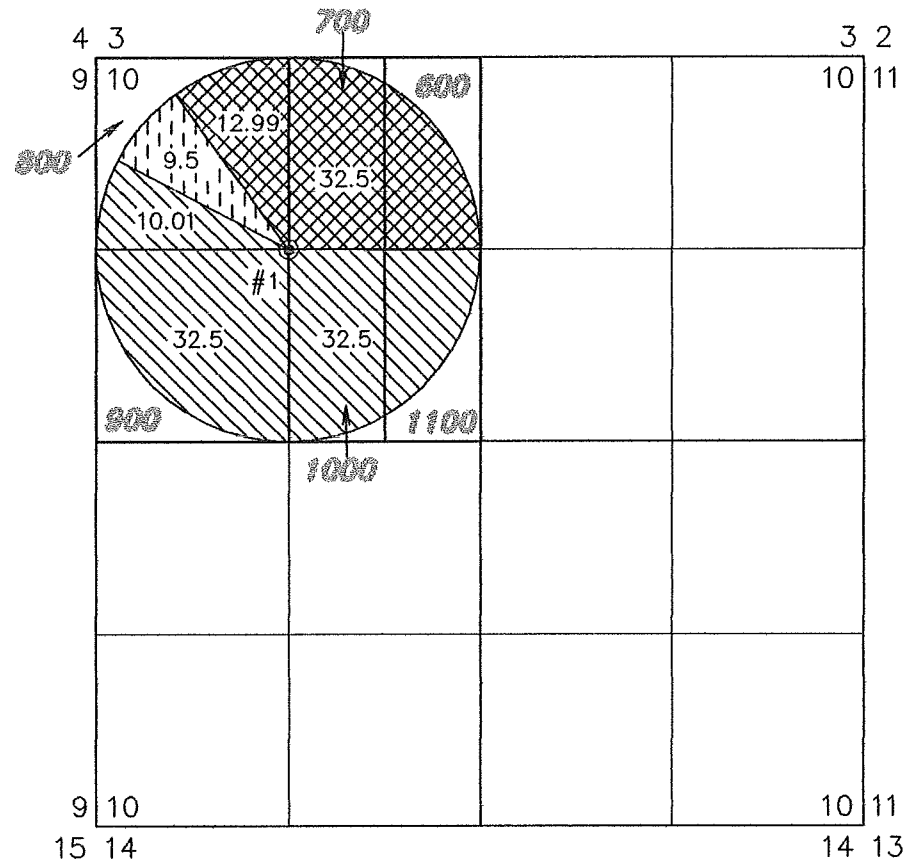



MAP TO ACCOMPANY APPLICATION
TO CHANGE PLACE OF USE
AND POINT OF APPROPRIATION
FOR
LARRY AND TARA GRASSMAN

TAX LOTS 600, 700, 800, 900, 1000, & 1100
IN SECTION 10, TOWNSHIP 28 SOUTH, RANGE 16 EAST, W.M.
LAKE COUNTY, OREGON

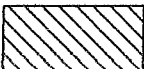

● #1 WELL LOCATED IN THE SW 1/4 NW 1/4 SECTION 10, T28S R16E, W.M. LOCATED 1320 FEET SOUTH AND 1320 FEET EAST FROM THE NW CORNER OF SECTION 10.

-  45.49 ACRES WATER RIGHTS TO BE TRANSFERRED FROM CERTIFICATE No. 83124 (G-10701), AS SHOWN.
-  75.51 ACRES WATER RIGHT TRANSFERRED, SEE T-10231.
-  9.5 ACRES WATER RIGHT TRANSFERRED, SEE T-10284.

RECEIVED



MAR 22 2010

WATER RESOURCES DEPT
SALEM, OREGON

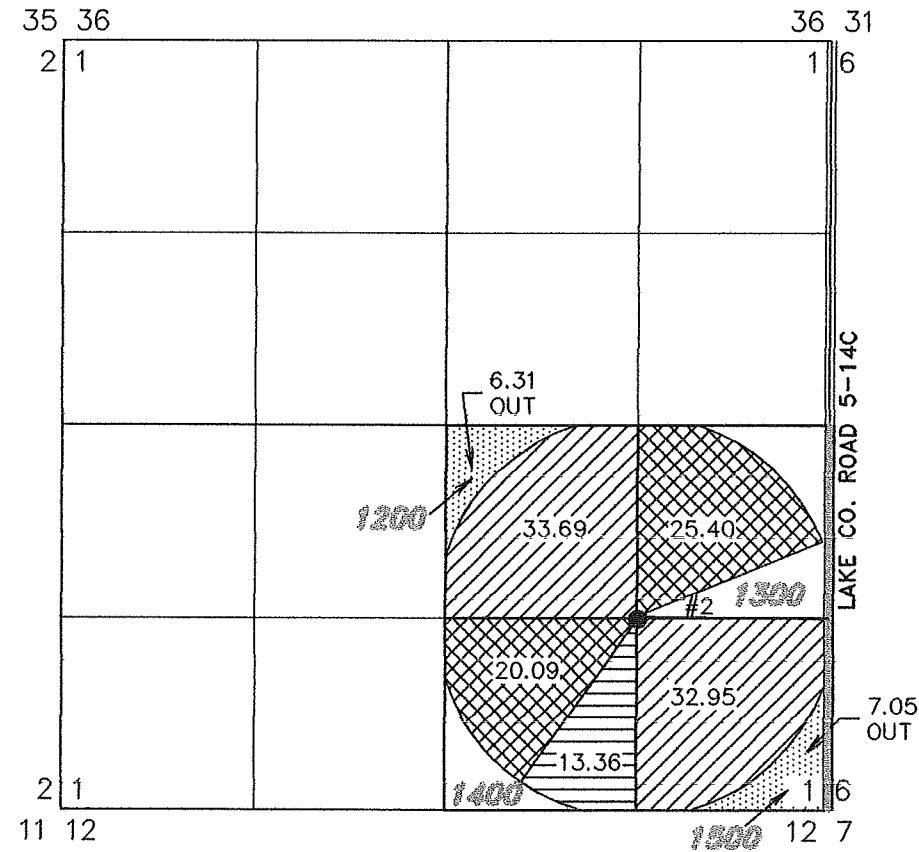
TAX LOTS 1200, 1300, 1400, & 1500
IN SECTION 1, TOWNSHIP 27 SOUTH, RANGE 17 EAST, W.M.
LAKE COUNTY, OREGON

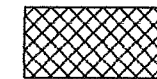

● #2 WELL LOCATED IN THE SE 1/4 SE 1/4 SECTION 1, T27S R17E, W.M. LOCATED 1311 FEET NORTH AND 1310 FEET WEST FROM THE SE CORNER OF SECTION 1.

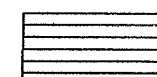
-  45.49 ACRES WATER RIGHTS TO BE TRANSFERRED FROM CERTIFICATE No. 83124 (G-10701), AS SHOWN.
-  66.64 ACRES WATER RIGHTS TO REMAIN FROM CERTIFICATE No. 79432 (G-9205), AS SHOWN.
-  13.36 ACRES WATER RIGHTS TO BE TRANSFERRED OUT FROM CERTIFICATE No. 79432 (G-9205), AS SHOWN.
-  13.36 ACRES WATER RIGHTS TO BE TRANSFERRED IN FROM CERTIFICATE No. 79432 (G-9205), AS SHOWN.

THIS MAP IS FOR THE PURPOSE OF LOCATING A WATER RIGHT ONLY AND HAS NO INTENT TO PROVIDE LEGAL DIMENSIONS OR THE LOCATION OF PROPERTY LINES.

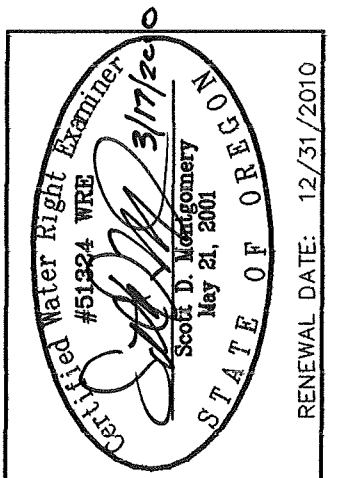

ALL POINTS ENGINEERING
& SURVEYING, INC.

P.O. BOX 767 (CRR)
TERREBONNE, OREGON 97760
(541) 548-5833 PH
(541) 585-4602 FX
WWW.APEandS.com

PROJECT No. 10-004
PREPARED AT THE REQUEST OF:
LARRY AND TARA GRASSMAN
P.O. BOX 101
CHRISTMAS VALLEY, OR 97641