

TRANSFER MAP TO ACCOMPANY APPLICATION TO CHANGE PLACE OF USE & POINTS OF APPROPRIATION FOR J.R.S. PROPERTIES III, LLP

"FROM" TAX LOT 500
IN SECTIONS 7, 8, 17, AND 18, TOWNSHIP 33 SOUTH, RANGE 19 EAST, W.M.
LAKE COUNTY, OREGON

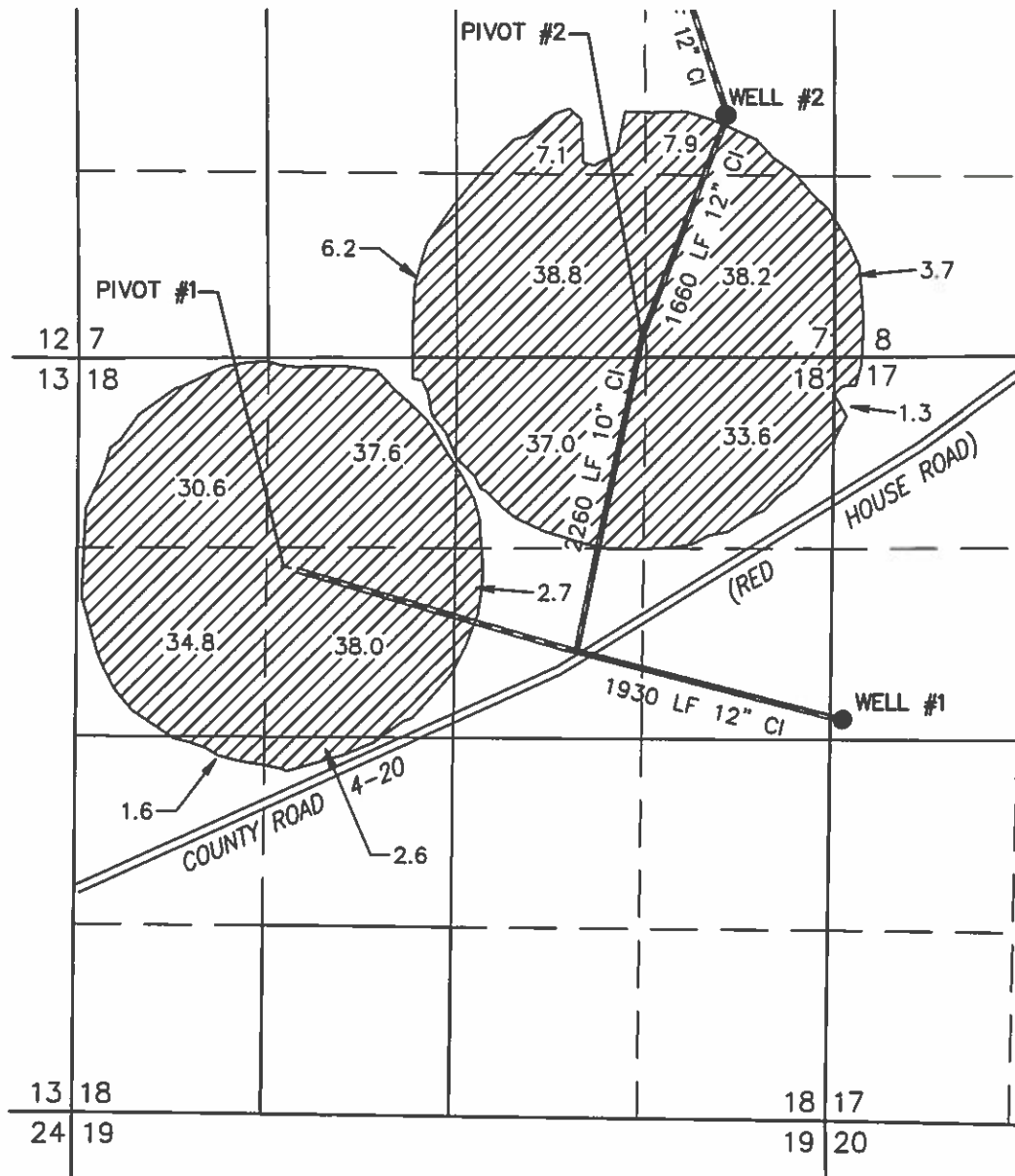

"TO" TAX LOT 200
IN SECTIONS 14 & 23, TOWNSHIP 34 SOUTH, RANGE 19 EAST, W.M.
LAKE COUNTY, OREGON

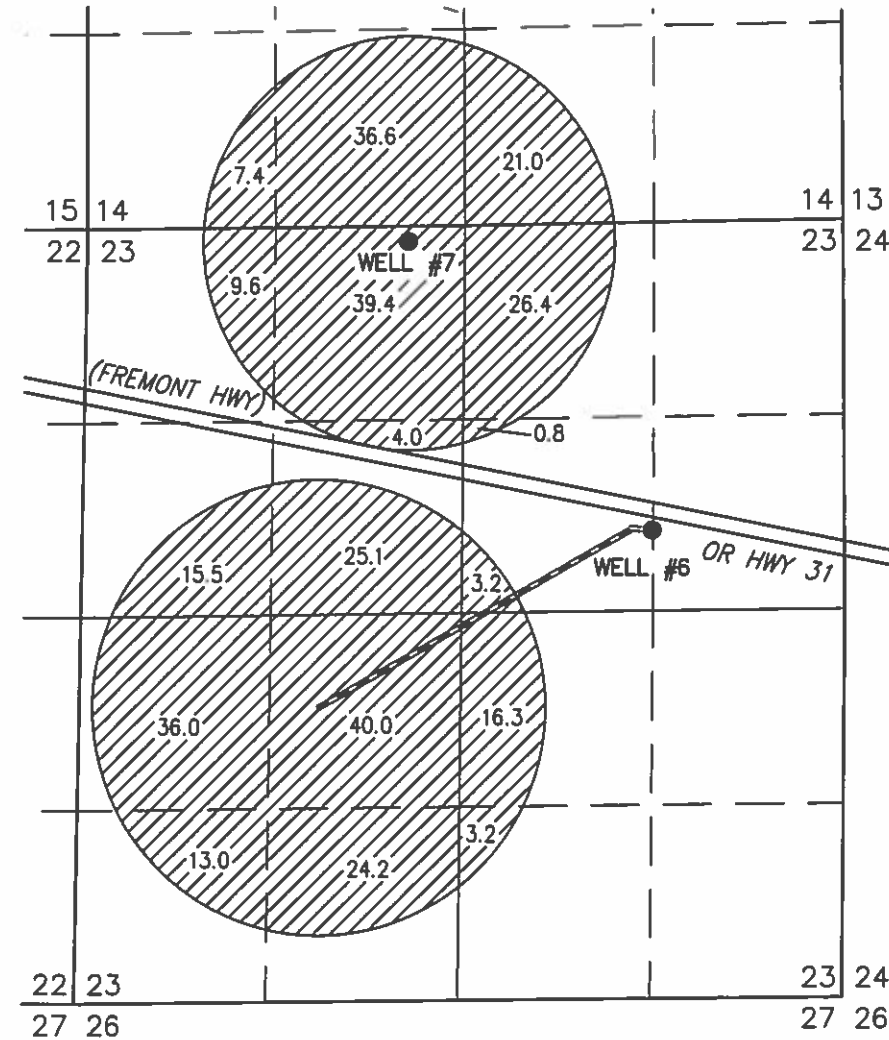

- WELL #1 (LAKE 1667-G13505) IN THE SW 1/4 NW 1/4 SECTION 17, T33S R19E, W.M. LOCATED 2600 FEET SOUTH AND 50 FEET EAST FROM THE NW CORNER OF SECTION 17.
- WELL #2 (LAKE 51182-G13505) IN THE NE 1/4 SE 1/4 SECTION 7, T33S R19E, W.M. LOCATED 1690 FEET SOUTH AND 770 FEET WEST FROM THE SE CORNER OF SECTION 7.
- WELL #6 (LAKE 1719 PROPOSED) IN THE SW 1/4 NE 1/4 SECTION 23, T34S R19E, W.M. LOCATED 570.9 FEET NORTH AND 1332.8 FEET WEST FROM THE E 1/4 CORNER OF SECTION 23.
- WELL #7 (LAKE 52463 PROPOSED) IN THE NE 1/4 NW 1/4 SECTION 23, T34S R19E, W.M. LOCATED 105 FEET SOUTH AND 3000 FEET WEST FROM THE NE CORNER OF SECTION 23.

321.7 ACRES PRIMARY GROUND WATER RIGHTS FROM CERTIFICATE #86190 (G-13505) TRANSFERRED AS SHOWN.

THIS MAP IS FOR THE PURPOSE OF LOCATING A WATER RIGHT ONLY AND HAS NO INTENT TO PROVIDE LEGAL DIMENSIONS OR THE LOCATION OF PROPERTY LINES.

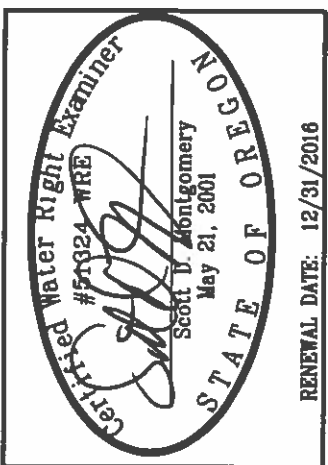

ALL POINTS ENGINEERING & SURVEYING, INC.

P.O. BOX 767
TERREBONNE, OREGON 97760
(541) 548-5833 PH
Scott@APEandS.com
www.APEandS.com

PROJECT No. 15-128

PREPARED AT THE REQUEST OF:
JRS PROPERTIES III, LLP
P.O. BOX 27
BOISE, ID 83707

RECEIVED BY OWRD

MAY 16 2016

SALEM, OR

1 12386

TRANSFER MAP TO ACCOMPANY APPLICATION TO CHANGE PLACE OF USE & POINTS OF APPROPRIATION FOR JRS PROPERTIES III, LLP

"FROM" TAX LOT 500
IN SECTIONS 7, 8, 17, AND 18, TOWNSHIP 33 SOUTH, RANGE 19 EAST, W.M.
LAKE COUNTY, OREGON

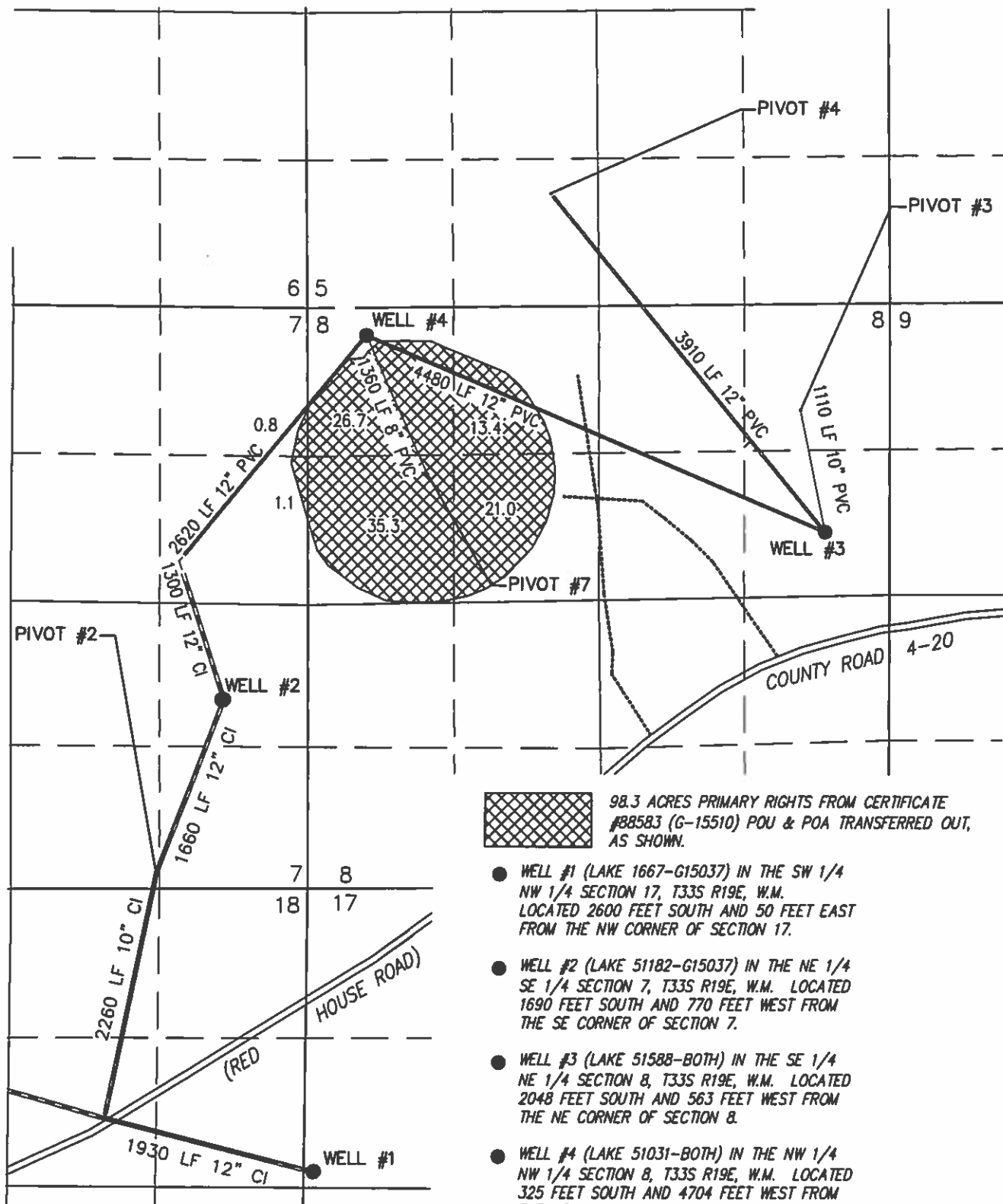

"TO" TAX LOT 200
IN SECTIONS 15 & 22, TOWNSHIP 34 SOUTH, RANGE 19 EAST, W.M.
LAKE COUNTY, OREGON

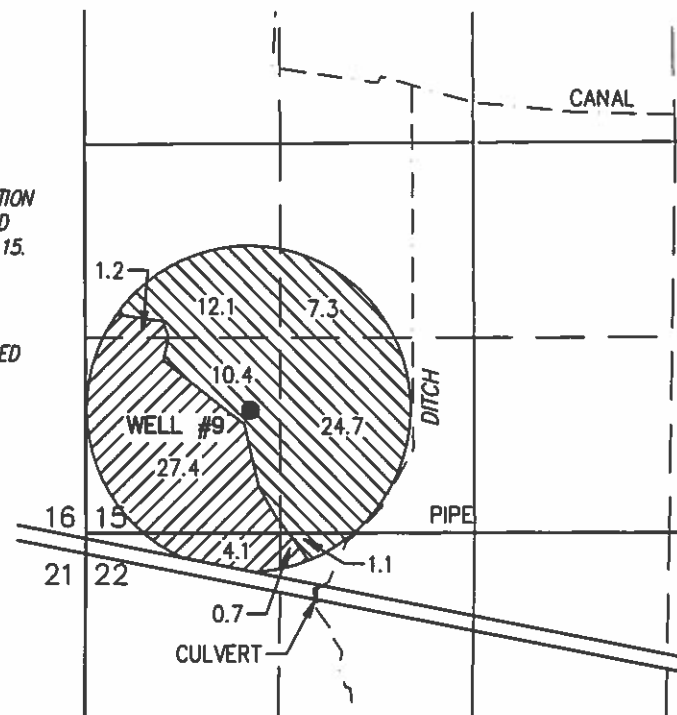

THIS MAP IS FOR THE PURPOSE OF LOCATING A WATER RIGHT ONLY AND HAS NO INTENT TO PROVIDE LEGAL DIMENSIONS OR THE LOCATION OF PROPERTY LINES.

"TO" TAX LOT 200
IN SECTIONS 23, TOWNSHIP 34 SOUTH, RANGE 19 EAST, W.M.
LAKE COUNTY, OREGON

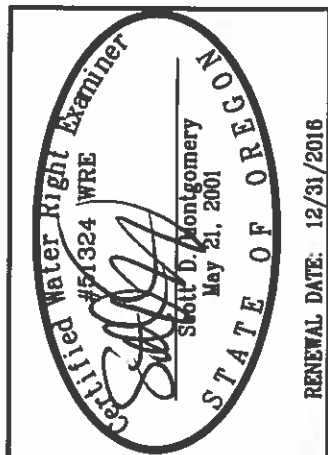
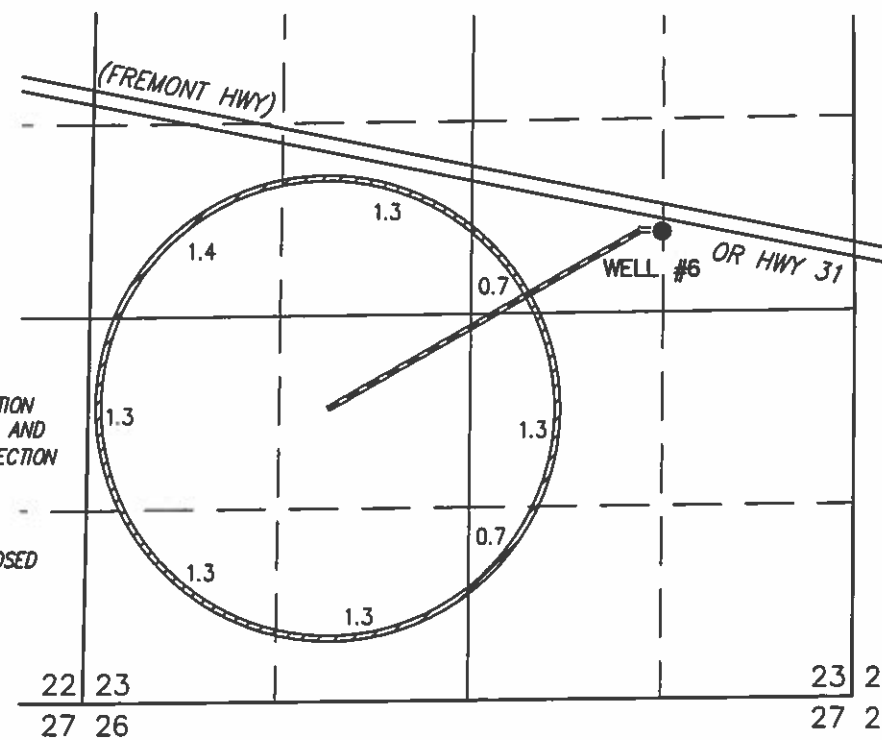

RENEWAL DATE: 12/31/2016

ALL POINTS ENGINEERING & SURVEYING, INC.

P.O. BOX 767
TERREBONNE, OREGON 97760
(541) 548-5833 PH
Scott@APEandS.com
www.APEandS.com

PROJECT No. 15-128

PREPARED AT THE REQUEST OF:
JRS PROPERTIES III, RECEIVED BY OWRD
P.O. BOX 27
BOISE, ID 83707

MAY 16 2016

SALEM, OR

T 12386

TRANSFER MAP TO ACCOMPANY APPLICATION TO CHANGE PLACE OF USE & POINTS OF APPROPRIATION FOR J.R.S. PROPERTIES III, LLP

"FROM" TAX LOT 500
IN SECTIONS 5, 7, 8, 17, AND 18, TOWNSHIP 33 SOUTH, RANGE 19 EAST, W.M.
LAKE COUNTY, OREGON

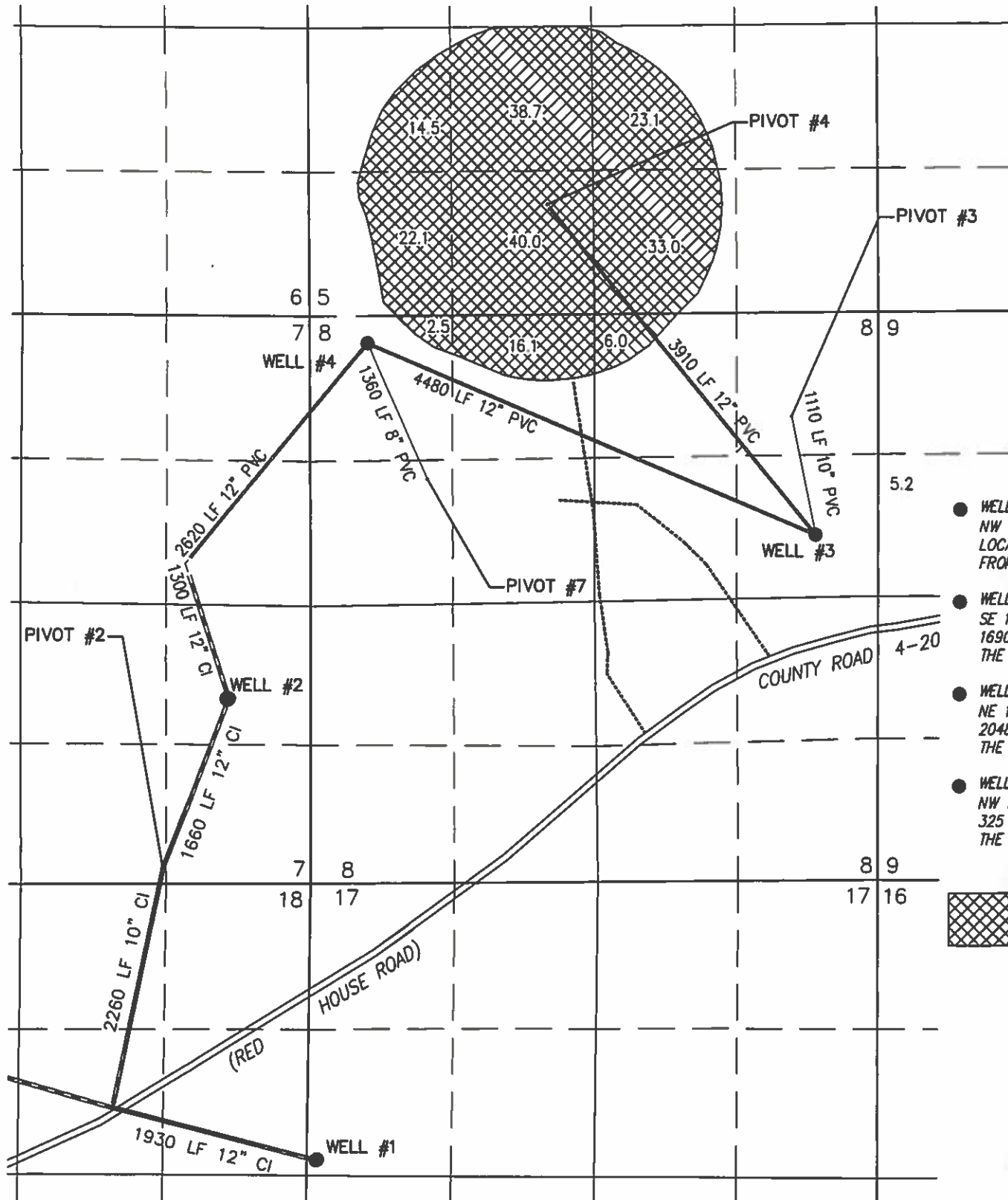

- WELL #1 (LAKE 1867-G15037) IN THE SW 1/4 NW 1/4 SECTION 17, T33S R19E, W.M. LOCATED 2600 FEET SOUTH AND 50 FEET EAST FROM THE NW CORNER OF SECTION 17.
- WELL #2 (LAKE 51182-G15037) IN THE NE 1/4 SE 1/4 SECTION 7, T33S R19E, W.M. LOCATED 1690 FEET SOUTH AND 770 FEET WEST FROM THE SE CORNER OF SECTION 7.
- WELL #3 (LAKE 51588-BOTH) IN THE SE 1/4 NE 1/4 SECTION 8, T33S R19E, W.M. LOCATED 2048 FEET SOUTH AND 563 FEET WEST FROM THE NE CORNER OF SECTION 8.
- WELL #4 (LAKE 51031-BOTH) IN THE NW 1/4 NW 1/4 SECTION 8, T33S R19E, W.M. LOCATED 325 FEET SOUTH AND 4704 FEET WEST FROM THE NE CORNER OF SECTION 8.

196.0 ACRES PRIMARY RIGHTS FROM CERTIFICATE #88594 (G-13714) POU & POA TRANSFERRED OUT, AS SHOWN.

SCALE 4" = 1 MILE

"TO" TAX LOT 200
IN SECTIONS 14, 15, 22, & 23, TOWNSHIP 34 SOUTH, RANGE 19 EAST, W.M.
LAKE COUNTY, OREGON

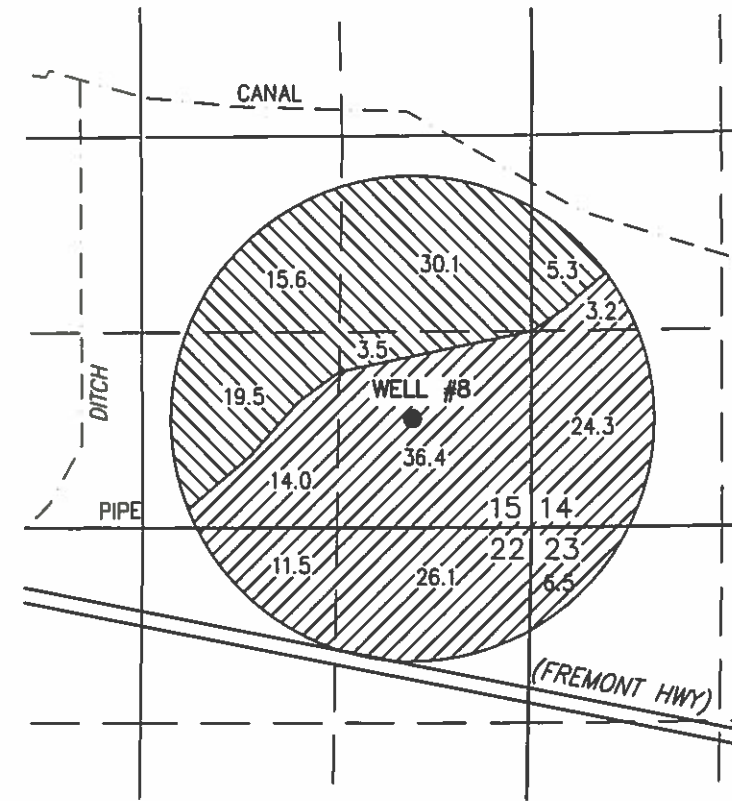

- WELL #8 (LAKE 52491) IN THE SE 1/4 SE 1/4 SECTION 15, T34S R19E, W.M. LOCATED 740 FEET NORTH AND 815 FEET WEST FROM THE SE CORNER OF SECTION 15.

122.0 ACRES PRIMARY RIGHTS FROM CERTIFICATE #88584 (G-13714) POU & POA TRANSFERRED TO PROPOSED PRIMARY, AS SHOWN.

74.0 ACRES PRIMARY GROUND WATER RIGHTS FROM CERTIFICATE #88584 (G-13714) TRANSFERRED TO SUPPLEMENTAL AS SHOWN.

RECEIVED BY OWRD

MAY 16 2016

SALEM, OR

THIS MAP IS FOR THE PURPOSE OF LOCATING A WATER RIGHT ONLY AND HAS NO INTENT TO PROVIDE LEGAL DIMENSIONS OR THE LOCATION OF PROPERTY LINES.

ALL POINTS ENGINEERING & SURVEYING, INC.

P.O. BOX 767
TERREBONNE, OREGON 97760
(541) 548-5833 PH
Scott@APEandS.com
www.APEandS.com

PROJECT No. 15-128

PREPARED AT THE REQUEST OF:
JRS PROPERTIES III, LLP
P.O. BOX 27
BOISE, ID 83707

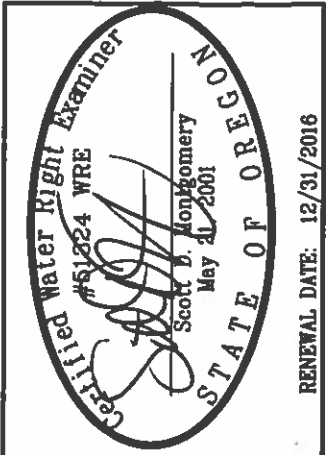

RENEWAL DATE: 12/31/2016