

T. 3N., R. 29E., W.M.

UMATILLA COUNTY

SCALE 1" = 1320'

JAN 22 1988

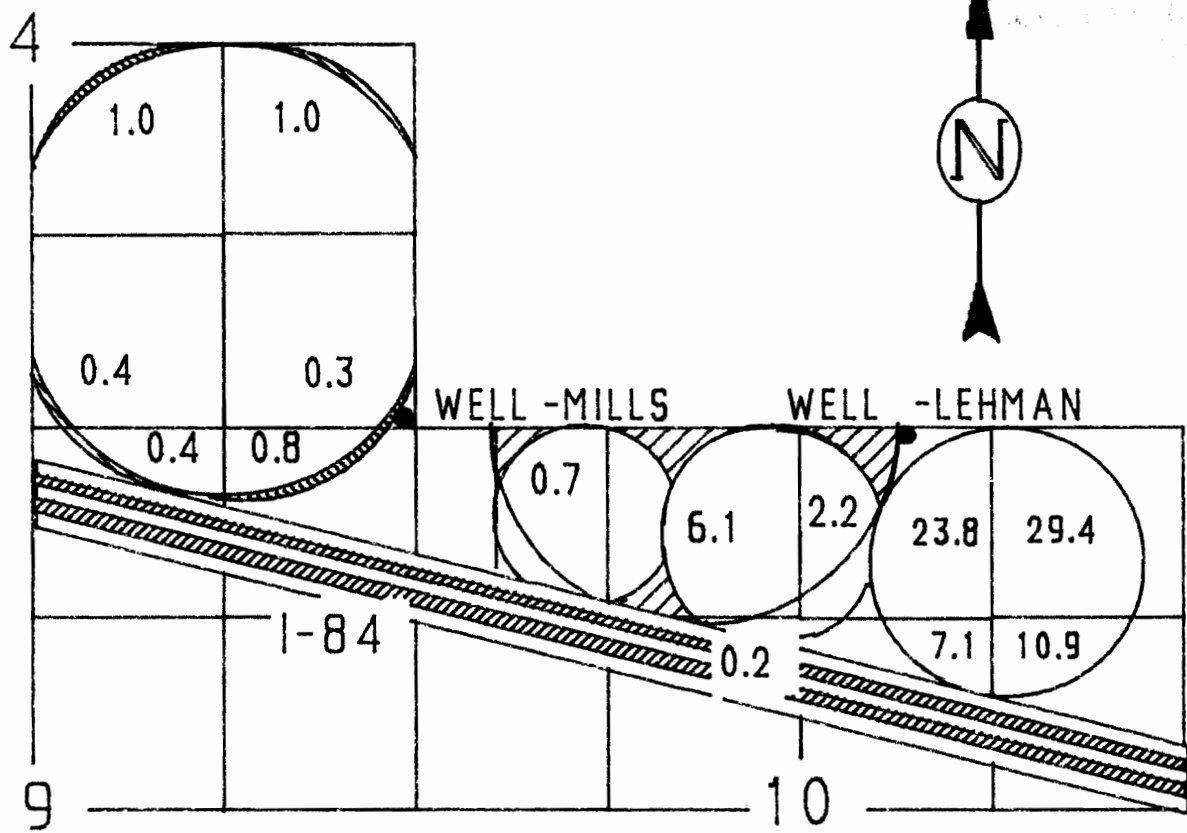

Lehman Well Located at 50' S. & 2020' W. from N.E. Corner Section 10

Mills Well Located at 10' N. & 60' W. from S.E. Corner Section 4

WATER RIGHTS TRANSFER MAP



Water Rights Transferred To This Location T-6442

Water Rights Transferred To This Location T-6443

IN NAME OF

LEHMAN ENTERPRISES, INC. & STEVE & JUDY MILLS

THIS MAP IS FOR THE PURPOSE OF IDENTIFYING THE LOCATION OF WATER RIGHTS ONLY AND IS NOT INTENDED TO PROVIDE THE LEGAL DIMENSIONS OR LOCATIONS OF PROPERTY OWNERSHIP LINES.

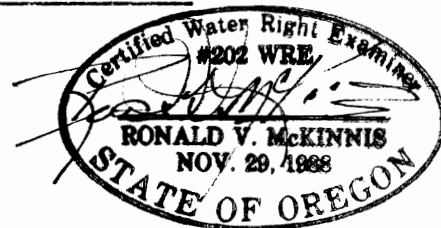

ENGINEERING - SURVEYING - WATER RIGHTS
 R V MCKINNIS ENGINEERING
 Rt 1 Box 1122 Hermiston, Oregon 97838
 503-567-2017