

DESCHUTES COUNTY
SEC.04 T14S. R13E. W.M.

SCALE - 1" = 400'

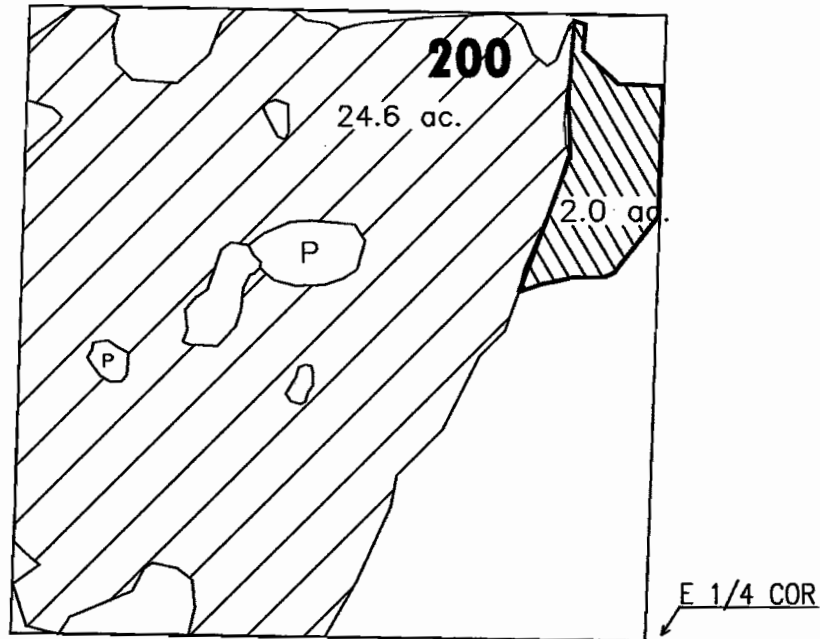

SE 1/4 OF THE NE 1/4



FINAL PROOF MAP

CENTRAL CASCADE CORP. / KEITH RIVERA - 2.0 ACRES

DESCHUTES COUNTY
SEC.05 T14S. R13E. W.M.

SCALE - 1" = 400'



SW1/4 OF THE NW 1/4

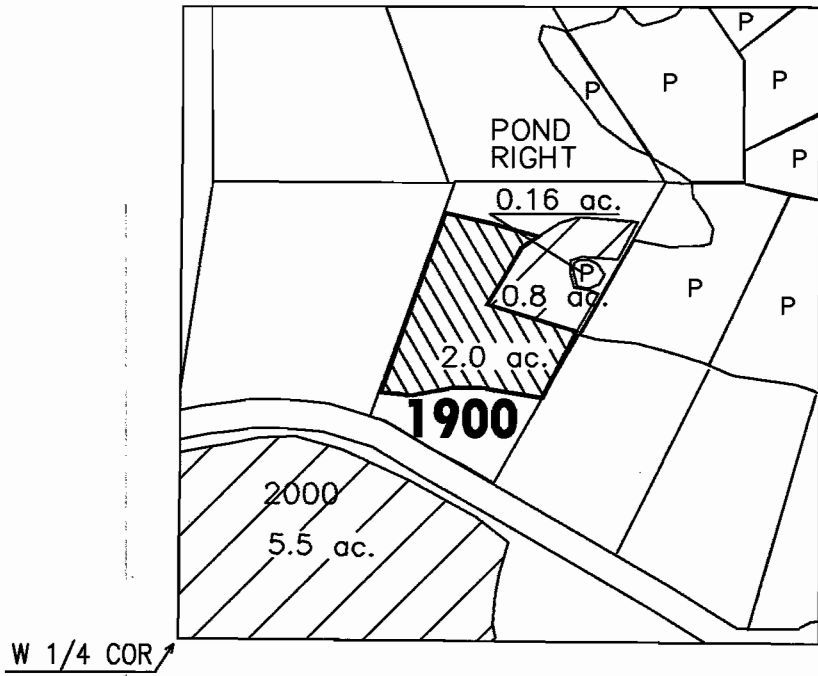

FINAL PROOF MAP

CENTRAL CASCADE CORP./ STEVEN MYRIN - 2.0 ACRES

DESCHUTES COUNTY
SEC.13 T14S. R13E. W.M.

SCALE - 1" = 400'



SW 1/4 OF THE NE 1/4

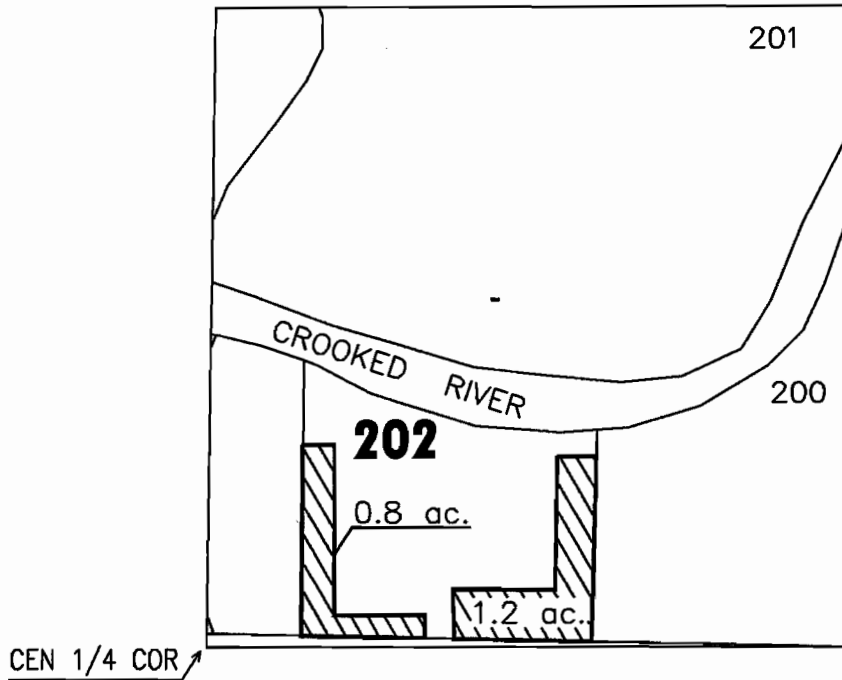

FINAL PROOF MAP

CENTRAL CASCADE LIMITED PARTNERSHIP / BLAKE HANKINS - 2.0 ACRES

DESCHUTES COUNTY
SEC.22 T14S. R13E. W.M.

SCALE - 1" = 400'



SE1/4 OF THE NW 1/4

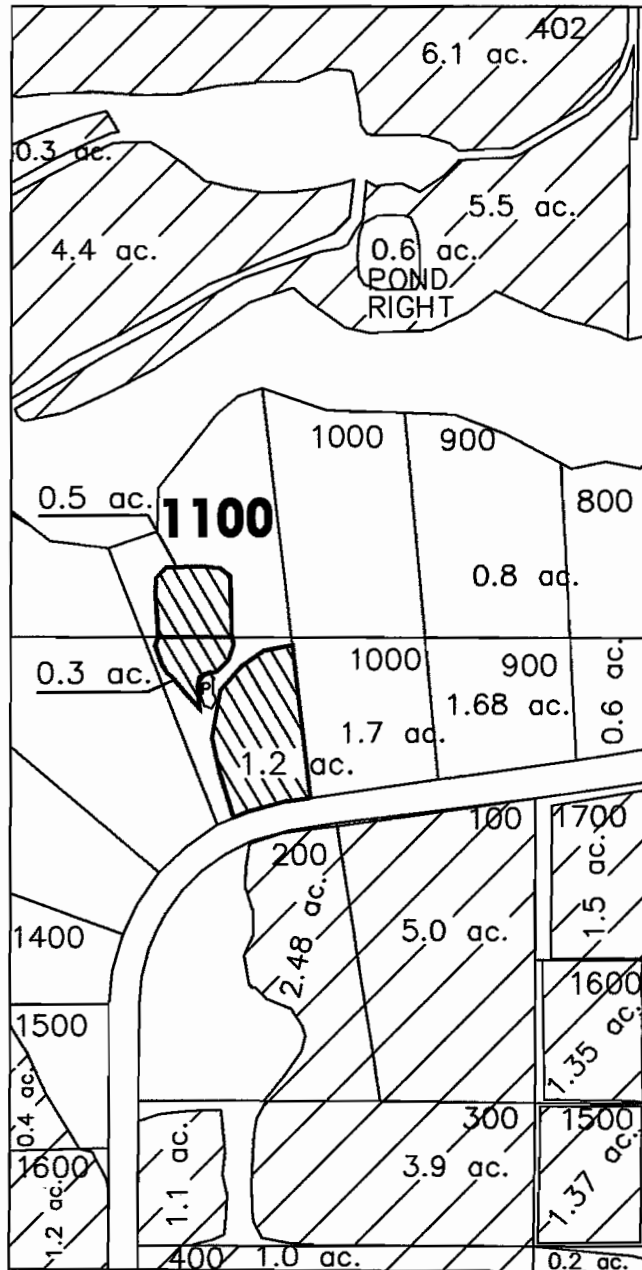

CEN 1/4 COR

NE 1/4 OF THE SW 1/4

FINAL PROOF MAP

CENTRAL CASCADE CORP. / NORMAN MARTTALA - 2.0 ACRES

CROOK COUNTY
SEC.30 T14S. R14E. W.M.

SCALE - 1" = 400'



SW 1/4 OF THE NW 1/4

SE 1/4 OF THE NW 1/4

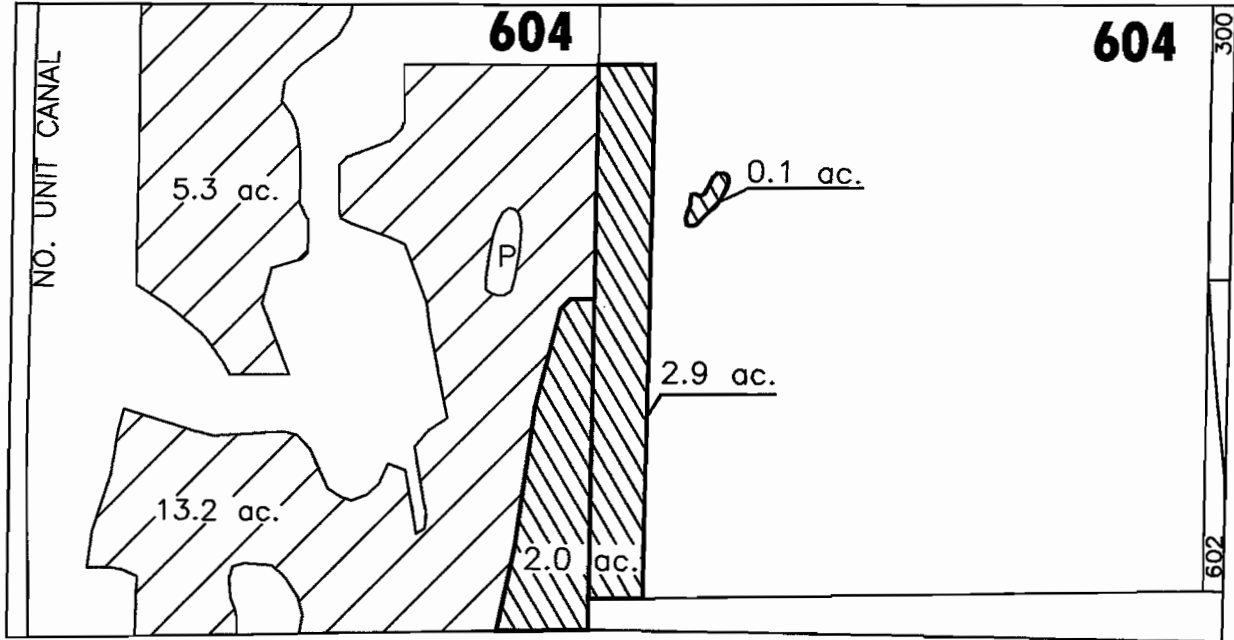

W 1/4 COR

FINAL PROOF MAP

CENTRAL CASCADE CORP. / DUANE RICHARDSON - 5.0 ACRES

DESCHUTES COUNTY
SEC.18 T15S. R13E. W.M.

SCALE - 1" = 400'



NE 1/4 OF THE NE 1/4

7 8

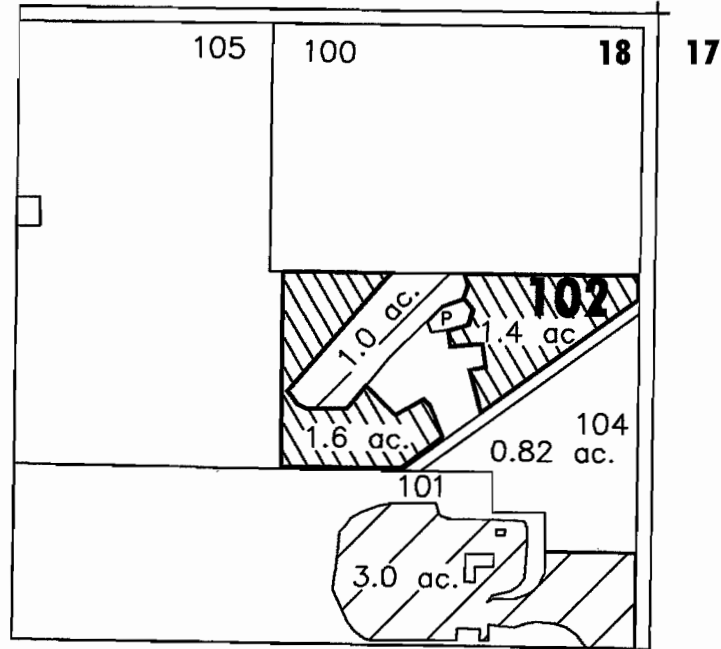

FINAL PROOF MAP

CENTRAL CASCADE CORP. / RON BLAIR - 3.0 ACRES

DESCHUTES COUNTY
SEC.31 T15S. R13E. W.M.

SCALE - 1" = 400'



SE 1/4 OF THE NE 1/4

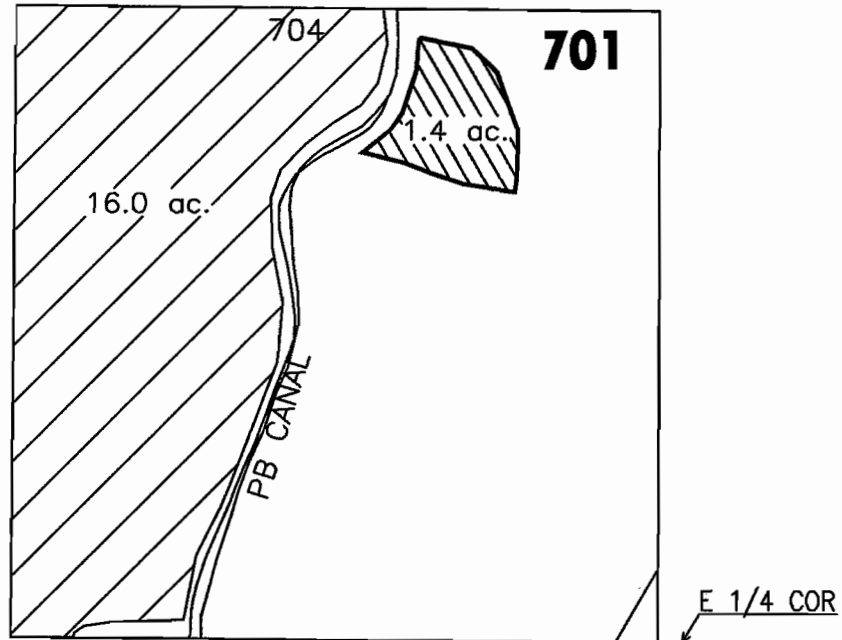

FINAL PROOF MAP

CENTRAL CASCADE CORP. / DAYLENE KNIGHT - 1.4 ACRES

DESCHUTES COUNTY
SEC.31 T15S. R13E. W.M.

SCALE - 1" = 400'



SE 1/4 OF THE NE 1/4

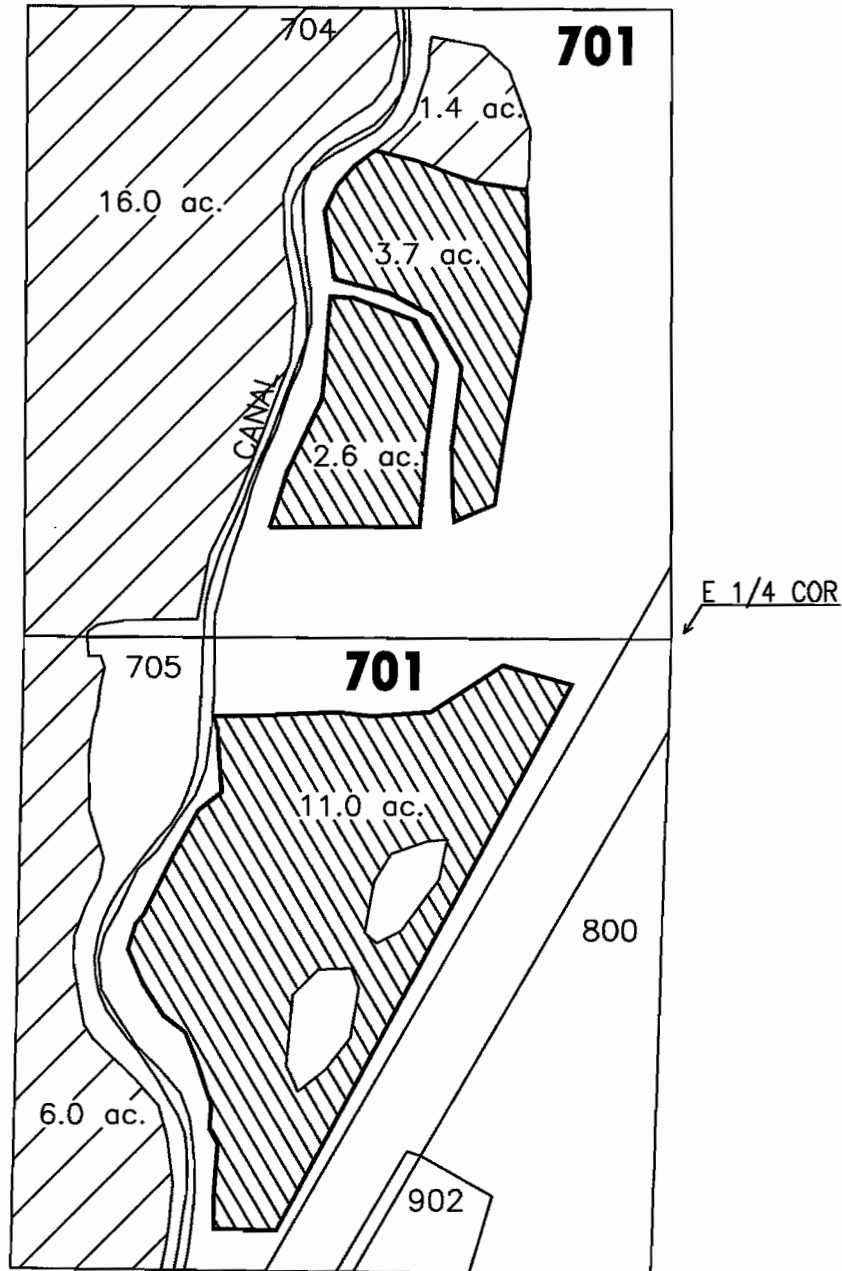

NE 1/4 OF THE SE 1/4

FINAL PROOF MAP

CENTRAL CASCADE LIMITED PARTNERSHIP / DAYLENE KNIGHT - 17.3 ACRES

DESCHUTES COUNTY
SEC.02 T16S. R12E. W.M.

SCALE - 1" = 400'



SE 1/4 OF THE SW 1/4

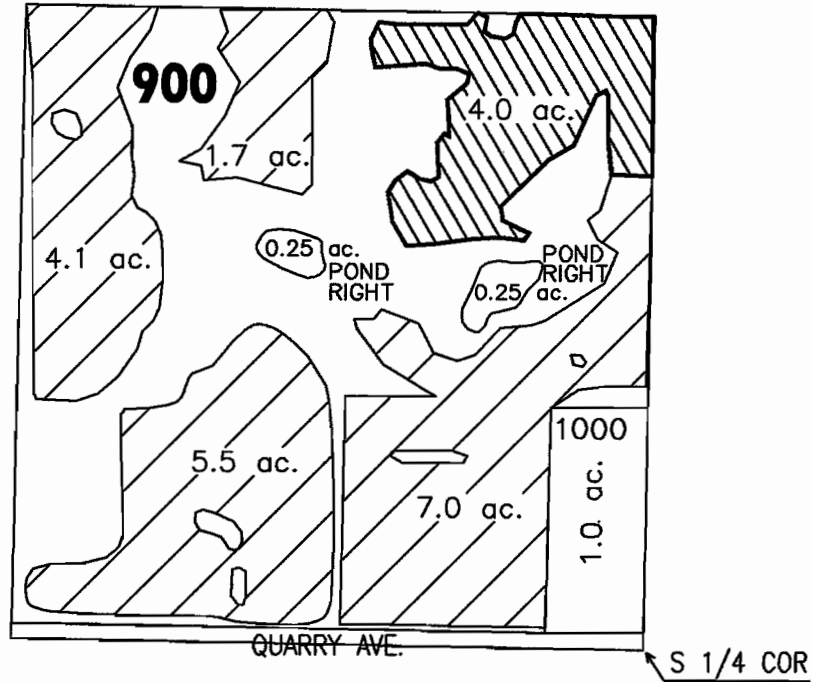

FINAL PROOF MAP

CENTRAL CASCADE CORP. / JOSEPH JONES - 4.0 ACRES

DESCHUTES COUNTY
SEC. 12 T16S. R12E. W.M.

SCALE - 1" = 400'



SW 1/4 OF THE SW 1/4

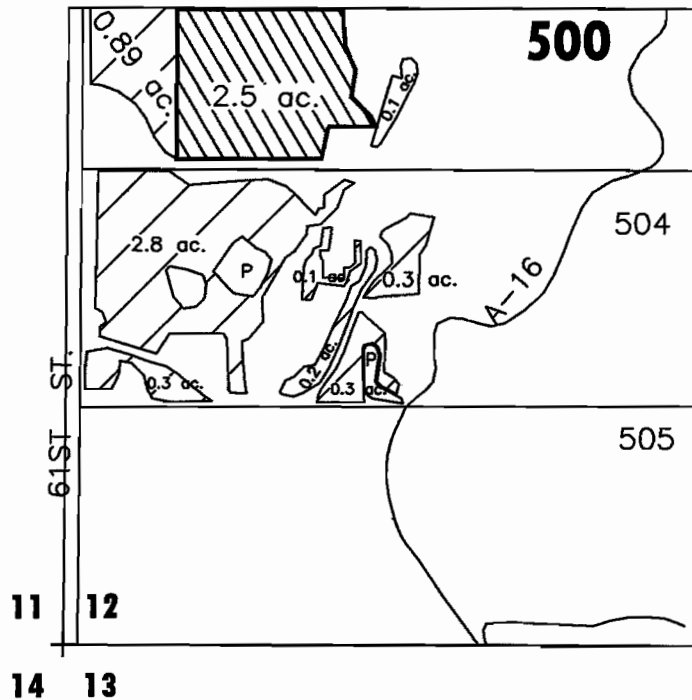

FINAL PROOF MAP

CENTRAL CASCADE CORP. / DENNIS MARSHALL - 2.5 ACRES

DESCHUTES COUNTY
SEC. 11 T17S. R12E. W.M.

SCALE - 1" = 400'

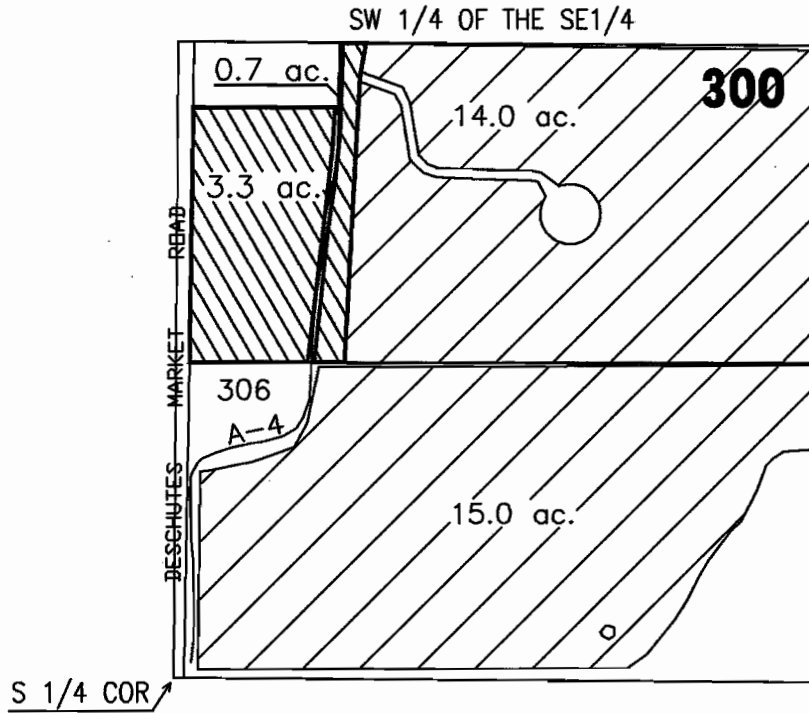

FINAL PROOF MAP

CENTRAL CASCADE CORP. / RYAN G. NOPP - 4.0 ACRES

DESCHUTES COUNTY
SEC.15 T17S. R12E. W.M.

SCALE - 1" = 400'

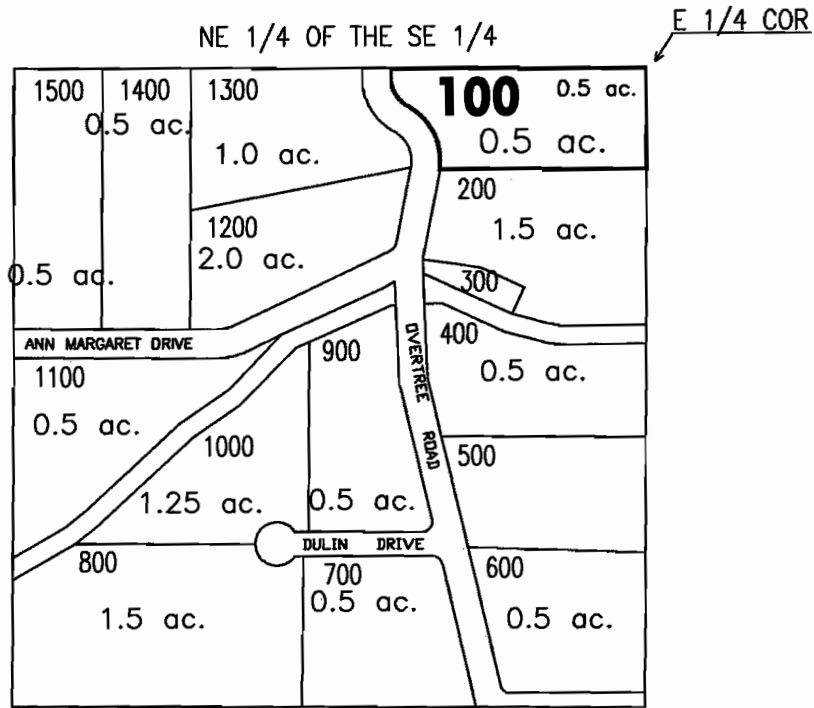

FINAL PROOF MAP

CENTRAL CASCADE CORP. / WILLIAM A. REICHARDT - 0.5 ACRES