

MAP TO ACCOMPANY APPLICATION TO TRANSFER WATER RIGHTS

FOR
 ROBERT BOLTON
 HC 60 BOX 2390
 LAKEVIEW, OR 97630
 (541) 947-2552

*Received
 1/29/98*

EXISTING WATER RIGHTS

SECTION 1
 TOWNSHIP 40 SOUTH
 RANGE 18 EAST, W.M.
 LAKE COUNTY, OREGON

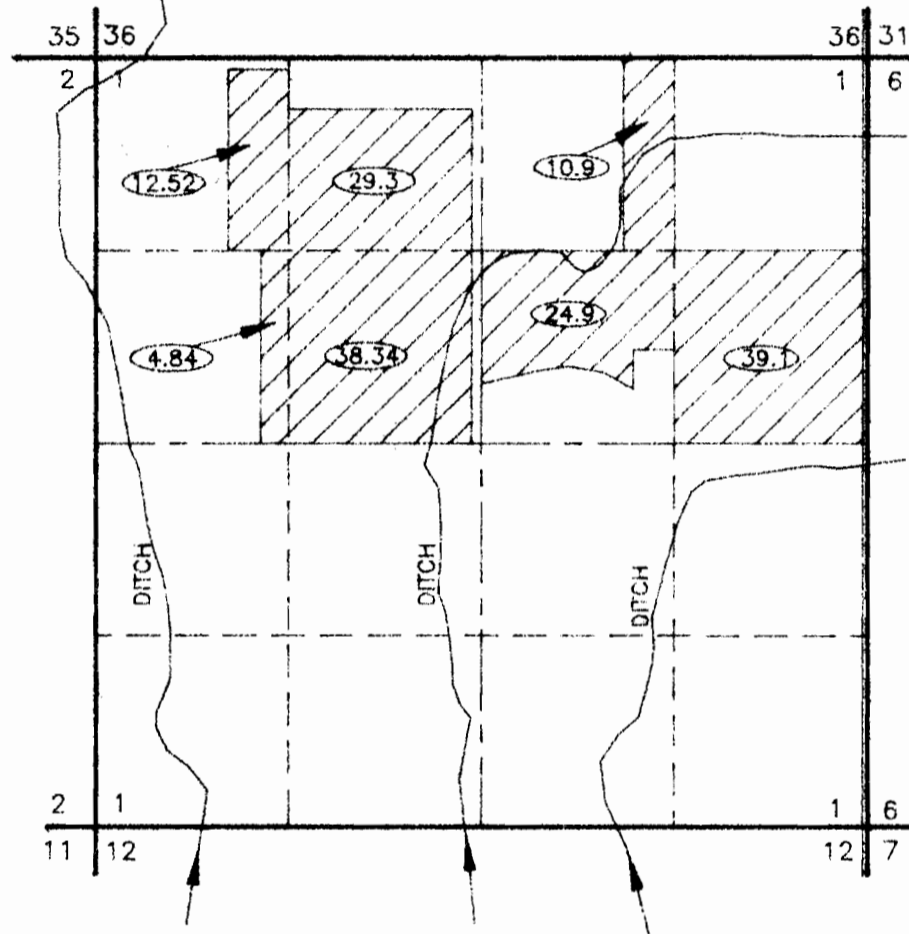

WATER RIGHTS TRANSFER DIAGRAM

SECTION 1
 TOWNSHIP 40 SOUTH
 RANGE 18 EAST, W.M.
 LAKE COUNTY, OREGON

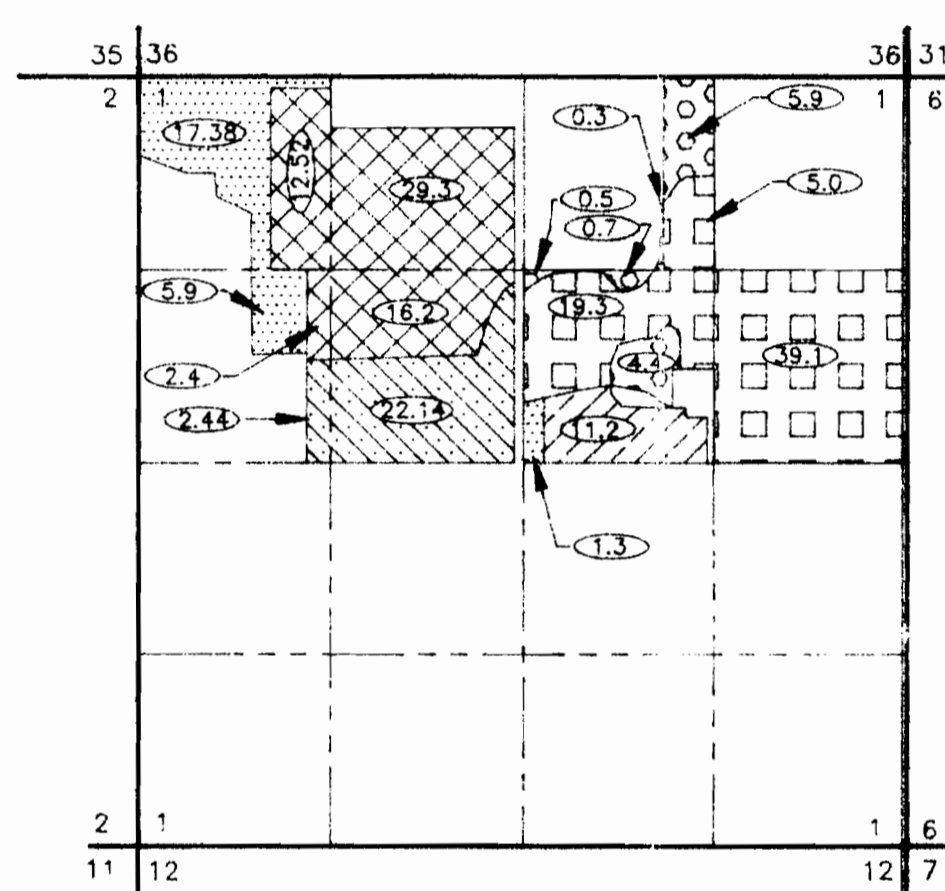

WATER RIGHTS CONFIGURATION AFTER TRANSFER

SECTION 1
 TOWNSHIP 40 SOUTH
 RANGE 18 EAST, W.M.
 LAKE COUNTY, OREGON

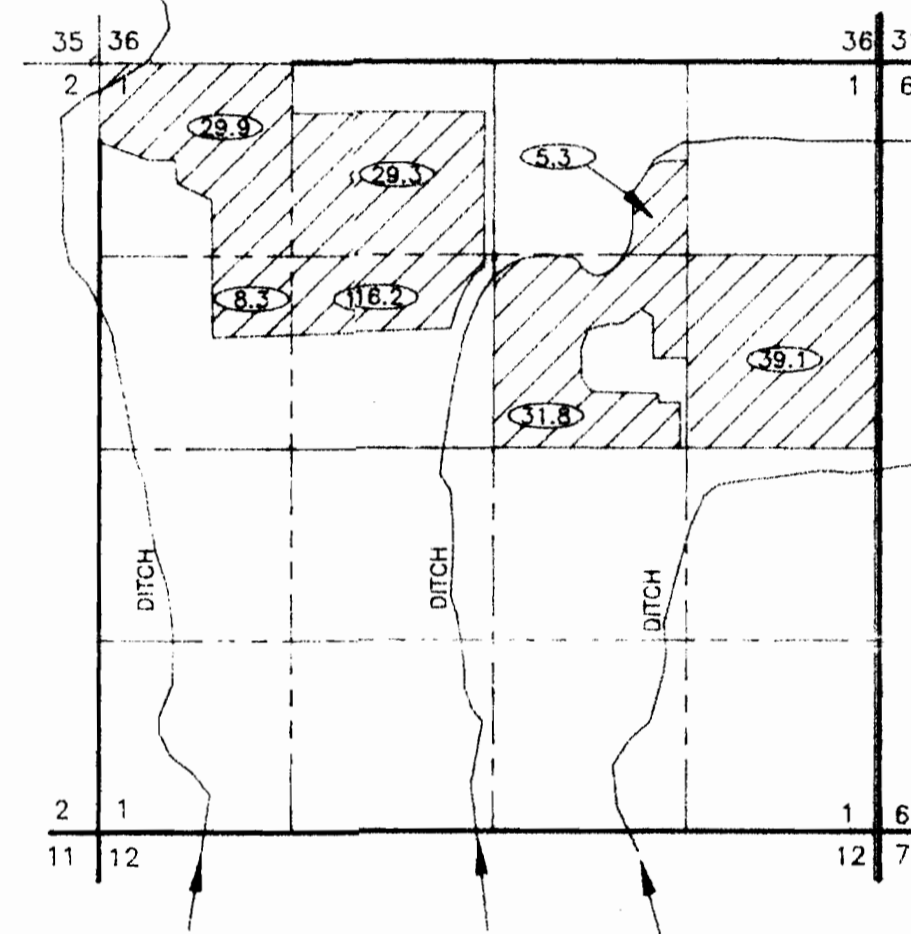

SCALE: 1"=1320'

EXISTING WATER RIGHT ACRES
 LAKEVIEW WATER USERS TRANSFER #T4680

- NW1/4, NW1/4- 12.52 ACRES
- NE1/4, NW1/4- 29.30 ACRES
- SW1/4, NW1/4- 4.84 ACRES
- SE1/4, NW1/4- 38.34 ACRES

EXISTING WATER RIGHT ACRES
 LAKEVIEW WATER USERS CERTIFICATE #47469

- SW1/4, NE1/4- 24.9 ACRES
- SE1/4, NE1/4- 39.1 ACRES
- NW1/4, NE1/4- 10.9 ACRES

TOTAL ACRES- 159.9

HATCH LEGEND

- WATER RIGHTS FROM LAKEVIEW WATER USERS TRANSFER #T4680 TO REMAIN IN PLACE, 60.42 ACRES.
- WATER RIGHTS FROM LAKEVIEW WATER USERS TRANSFER #T4680 TO BE TRANSFERRED TO: 24.58 ACRES
- WATER RIGHTS FROM LAKEVIEW WATER USERS CERTIFICATE #47469 TO REMAIN IN PLACE, 63.4 ACRES.
- WATER RIGHTS FROM LAKEVIEW WATER USERS CERTIFICATE #47469 TO BE TRANSFERRED TO: 11.5 ACRES

NOTE:

LAKEVIEW WATER USERS TRANSFER #T4680: 60.42 ACRES TO REMAIN IN PLACE
 24.58 ACRES BEING TRANSFERRED AS SHOWN IN TRANSFER DIAGRAM.

LAKEVIEW WATER USERS CERTIFICATE #47469: 63.4 ACRES TO REMAIN IN PLACE
 11.5 ACRES BEING TRANSFERRED AS SHOWN IN TRANSFER DIAGRAM.

LEGEND

- SECTION LINE
- 1/4 SECTION LINE
- 1/16 SECTION LINE

T 7160

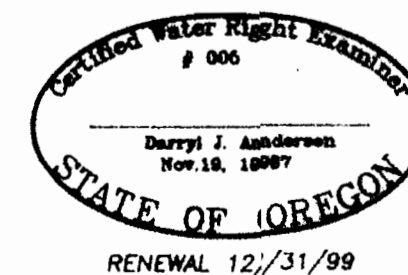

NOTE: PREPARATION OF THIS MAP IS FOR IDENTIFYING PROPOSED WATER RIGHTS ONLY. IT HAS NO INTENT TO PROVIDE LOCATIONS OR DIMENSIONS OF PROPERTY BOUNDARIES.

PREPARED FOR: ROBERT BOLTON HC 60 BOX 2390 LAKEVIEW, OR 97630 (541) 947-2552	
PREPARED BY: ANDERSON ENGINEERING & SURVEYING, INC. P.O. BOX 28 LAKEVIEW, OREGON 97630 (541) 947-4407 FAX 947-2321 P.O. BOX 419 REDMOND, OREGON 97756 (541) 923-4307 FAX 923-4308	
DATE: 1/8/98	DWG. FILE: 94020REV
JOB NO.: 94020	SHEET 1 OF 1

MAP REVISED TO SHOW
 CORRECTIONS TO MAP
 DATED MAY 4, 1994
 THAT ACCOMPANIED APPLICATION.
 REVISED: 1/8/98 BY R.F.C.