

BEFORE THE OFFICE OF ADMINISTRATIVE HEARINGS
STATE OF OREGON
for the
WATER RESOURCES DEPARTMENT

RECEIVED

JAN 09 2006

THE OFFICE OF
ADMINISTRATIVE HEARINGS

In the Matter of the Determination of the Relative Rights of the Waters of the
a Tributary of the Pacific Ocean

United States of America; Klamath Irrigation District; Klamath Drainage District; Tulelake Irrigation District; Klamath Basin Improvement District; Ady District Improvement Company; Enterprise Irrigation District; Malin Irrigation District; Midland District Improvement Co.; Pine Grove Irrigation District; Pioneer District Improvement Company; Poe Valley Improvement District; Shasta View Irrigation District; Sunnyside Irrigation District; Don Johnston & Son; Bradley S. Luscombe; Randy Walthall; Inter-County Title Company; Winema Hunting Lodge, Inc.; Van Brimmer Ditch Company; Plevna District Improvement Company; Collins Products, LLC;
Contestants

**STIPULATION TO RESOLVE
CONTESTS**

Case No. 251

Claim: 697

Contests: 3118, 3510¹, 3816, and 4240²

vs.

Richard W. Graham;
Claimant, and
Allan Klus; Irene Klus;
Claimants/Contestants.

Claimants Allan Klus and Irene Klus (hereinafter "Claimants"), Contestants the Klamath Project Water Users³ (hereinafter "KPWU"), Contestant the United States of America (hereinafter

¹ Don Vincent voluntarily withdrew from Contest 3510 on December 4, 2000. Berlva Pritchard voluntarily withdrew from contest 3510 on June 24, 2002. Klamath Hills District Improvement Company voluntarily withdrew from Contest 3510 on January 15, 2004.

² The Klamath Tribes voluntarily withdrew Contest 4240. See Klamath Tribes' Voluntary Withdrawal of Contest, dated August 3, 2004.

³ The Klamath Project Water Users consists of Klamath Irrigation District; Klamath Drainage District; Tulelake Irrigation District; Klamath Basin Improvement District; Ady District Improvement Company; Enterprise Irrigation District; Klamath Hills District Improvement Co.; Malin Irrigation District; Midland District Improvement Co.; Pine Grove Irrigation District; Pioneer District Improvement Company; Poe Valley

RECEIVED

JAN 05 2006

WATER RESOURCES DEPT
SALEM OREGON

“United States”) (collectively “Parties”) and the Oregon Water Resources Department (hereinafter “OWRD”) hereby agree and stipulate as follows:

A. STIPULATED FACTS

1. On January 31, 1991, Vina Kirk (“Ms. Kirk”) filed Claim 697 with OWRD.
2. The current claimants are Richard W. Graham (“Mr. Graham”) and Allan Klus and Irene Klus (the “Kluses”), who are all successors in interest to Ms. Kirk.
3. The property comprising the original, claimed place of use (the “Claim Lands”) is located in the SW/4SW/4 and the W/2SE/4SW/4 of Section 1, Township 34 South, Range 7½ East, Willamette Meridian and is intersected by a road known as “Crater Lake Highway 62.”
4. Mr. Graham succeeded to Ms. Kirk’s interest in that portion of the Claim Lands lying west of Crater Lake Highway 62 (the “Graham Lands”). The Kluses succeeded to Ms. Kirk’s interest in that portion of the Claim Lands lying east of Crater Lake Highway 62 (the “Klus Lands”).
5. On October 4, 1999, the Adjudicator issued his Preliminary Evaluation of Claim 697.
6. The following contests were filed to Claim 697 and/or the Preliminary Evaluation of Claim 697: Contest 3118 filed by Allan and Irene Klus; Contest 3510 filed by the Klamath Project Water Users; Contest 3816 filed by the United States; and Contest 4240 filed by the Klamath Tribes, which was voluntarily withdrawn on August 3, 2004.
7. On June 9, 2005, ALJ Daina Upite granted the United States’ Motion for Ruling on Legal Issues Against Claimant Richard W. Graham and recommended that the Adjudicator for the Klamath Basin General Stream Adjudication enter a Final Order denying Claim 697 as to the Graham Lands. ALJ Upite’s proposed order did not have any effect on or make any recommendations regarding Claim 697 as to the Klus Lands.

Improvement District; Shasta View Irrigation District; Sunnyside Irrigation District; Don Johnston & Son; Bradley S. Luscombe; Randy Walthall; Inter-County Title Company; Winema Hunting Lodge, Inc.; Van Brimmer Ditch Company; Plevna District Improvement Company; and Collins Products, LLC.

CASE NO. 251, CLAIM 697 – STIPULATION TO RESOLVE CONTESTS

RECEIVED

JAN 05 2006

WATER RESOURCES DEPT
SALEM OREGON

8. Claimant, Contestants, and OWRD agree that Contests 3118, 3510, and 3816 can be resolved without the need for further proceedings, pursuant to the terms set forth below.

B. TERMS AND PROVISIONS

1. The Parties and OWRD agree that Claim 697 should be approved by the Adjudicator as described below:
 - a. POINT OF DIVERSION LOCATION: NW ¼ NW ¼ , Section 26, Township 33 South, Range 7½ East, W.M., at a point 940 feet south and 960 feet east of the northwest corner of Section 26.
 - b. SOURCE: Fort Creek, tributary to the Wood River.
 - c. USE: Irrigation of 29.0 acres and incidental livestock watering. The parties other than OWRD agree that the maximum number of stock permitted for incidental watering of livestock under this right shall not exceed 60 head.
 - d. DIVERSION RATE: 0.58 cubic foot per second for irrigation. No additional diversion rate for livestock watering.
 - e. DUTY: 3.1 acre-feet/acre.
 - f. PERIOD OF USE: March 1 to October 16.
 - g. PRIORITY DATE: October 14, 1864.
 - h. PLACE OF USE:

SW ¼ SW ¼ 16.5 acres

SE ¼ SW ¼ 12.5 acres

Section 1

Township 34 South, Range 7 ½ East, W.M.

The places of use and point of diversion are shown more particularly on the map attached hereto as Exhibit A and incorporated herein by reference.

RECEIVED

JAN 05 2006
PAGE 3

2. The Parties and OWRD agree that pursuant to the terms and provisions of this Stipulation, Contests 3118, 3510, and 3816 have been satisfactorily resolved, and such resolution ends the need for further proceedings before the Administrative Law Judge on the contests to Claim 697.
3. Based on the Stipulation of the Parties and OWRD that Claim 697 and the Contests thereto can be resolved without the need for further proceedings, OWRD adjudication staff hereby recommends to the Adjudicator that Claim 697 be withdrawn from the Office of Administrative Hearings. OWRD adjudication staff further recommends that Claim 697 be approved in the Findings of Fact and Order of Determination issued by the Adjudicator in accordance with the terms of paragraph B.1., above.
4. If the Findings of Fact and Order of Determination issued by the Adjudicator for Claim 697 does not conform to the terms set forth in paragraph B.1., above, Claimants and Contestants reserve any rights they may have to file exceptions to the Findings of Fact and Order of Determination as to Claim 697 in the Circuit Court for Klamath County, and reserve any rights they may have to participate in any future proceedings authorized by law concerning Claim 697.
5. The Parties agree that this Stipulation has been reached through good faith negotiations for the purpose of resolving legal disputes, including pending litigation. The Parties agree that no offers and/or compromises made in the course thereof shall be construed as admissions against interest. The Parties agree that this Stipulation shall not be offered as evidence or treated as an admission regarding any matter herein and may not be used in proceedings on any other claim or contest whatsoever, except that the Stipulation may be used in any future proceeding to interpret and/or enforce the terms of this Stipulation. Further, the parties agree

RECEIVED

JAN 05 2006
PAGE 4

WATER RESOURCES DEPT
SALEM OREGON

that neither the Stipulation nor any of its terms shall be used to establish precedent with respect to any other claim or contest in the Klamath Basin Water Rights Adjudication.

6. This Stipulation shall be binding upon and shall inure to the benefit of the Parties and their respective heirs, executors, administrators, trustors, trustees, beneficiaries, predecessors, successors, affiliated and related entities, officers, directors, principals, agents, employees, assigns, representatives and all persons, firms, associations, and/or corporations connected with them.
7. Each Party to this Stipulation represents, warrants, and agrees that the person who executed this Stipulation on its behalf has the full right and authority to enter into this Stipulation on behalf of that party and bind that party to the terms of the Stipulation.
8. The terms, provisions, conditions, and covenants of this Stipulation are not severable, except, if any term, provision, conditions, or covenant of this Stipulation is held by a court of competent jurisdiction to be invalid, void, or unenforceable, the remainder of the terms, provisions, conditions, and covenants shall remain in full force and effect and shall in no way be affected, impaired, or invalidated.
9. This Stipulation may be executed in several counterparts and all documents so executed shall constitute one Stipulation, binding on the Parties, notwithstanding that the Parties did not sign the same original or the same counterparts. Delivery of an executed signature page to this Stipulation by facsimile transmission shall be as effective as delivery of an original signed counterpart of this Stipulation.
10. This Stipulation comprises the entire agreement between the Parties concerning the subject matter hereof, and no promise, inducement, or representation other than herein set forth has been made, offered, and/or agreed upon, and the terms of this Stipulation shall be binding and enforceable upon the Parties and not mere recitals.

RECEIVED

JAN 05 2006

WATER RESOURCES DEPT
SALEM, OREGON

11. The Parties and OWRD agree to each bear their own costs and attorney fees.
12. This Stipulation shall be effective as of the date of the last signature hereto.

STIPULATED, AGREED AND APPROVED:

FOR CLAIMANTS/CONTESTANTS ALLAN KLUS AND IRENE KLUS

DATED: October 21, 2005
~~November~~

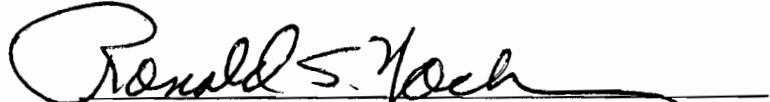

RONALD S. YOCKIM
Attorney at Law
P.O. Box 2456
Roseburg, OR 97470
Phone: 541-957-5900
Fax: 541-957-5923
E-mail: ryockim@mcsi.net



ALLAN KLUS



IRENE KLUS

RECEIVED

JAN 05, 2006
PAGE 8

WATER RESOURCES DEPT
SALEM OREGON

FOR CONTESTANT, THE UNITED STATES OF AMERICA:

DATED: December 2, 2005

SUE ELLEN WOOLDRIDGE
Assistant Attorney General



THOMAS K. SNODGRASS
United States Department of Justice
Environment & Natural Resources Division
General Litigation Section
999 18th Street, North Tower, Suite 945
Denver, CO 80202
Telephone: 303/312-7326
Telefax: 303-312-7379
email: thomas.snodgrass@usdoj.gov
email: klamathcase.enrd@usdoj.gov



BARBARA SCOTT-BRIER
Special Attorney
United States Department of Justice
Environment & Natural Resources Division
500 NE Multnomah, Suite 607
Portland, OR 97232
Telephone: 503/231-2139
Telefax: 503/231-2166

ATTORNEYS FOR THE UNITED
STATES OF AMERICA

RECEIVED

JAN 05 2006

WATER RESOURCES DEPT
SALEM OREGON

FOR CONTESTANT, THE KLAMATH PROJECT WATER USERS:

DATED: ^{December} November 15, 2005



ANDREW M. HITCHINGS
Attorneys for Tulelake Irrigation District and on behalf of
the Klamath Project Water Users
Somach, Simmons & Dunn
Hall of Justice Building
813 Sixth Street, Third Floor
Sacramento, CA 95814-2403
Phone: 916-446-7979
Fax: 916-446-8199
E-mail: ahitchings@lawssd.com

RECEIVED
JAN 05 2006
WATER RESOURCES DEPT
SALEM OREGON

FOR THE OREGON WATER RESOURCES DEPARTMENT:

HARDY MYERS
Attorney General

DATED: January 4, 2006

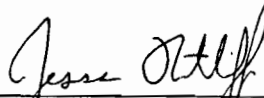

JESSE D. RATCLIFFE
STEPHEN EA SANDERS
Assistant Attorneys General
Oregon Department of Justice
1162 Court Street NE
Salem, Oregon 97301-4096
Phone: 503-947-4500
Fax: 503-378-3802
E-mail: jesse.d.ratcliffe@doj.state.or.us
steve.sanders@doj.state.or.us

DATED: January 4, 2006



MICHAEL J. REYNOLDS
Oregon Water Resources Department
725 Summer St. NE, Suite A
Salem, Oregon 97301-1271
Phone: 503-986-0820
Fax: 503-986-0901
E-mail: mike.j.reynolds@state.or.us

RECEIVED

JAN 05 2006

WATER RESOURCES DEPT
SALEM OREGON

RECEIVED

NOV 05 1999

FINAL PROOF MAP FOR KLAMATH ADJUDICATION CLAIM #697 FOR ALLAN KLUS

WATER RESOURCES DEPT.
SALEM, OREGON

LOCATED IN THE S½SW¼, SEC. 1, T.34S., R.7 1/2E., W.M.
KLAMATH COUNTY, OREGON



SCALE: 1" = 1320'

THIS MAP IS FOR THE PURPOSE OF IDENTIFYING THE LOCATION OF THE WATER RIGHT ONLY AND HAS NO INTENT TO PROVIDE DIMENSIONS OR LOCATION OF PROPERTY LINES.

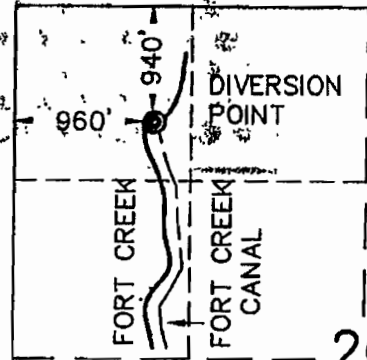

26

T.33S., R.07 1/2E., W.M.



IRRIGATED AREA

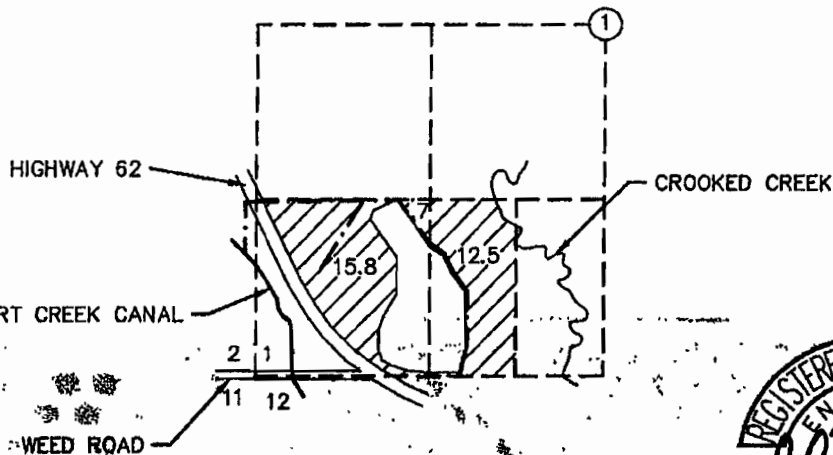

KLAMATH ADJUDICATION
CLAIM # **697** PAGE # **67**

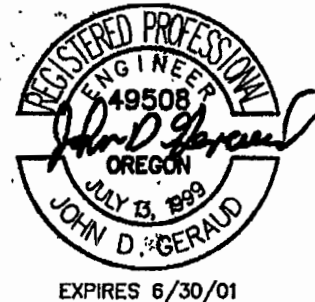

Engineers ▲ Planners ▲ Surveyors

2950 Shasta Way • Klamath Falls, Oregon 97603 • (541) 884-4666 • FAX (541) 884-5335

October 29, 1999

Klamath Falls, Oregon 97603 • (541) 884-4666 • FAX (541) 884-5335

JOB No. 2149-01

RECEIVED

JAN 05 2000

CERTIFICATE OF SERVICE

I hereby certify that on the 4th day of January 2006, I served the within STIPULATION TO RESOLVE CONTESTS on the parties hereto by e-mail, and by regular first-class mail (with a courtesy copy by e-mail where an e-mail address is listed below), a true, and exact and full copy thereof to:

VIA STATE SHUTTLE MAIL

Dwight W. French / Teri Hranac
Oregon Water Resources Department
725 Summer Street NE, Suite A
Salem, OR 97301-1271
dwight.w.french@wrд.state.or.us
teri.k.hranac@wrд.state.or.us

Paul S. Simmons / Andrew M. Hitchings
Somach, Simmons & Dunn
Hall of Justice Building
813 Sixth Street, Third Floor
Sacramento, CA 95814-2403
psimmons@lawssd.com
ahitchings@lawssd.com

William M. Ganong
Attorney at Law
514 Walnut Street
Klamath Falls, OR 97601
wganong@aol.com

Ronald S. Yockim
Attorney at Law
548 SE Jackson, Suite 7
P.O. Box 2456
Roseburg, OR 97470
ryockim@mcsi.net

Thomas K. Snodgrass
United States Department of Justice
Environment & Natural Resources Div.
999 18th Street, Suite 945, North Tower
Denver, CO 80202
thomas.snodgrass@usdoj.gov

Barbara Scott-Brier
U.S. Department of Justice
Environment & Natural Resources Div.
500 NE Multnomah Street, Suite 607
Portland, OR 97232

Richard W. Graham
475 Kaer Ave.
Red Bluff, CA 96080

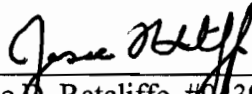

Jesse D. Ratcliffe, #01394
Stephen E.A. Sanders, #85321
Assistant Attorneys General

RECEIVED

JAN 05 2006

WATER RESOURCES DEPT
SALEM OREGON