



N  
Scale  
1" = 880'

R-88149

RECEIVED  
NOV 16 2015  
OWPRD

IMPORTANT !!  
This Map for Assessment  
and Taxation Purposes  
ONLY

9.4.19  
POLK COUNTY

9.4.19

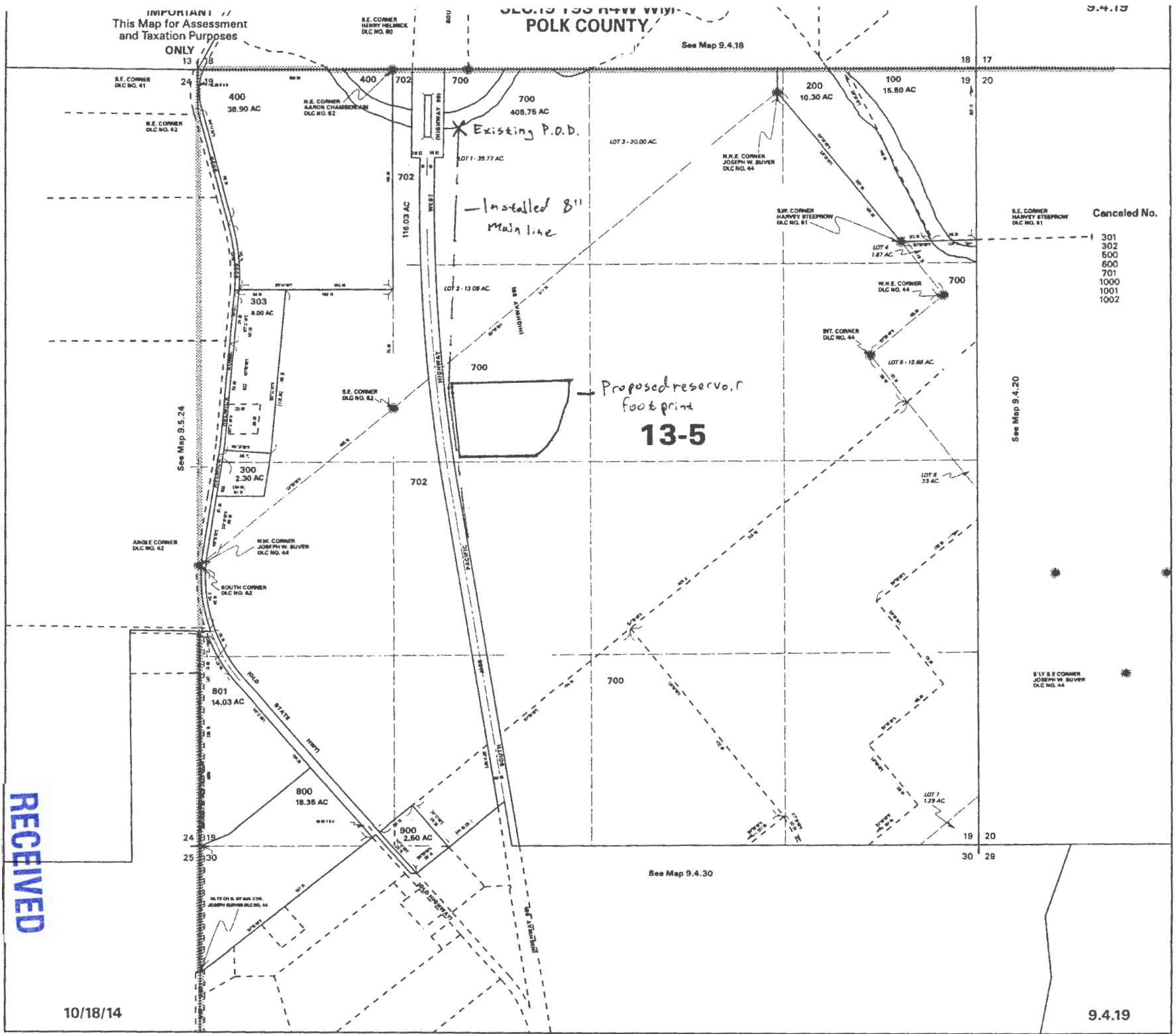

- Canceled No.
- 301
  - 302
  - 500
  - 600
  - 701
  - 1000
  - 1001
  - 1002

10/18/14

9.4.19

R-981408

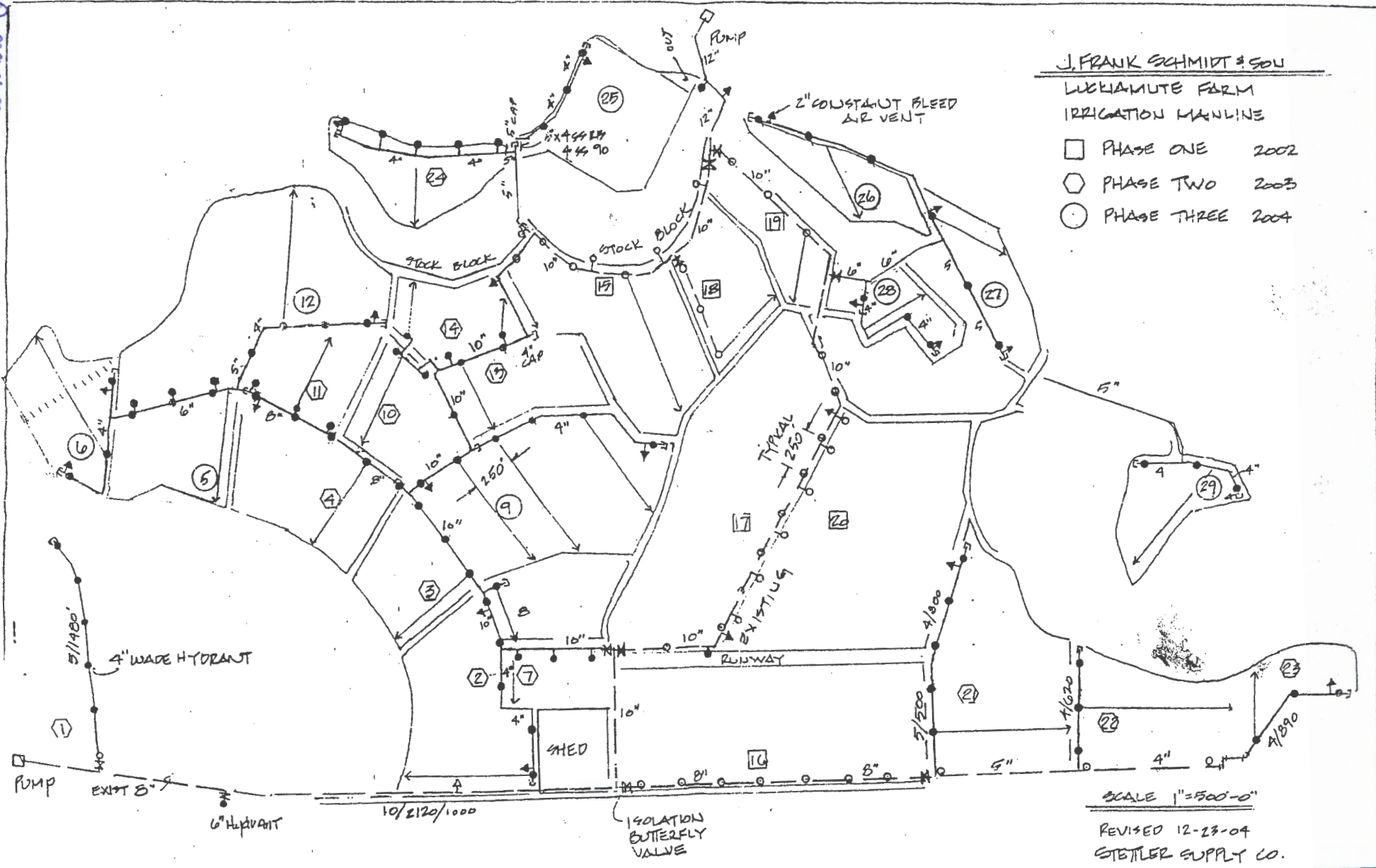

J. FRANK SCHMIDT & SON

LICKIAMUTE FARM  
IRRIGATION MAINLINE

- PHASE ONE 2002
- ⬡ PHASE TWO 2003
- PHASE THREE 2004

SCALE 1"=500'-0"

REVISED 12-23-04  
STETTLER SUPPLY CO.

RECEIVED  
NOV 16 2015  
OWRD

In the image below the shaded polygon represents the proposed reservoir footprint. Based on a GPS survey of the outside perimeter the total reservoir footprint is 25.2 acres.



In the drawing below the dam is shown at its tallest section.

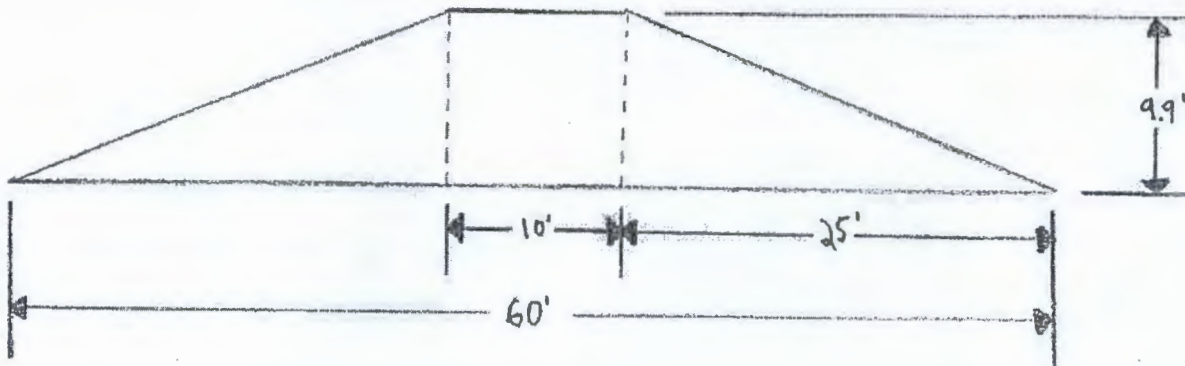

**RECEIVED**  
**NOV 16 2015**  
**OWRD**

R-88149

R-08140



75 100 150

1=400

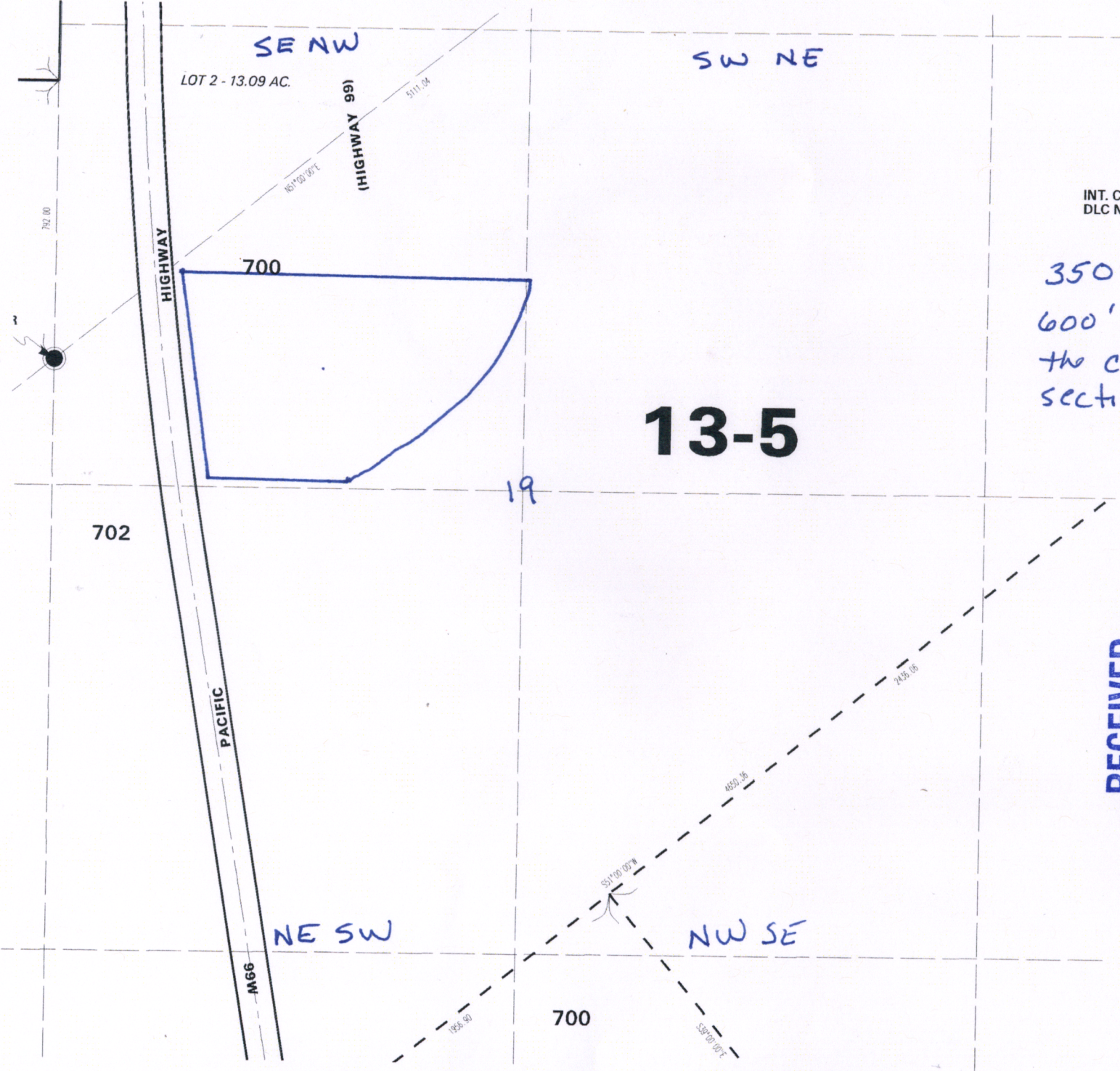

350' N and  
600' W of  
the center of  
section 19.

RECEIVED  
NOV 16 2015  
OWRD