



# Oregon

John A. Kitzhaber, MD, Governor

Water Resources Department  
North Mall Office Building  
725 Summer Street NE, Suite A  
Salem, OR 97301-1271  
503-986-0900  
FAX 503-986-0904

## MEMORANDUM

**TO:** Water Resources Commission

**FROM:** Phillip C. Ward, Director

**DATE:** Agenda Item E-1, March 6, 2014

### Deschutes Basin Ground Water Mitigation Program Annual Report

#### I. Issue Statement

This report, required by OAR 690-505-0500(3) and OAR 690-521-0600, provides the 2012 annual evaluation of the Deschutes Ground Water Mitigation Rules, OAR Chapter 690, Division 505; and the Deschutes Basin Mitigation Bank and Mitigation Credit Rules, OAR Chapter 690, Division 521.

#### II. Background

On September 13, 2002, the Commission adopted the Deschutes Ground Water Mitigation Rules and the Deschutes Basin Mitigation Bank and Mitigation Credit Rules. These rules implement Senate Bill 1033 (1995), HB 2184 (2001), HB 3494 (2005), and most recently HB 3623 (2011). The rules provide for mitigation of impacts to scenic waterway flows and senior water rights, while allowing additional appropriations of groundwater in the Deschutes Ground Water Study Area (See Attachment 1).

The Deschutes Ground Water Mitigation Rules allow groundwater users to provide mitigation through an individual mitigation project, a mitigation credit holder, or an approved mitigation bank. The Deschutes Basin Mitigation Bank and Mitigation Credit Rules authorize the establishment of a mitigation credit system and mitigation banks to help facilitate transactions among holders of mitigation credits and persons interested in acquiring mitigation credits.

On June 4, 2010, the Commission adopted the Deschutes Basin Water Management Rules (OAR 690-522), which operate in conjunction with the Deschutes Ground Water Mitigation Rules and the Deschutes Basin Mitigation Bank and Mitigation Credit Rules. The Deschutes Basin Water Management Rules changed how the Department counts new groundwater permit applications under the allocation cap and allowed some unused mitigation credits to be reassigned. The rules also clarified how municipal and quasi-municipal permit holders can provide mitigation under incremental development plans and allowed additional flexibility to use "offsets" and to move mitigation credits between permits.

During the 2011 Legislative session, House Bill 3623 extended the January 2, 2014 sunset on the mitigation program to January 2, 2029. The Department is required to report to the Legislature every five years on the outcomes of the Mitigation Program. The first report to the Legislature is due in 2015.

### **III. Discussion**

Under the Deschutes Ground Water Mitigation Rules, the Department is required to annually report on and evaluate the Mitigation Program, including the implementation and management of mitigation credits allocated through existing mitigation banks. The mitigation program in the Deschutes Ground Water Study Area continues to address new and changing water needs, while protecting scenic waterway flows. Mitigation program activities are summarized below.

#### **A. New Groundwater Appropriations and Mitigation Activities**

**Permits Issued:** Since adoption of the mitigation rules in September 2002, a total of 99 groundwater permits, with associated mitigation, have been issued. Four of these permits have been cancelled, one of which was cancelled 2012. Four permits have been issued certificates. Six new permits that were issued in 2012 as described in Attachment 2.

**Applications with Final Orders:** By the end of 2012, 22 groundwater permit applications had been processed to the final order stage. Permits will be issued when the required mitigation or any other required information (such as permit recording fees) is provided.

**Pending Applications:** There are another 22 pending applications for groundwater use in the Deschutes Ground Water Study Area. Four of the applications with a Proposed Final Order have been protested. Attachment 3 provides a breakdown of the pending applications and their status.

**Allocation Cap Summary:** The amount of new groundwater use that can be approved under the program is limited to a total of 200 cubic feet per second (cfs). As of the end of 2012, 141.5 cfs of water had been allocated under new permits and approved final orders. This leaves 58.5 cfs that can still be approved under the 200 cfs allocation cap. At the end of 2012, there was an additional 57.6 cfs in pending applications which, if approved, would have left 0.9 cfs available under the 200 cfs cap.<sup>1</sup> This included adjustments made to the amount available under the 200 cfs cap based upon the rule changes adopted by the Commission in 2010 (Division 522 – Deschutes Basin Water Management).

---

<sup>1</sup> Between the end of 2012 and October 15, 2013, the amount of water tied up in pending applications was reduced to approximately 37 cfs. If approved, this would leave approximately 27 cfs available under the 200 cfs cap. The increase in the amount of water available for additional appropriation under the cap is primarily due to the expiration of several final orders, withdrawal and denial of a few applications.

Incremental Development Plans: A total of 12 permits with incremental development plans have been approved, including one new permit issued in 2012. By rule, the Department may allow a municipal or quasi-municipal applicant to supply mitigation over a period of time, incrementally, as the water use is developed rather than requiring that all mitigation be provided before the permit is issued. The amount of mitigation provided must coincide with the rate of development within each increment. Each permit holder must have an incremental development plan on file with the Department and may amend that plan with prior approval by the Department. The Division 522 (Deschutes Basin Water Management rules), clarified how municipal and quasi-municipal permit holders may grow into each increment. Municipal and quasi-municipal permit holders must include the annual volume of water used and the source of mitigation used as part of their annual reporting requirements. A summary of water use for municipal and quasi-municipal permit holders is provided in Attachment 4.

B. Mitigation Activity

Mitigation for the active groundwater permits and certificates issued by the Department under the Mitigation Program is being provided through permanent instream transfers and temporary instream leases.

- The majority of mitigation water continues to be primarily from instream transfers. Mitigation is considered used when assigned to a groundwater application or permit. Attachment 5 provides a summary of the amount of permanent and temporary mitigation provided in 2012 and the amount of mitigation used in 2012.
- The amount of mitigation water used each year is less than the full amount of mitigation required by permits and certificates primarily because municipal and quasi-municipal permit holders can provide mitigation incrementally. In 2012, the full mitigation obligation of all permits/certificates was 9530.3 AF, of which 8124.2 AF (85%) was associated with municipal and quasi-municipal permits. However, in 2012, approximately 615.9 AF of mitigation water was needed to meet consumptive use by municipal and quasi-municipal water users under the Mitigation Program. The municipal and quasi-municipal permit holders provided 1312.5 AF of mitigation meaning that these permit holders are not only meeting the requirements of their incremental development plans but are also providing mitigation in advance of actual need. Attachment 6 highlights the amount of mitigation required and the amount of mitigation provided for all permits and certificates.

Each January, the Deschutes River Conservancy (DRC) Mitigation Bank submits a report detailing all of the credit transactions and activities for the preceding calendar year. Generally, the DRC Mitigation Bank has operated with temporary mitigation credits based on instream leases. In all cases, the DRC Mitigation Bank has maintained sufficient "reserve" credits to cover temporary mitigation credits used by groundwater permit holders in each zone of impact. In 2012, the DRC Mitigation Bank completed 30 mitigation credit

transactions with groundwater permit holders and permit applicants. To date, no mitigation credit transactions have been completed by the Deschutes Irrigation Mitigation Bank, chartered by the Commission in 2006.

In 2012, there were 52 active mitigation projects, 21 were instream leases (submitted by the DRC Mitigation Bank) and 31 were permanent instream transfers (submitted by other parties). Attachment 7 provides a summary of groundwater permit and mitigation activity for 2012 by zone of impact and demonstrates that more mitigation (including unused mitigation) is in place than required in each of the zones of impact in which new groundwater permits have been issued. As of year-end 2012, there were 12 permits that completely switched from temporary mitigation credits to permanent credits. Four other permits partially switched to permanent mitigation credits.

As of year-end 2012, six of the permits issued with a mitigation obligation totaling 68.1 AF failed to provide mitigation. Each groundwater permit holder is required by rule and by permit condition to provide mitigation for the life of the groundwater permit, and subsequent certificate.

- One of these permits (18.0 AF) had no mitigation in place from 2007 through 2011 and was cancelled by the Department in 2012, following denial of an extension request and expiration of the permit completion deadline. In this case, the permit holder had not been irrigating nor had the well been drilled.
- For the 5 remaining permits (50.1 AF) that have not provided mitigation, the Department will continue to work with the permit to ensure that mitigation is secured. In the meantime, permit holders will not be allowed to irrigate, and if compliance does not occur, the Department will pursue cancellation.

#### C. Mitigation and the Five-Year Deadline

Upon issuing a final order approving a new groundwater use under the Deschutes Mitigation Program the applicant has five years to provide the required mitigation. Once mitigation obligations are met, the Department issues the groundwater permit and the new permit holder may begin using water. Groundwater use may not begin until a permit is issued. If mitigation is not provided within the five-year time line, the final order expires. As of October 15, 2013, 18 final orders had expired resulting in 9.6 cfs being added back into the 200 cfs allocation cap on new groundwater use.

#### D. Mitigation and Streamflow Monitoring

To monitor the impact of new groundwater permits and mitigation on scenic waterway flows and instream water right flows, the Department developed a streamflow modeling program. The program uses historic streamflow data and modifies these flows based on the estimated, steady-state, hydrologic impacts of credits and debits evaluated individually by the Department's

hydrogeologists and hydrologists. The streamflow model was constructed using a base period of flows from 1966 to 1995 at selected gaging stations around the basin. This base period represents stream flows during a period of time after the dams in the basin were constructed and before the Scenic Waterway Act was amended to include consideration of groundwater impacts.

Analysis of the 2012 data demonstrates that on an annual basis the change in percent of time the instream flow requirements are met at the evaluation points is predominantly positive, ranging from -0.15 to +0.42% (see Attachment 8). Similarly, the overall annual change in streamflow is positive above Lake Billy Chinook to slightly negative below, ranging from -3.24 to +11.25 cfs respectively.

Consistent with previous evaluations performed on the mitigation program, the absolute change in streamflow on a seasonal basis continues to be negative at all evaluation points during the non-irrigation season and positive at all evaluation points during the summer. This is expected given the timing difference between the effects of new groundwater withdrawals and mitigation projects (i.e. instream transfers and leases) on streamflow. New groundwater uses produce a decrease in streamflow that is uniformly distributed over the year while mitigation projects generally increase streamflow only during the irrigation season (Attachment 9).

The seasonal changes in percent of time the instream flow requirements (ISFR) are met at each evaluation site follows the seasonal impacts in terms of absolute streamflow. During the non-irrigation season, the impact to the percent of time the ISFR is met is generally negative while the percent of the impact during the irrigation season is predominantly positive. The relative change in percent time the ISFR is met varies by month and site depending on how close the historical flows were to the ISFR prior to the mitigation program. If the historical flows were close to the ISFR for a given evaluation site, then a small change in flows can relate to a relatively large change in percent of time the ISFR is met (see summer flows for the Deschutes River at Lower Bridge, Attachment 8). The opposite is true if the historical flows differed greatly from the ISFR (see summer flows for the Deschutes River at Lake Billy Chinook, Attachment 8).

#### **IV. Summary**

The Department continues to implement the Deschutes Ground Water Mitigation Rules and Deschutes Basin Mitigation Bank and Mitigation Credit Rules. Groundwater permit applications and mitigation projects are moving through the required processes. The program is producing positive benefits as more mitigation water has been approved and protected instream than required for the 95 groundwater permits and certificates issued. Model results through 2012 suggest that instream flows have improved compared to base line conditions on an annual basis. Seasonally, the mitigation effects on the instream requirements are negative during the non-irrigation season and positive during the irrigation season. These differences in seasonal effects are inherent in the mitigation program and will continue into the future. The relative impact to the percent of time the ISFR are met on a monthly basis depends on how close the ISFR is to the pre-mitigation streamflow and varies by each evaluation site.

## **V. Alternatives**

The Commission may consider the following options:

1. Accept report.
2. Direct staff to report back after further review of the 2012 program.

## **VI. Staff Recommendations**

The Department recommends Alternative 1.

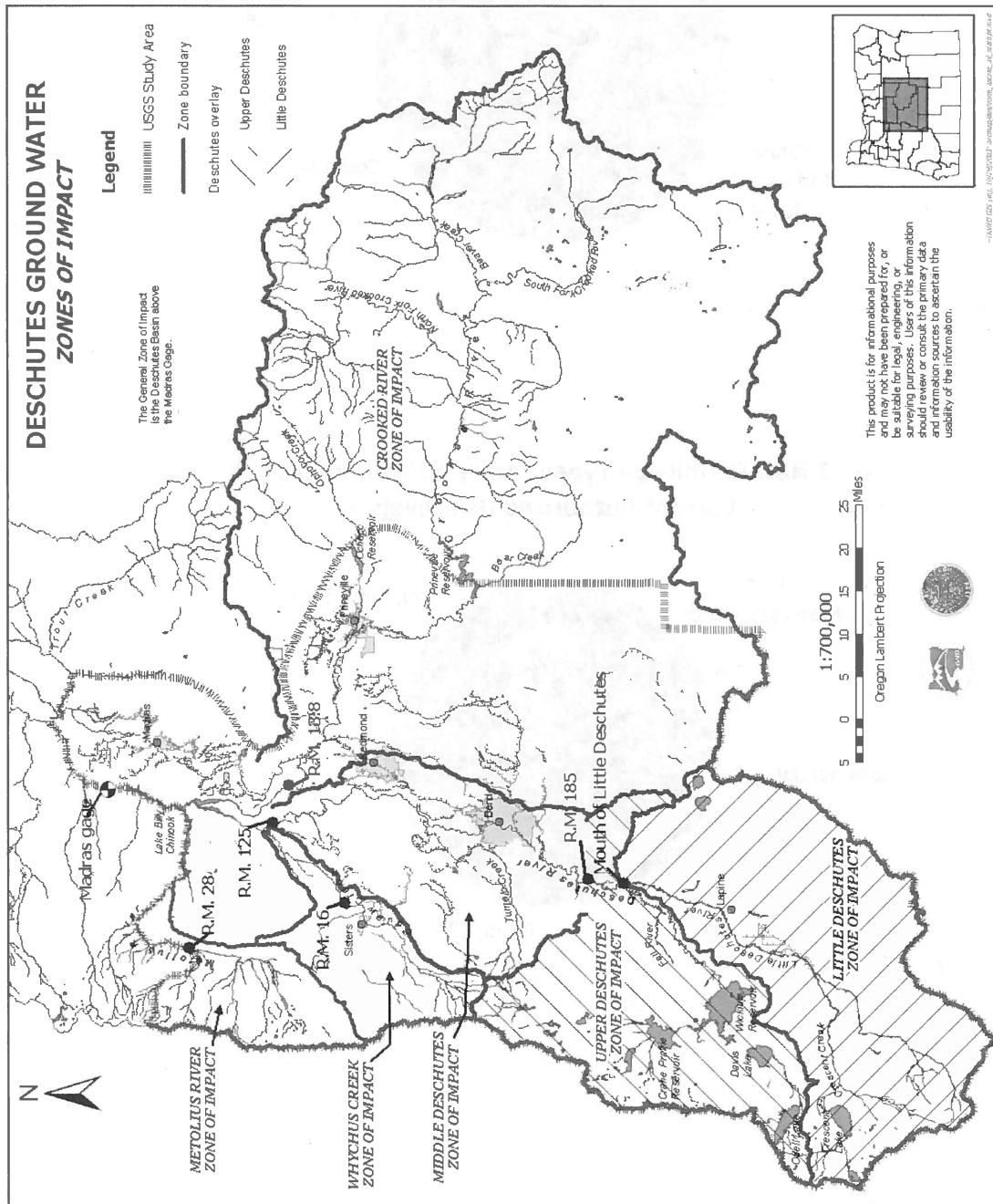
Attachments:

1. Deschutes Ground Water Study Area Zone of Impact Map
2. New Permits Issued in 2012
3. Status of Pending Groundwater Applications
4. Summary of Permits with Incremental Development Plans
5. Mitigation Water Established and Used in 2012
6. Summary of Mitigation Obligations and Use Levels for 2012
7. Summary of Mitigation Activity for 2012
8. Summary of streamflow for Water Year Ending September 2012
9. Assessing the Impact of Mitigation on Stream Flow in the Deschutes Basin

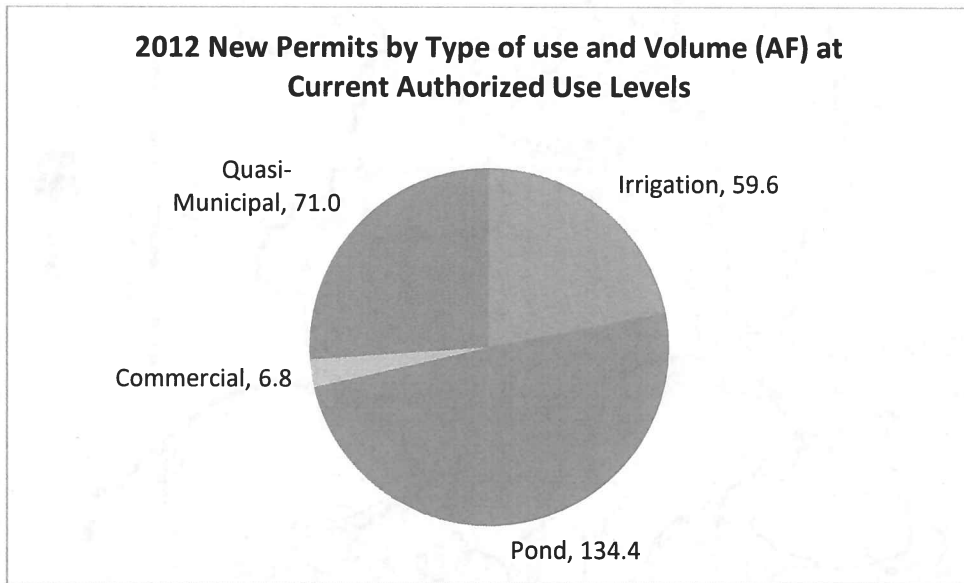
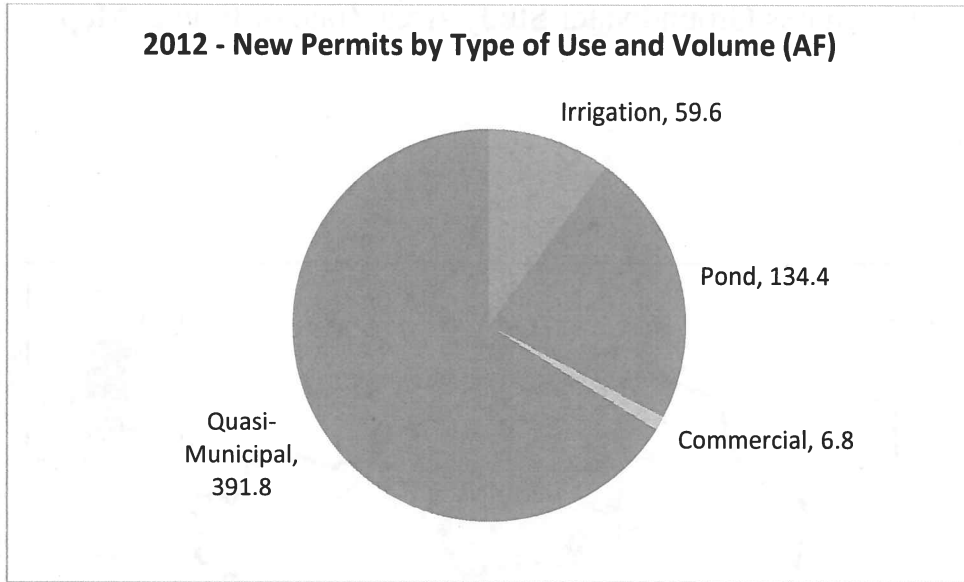
Dwight French  
503-986-0819

Laura Wilke  
503-986-0884

# Deschutes Groundwater Study Area Zone of Impact Map

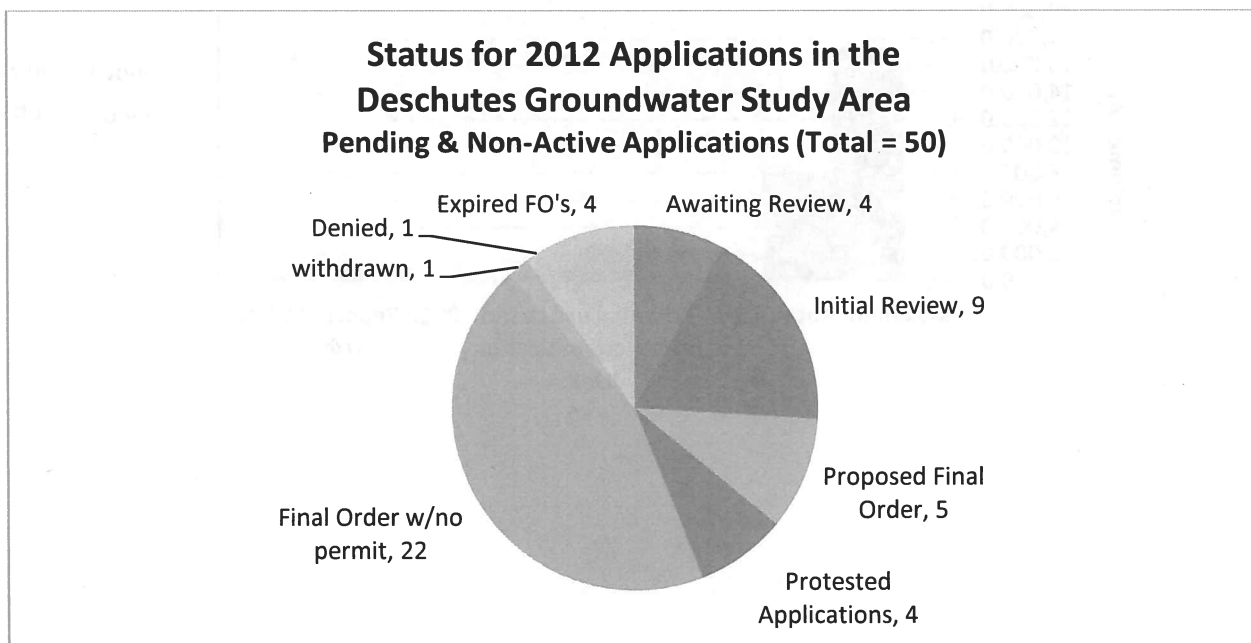
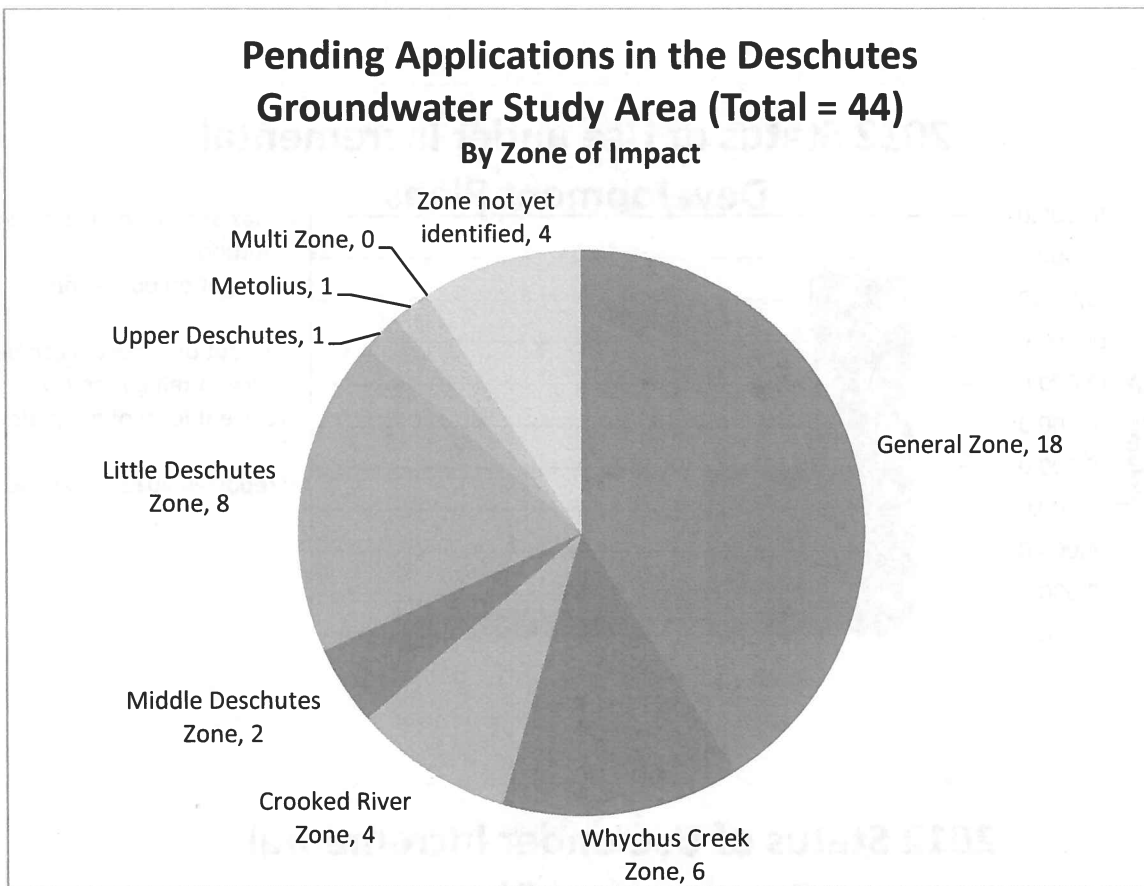


### New Permits Issued in 2012

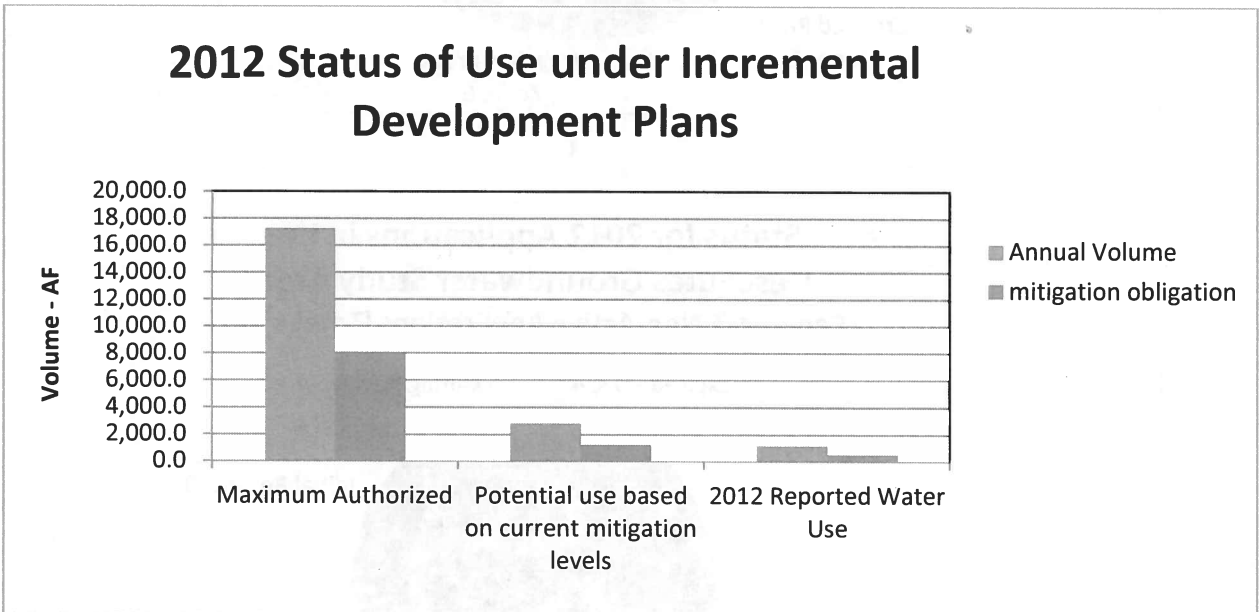
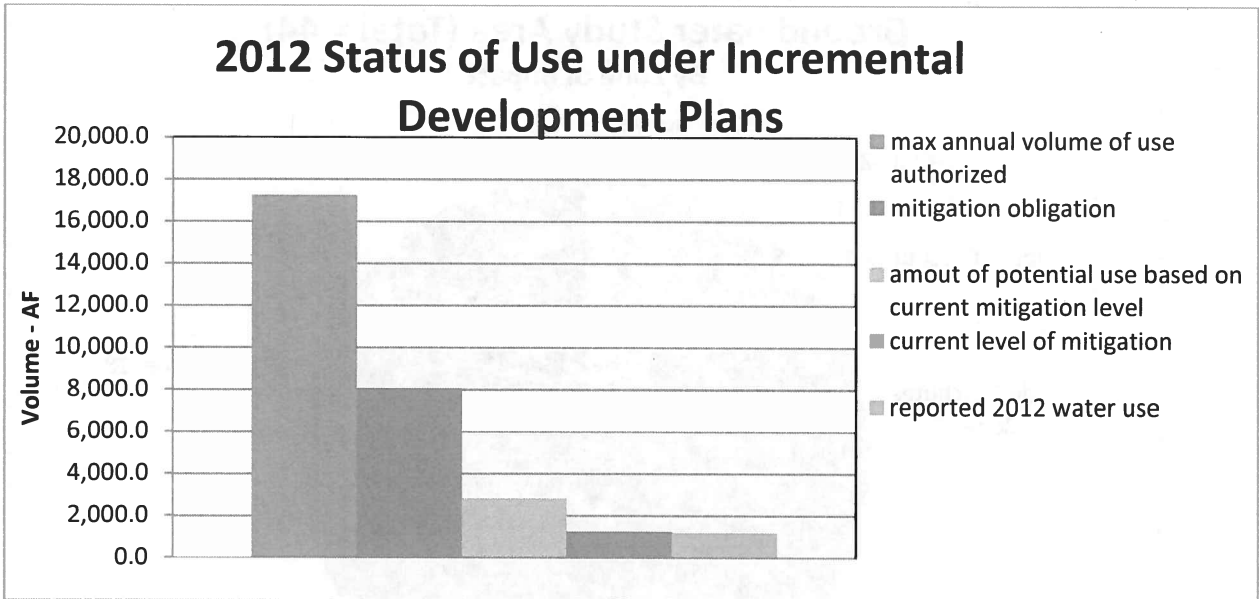




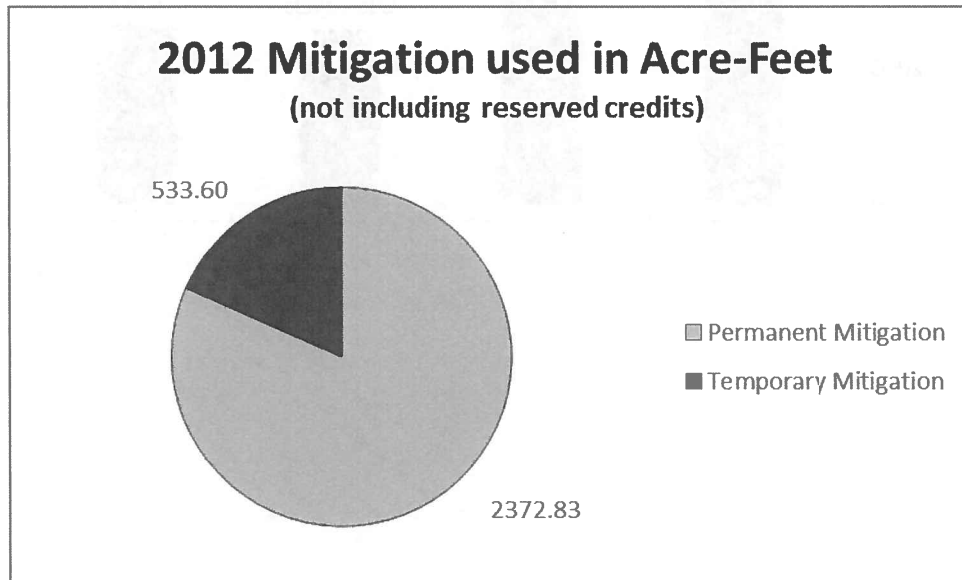
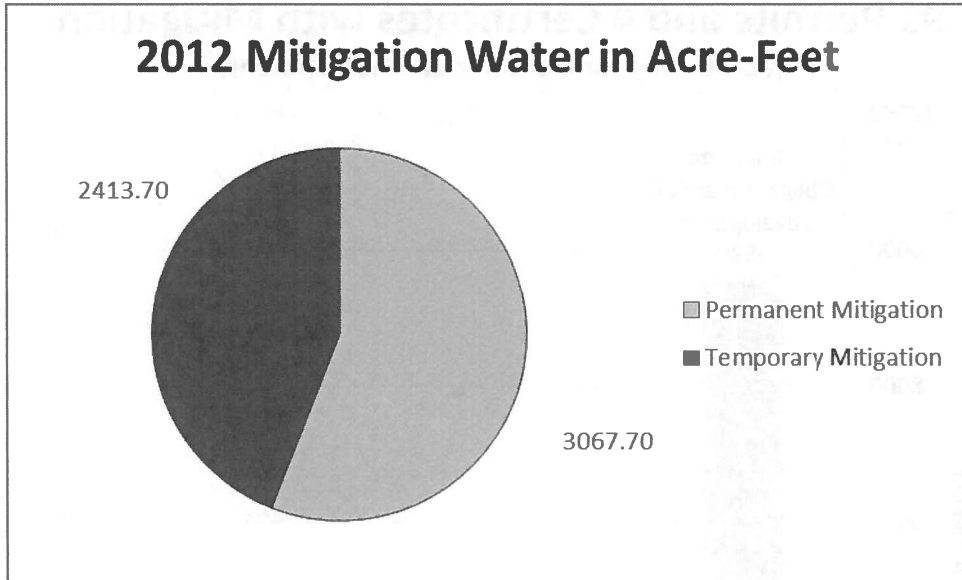
Status of Pending Groundwater Applications as of 12/31/2012



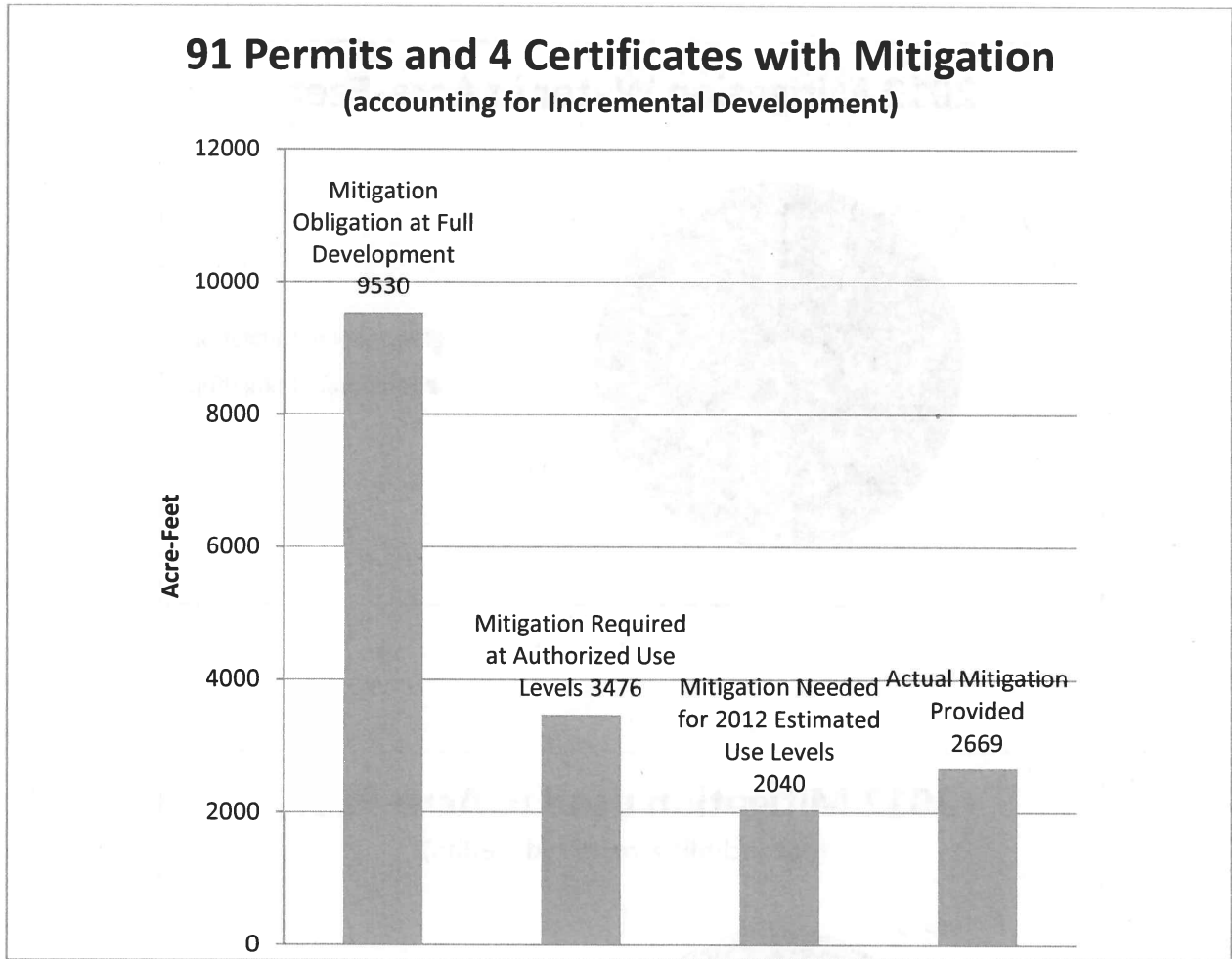
Summary of Permits with Incremental Development Plans



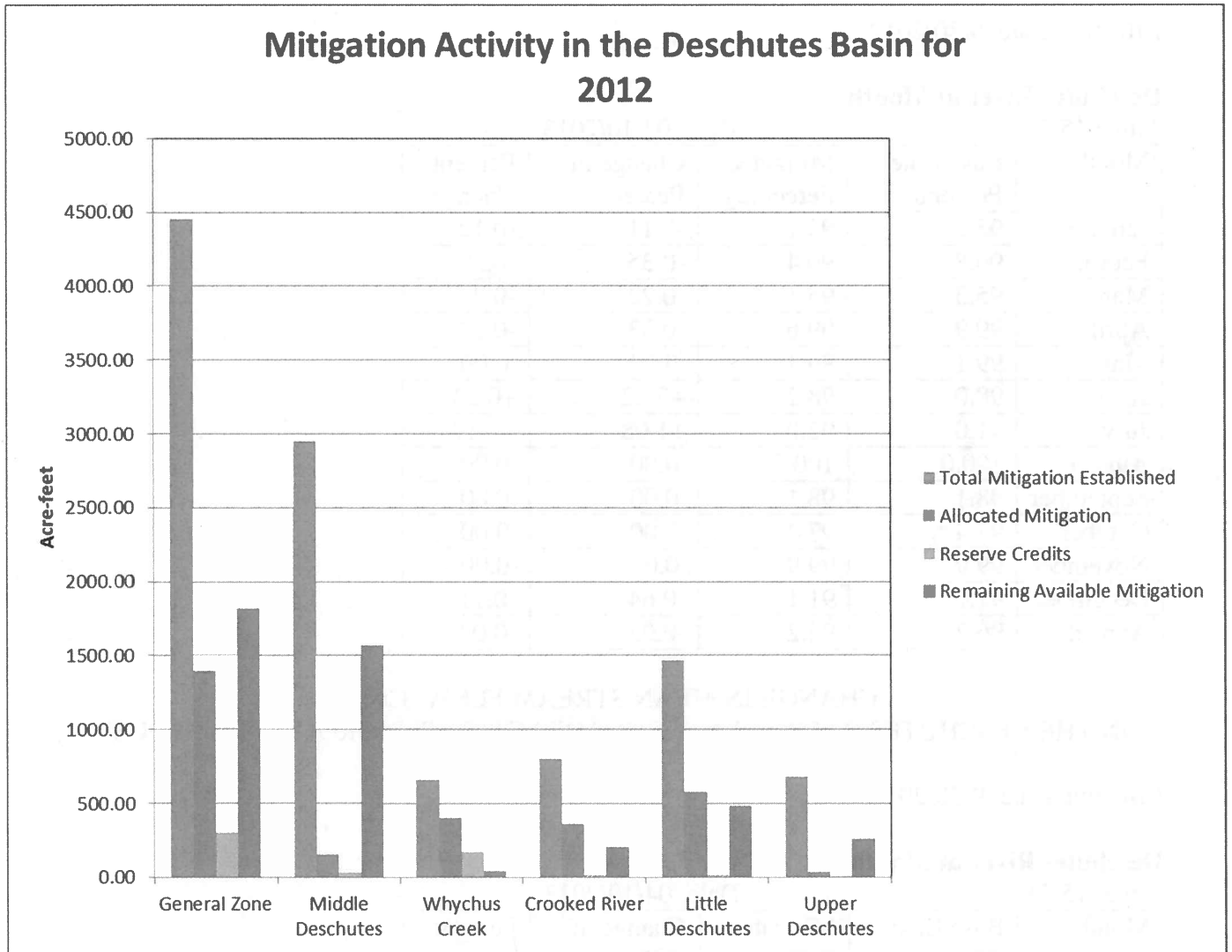
### Mitigation Water Established and Used in 2012



### Summary of Mitigation Obligations and Use Levels for 2012



Summary of Mitigation Activity for 2012



**CHANGE IN PERCENT OF TIME INSTREAM REQUIREMENTS ARE MET  
IN THE DESCHUTES BASIN AS A RESULT OF MITIGATED GROUNDWATER USE**

Effective Date: 9/30/2012

**Deschutes River at Mouth**

Time: 15:51

Date: 04/10/2013

Month	Base Line Percentage	Mitigated Percentage	Change in Percent	Percent Change
January	93.2	93.1	-0.11	-0.12
February	90.8	90.4	-0.35	-0.39
March	95.3	95.1	-0.22	-0.23
April	99.9	99.6	-0.33	-0.34
May	99.1	99.1	0.00	0.00
June	98.0	98.2	+0.22	+0.23
July	91.0	92.0	+1.08	+1.17
August	100.0	100.0	0.00	0.00
September	98.1	98.1	0.00	0.00
October	97.4	97.4	0.00	0.00
November	99.9	99.9	0.00	0.00
December	91.7	91.1	-0.64	-0.71
Annual	96.2	96.2	-0.03	-0.03

**CHANGE IN MEAN STREAM FLOW (CFS)  
IN THE DESCHUTES BASIN AS A RESULT OF MITIGATED GROUNDWATER USE**

Effective Date: 9/30/2012

**Deschutes River at Mouth**

Time: 15:51

Date: 04/10/2013

Month	Base Line CFS	Mitigated CFS	Change in CFS	Percent Change
January	6910.0	6890.0	-19.5	-0.28
February	7080.0	7060.0	-19.5	-0.28
March	7250.0	7230.0	-19.5	-0.27
April	6640.0	6630.0	-9.43	-0.14
May	5800.0	5810.0	+3.75	+0.06
June	5200.0	5210.0	+14.1	+0.27
July	4590.0	4610.0	+18.6	+0.40
August	4380.0	4400.0	+17.6	+0.40
September	4430.0	4440.0	+11.4	+0.26
October	4710.0	4710.0	+0.536	+0.01
November	5390.0	5370.0	-18.8	-0.35
December	6190.0	6170.0	-19.5	-0.32
Annual	5710.0	5700.0	-3.24	-0.06

**CHANGE IN PERCENT OF TIME INSTREAM REQUIREMENTS ARE MET  
IN THE DESCHUTES BASIN AS A RESULT OF MITIGATED GROUNDWATER USE**

Effective Date: 9/30/2012

**Deschutes River below Pelton Dam**

Time: 15:47

Date: 04/10/2013

Month	Base Line Percentage	Mitigated Percentage	Change in Percent	Percent Change
January	64.7	64.1	-0.64	-1.01
February	63.0	62.2	-0.83	-1.33
March	67.8	66.9	-0.97	-1.45
April	71.4	70.7	-0.78	-1.10
May	58.8	60.0	+1.18	+1.97
June	55.6	57.4	+1.89	+3.29
July	41.0	42.7	+1.72	+4.03
August	98.2	99.0	+0.86	+0.87
September	66.8	67.4	+0.67	+0.99
October	81.1	81.1	0.00	0.00
November	97.2	97.2	0.00	0.00
December	66.1	65.5	-0.64	-0.99
Annual	69.3	69.5	+0.21	+0.30

**CHANGE IN MEAN STREAM FLOW (CFS)  
IN THE DESCHUTES BASIN AS A RESULT OF MITIGATED GROUNDWATER USE**

Effective Date: 9/30/2012

**Deschutes River below Pelton Dam**

Time: 15:49 Date: 04/10/2013

Month	Base Line CFS	Mitigated CFS	Change in CFS	Percent Change
January	5240.0	5220.0	-19.5	-0.37
February	5190.0	5170.0	-19.5	-0.38
March	5520.0	5500.0	-19.5	-0.35
April	5130.0	5120.0	-9.43	-0.18
May	4420.0	4420.0	+3.75	+0.08
June	4230.0	4240.0	+14.1	+0.33
July	4020.0	4040.0	+18.6	+0.46
August	3940.0	3950.0	+17.6	+0.45
September	3980.0	3990.0	+11.4	+0.29
October	4190.0	4190.0	+0.536	+0.01
November	4680.0	4660.0	-18.8	-0.40
December	5030.0	5010.0	-19.5	-0.39
Annual	4630.0	4630.0	-3.24	-0.07

**CHANGE IN PERCENT OF TIME INSTREAM REQUIREMENTS ARE MET  
IN THE DESCHUTES BASIN AS A RESULT OF MITIGATED GROUNDWATER USE**

Effective Date: 9/30/2012

**Metolius River at Lake Billy Chinook**

Time: 15:53

Date: 04/10/2013

Month	Base Line Percentage	Mitigated Percentage	Change in Percent	Percent Change
January	97.7	97.7	0.00	0.00
February	99.2	99.2	0.00	0.00
March	99.8	99.8	0.00	0.00
April	100.0	100.0	0.00	0.00
May	100.0	100.0	0.00	0.00
June	100.0	100.0	0.00	0.00
July	100.0	100.0	0.00	0.00
August	100.0	100.0	0.00	0.00
September	100.0	100.0	0.00	0.00
October	100.0	100.0	0.00	0.00
November	100.0	100.0	0.00	0.00
December	100.0	100.0	0.00	0.00
Annual	99.7	99.7	0.00	0.00

**CHANGE IN MEAN STREAM FLOW (CFS)  
IN THE DESCHUTES BASIN AS A RESULT OF MITIGATED GROUNDWATER USE**

Effective Date: 9/30/2012

**Metolius River at Lake Billy Chinook**

Time: 15:53

Date: 04/10/2013

Month	Base Line CFS	Mitigated CFS	Change in CFS	Percent Change
January	1510.0	1510.0	0.00	0.00
February	1560.0	1560.0	0.00	0.00
March	1560.0	1560.0	0.00	0.00
April	1520.0	1520.0	0.00	0.00
May	1560.0	1560.0	0.00	0.00
June	1590.0	1590.0	0.00	0.00
July	1490.0	1490.0	0.00	0.00
August	1400.0	1400.0	0.00	0.00
September	1350.0	1350.0	0.00	0.00
October	1330.0	1330.0	0.00	0.00
November	1370.0	1370.0	0.00	0.00
December	1450.0	1450.0	0.00	0.00
Annual	1470.0	1470.0	0.00	0.00



**CHANGE IN PERCENT OF TIME INSTREAM REQUIREMENTS ARE MET  
IN THE DESCHUTES BASIN AS A RESULT OF MITIGATED GROUNDWATER USE**

Effective Date: 9/30/2012

**Deschutes River at Lake Billy Chinook**

Time: 15:54

Date: 04/10/2013

Month	Base Line Percentage	Mitigated Percentage	Change in Percent	Percent Change
January	100.0	100.0	0.00	0.00
February	100.0	100.0	0.00	0.00
March	100.0	100.0	0.00	0.00
April	97.1	98.7	+1.56	+1.58
May	100.0	100.0	0.00	0.00
June	100.0	100.0	0.00	0.00
July	100.0	100.0	0.00	0.00
August	100.0	100.0	0.00	0.00
September	100.0	100.0	0.00	0.00
October	94.4	97.8	+3.44	+3.52
November	100.0	100.0	0.00	0.00
December	100.0	100.0	0.00	0.00
Annual	99.3	99.7	+0.42	+0.42

**CHANGE IN MEAN STREAM FLOW (CFS)  
IN THE DESCHUTES BASIN AS A RESULT OF MITIGATED GROUNDWATER USE**

Effective Date: 9/30/2012

**Deschutes River at Lake Billy Chinook**

Time: 15:54

Date: 04/10/2013

Month	Base Line CFS	Mitigated CFS	Change in CFS	Percent Change
January	1300.0	1290.0	-6.36	-0.49
February	1320.0	1310.0	-6.36	-0.49
March	1300.0	1290.0	-6.36	-0.49
April	843.0	846.0	+3.66	+0.43
May	552.0	567.0	+15.0	+2.65
June	606.0	628.0	+21.9	+3.49
July	550.0	576.0	+26.2	+4.56
August	519.0	545.0	+25.2	+4.64
September	537.0	556.0	+19.2	+3.44
October	725.0	734.0	+8.94	+1.22
November	1130.0	1120.0	-6.36	-0.57
December	1220.0	1210.0	-6.36	-0.52
Annual	881.0	880.0	+7.45	+0.84

**CHANGE IN PERCENT OF TIME INSTREAM REQUIREMENTS ARE MET  
IN THE DESCHUTES BASIN AS A RESULT OF MITIGATED GROUNDWATER USE**

Effective Date: 9/30/2012

**Deschutes River at Lower Bridge**

Time: 15:55

Date: 04/10/2013

Month	Base Line Percentage	Mitigated Percentage	Change in Percent	Percent Change
January	60.5	59.0	-1.51	-2.55
February	63.8	62.5	-1.30	-2.08
March	68.3	67.8	-0.43	-0.63
April	23.6	23.8	+0.22	+0.94
May	1.29	1.29	0.00	0.00
June	2.11	3.11	+1.00	+32.10
July	0.11	0.32	+0.22	+66.70
August	0.86	1.40	+0.54	+38.50
September	3.67	4.0	+0.33	+8.33
October	13.0	13.9	+0.86	+6.20
November	52.2	50.9	-1.33	-2.62
December	56.3	55.9	-0.43	-0.77
Annual	28.6	28.5	-0.15	-0.51

**CHANGE IN MEAN STREAM FLOW (CFS)  
IN THE DESCHUTES BASIN AS A RESULT OF MITIGATED GROUNDWATER USE**

Effective Date: 9/30/2012

**Deschutes River at Lower Bridge**

Time: 15:55 Date: 04/10/2013

Month	Base Line CFS	Mitigated CFS	Change in CFS	Percent Change
January	683.0	682.0	-1.41	-0.21
February	705.0	704.0	-1.41	-0.20
March	714.0	712.0	-1.41	-0.20
April	299.0	307.0	+8.61	+2.80
May	51.2	70.4	+19.20	+27.30
June	50.5	76.1	+25.60	+33.60
July	42.6	70.9	+28.30	+40.00
August	46.2	74.0	+27.80	+37.60
September	61.0	83.0	+22.00	+26.50
October	222.0	235.0	+12.80	+5.47
November	551.0	549.0	-1.41	-0.26
December	614.0	612.0	-1.41	-0.23
Annual	335.0	346.0	+11.50	+3.33

**CHANGE IN PERCENT OF TIME INSTREAM REQUIREMENTS ARE MET  
IN THE DESCHUTES BASIN AS A RESULT OF MITIGATED GROUNDWATER USE**

Effective Date: 9/30/2012

**Deschutes River above Diversion Dam at Bend**

Time: 15:56

Date: 04/10/2013

Month	Base Line Percentage	Mitigated Percentage	Change in Percent	Percent Change
January	37.3	37.2	-0.11	-0.29
February	40.0	39.6	-0.47	-1.19
March	42.9	42.3	-0.64	-1.53
April	73.2	73.4	+0.22	+0.30
May	97.0	97.5	+0.54	+0.55
June	100.0	100.0	0.00	0.00
July	100.0	100.0	0.00	0.00
August	100.0	100.0	0.00	0.00
September	97.0	97.8	+0.78	+0.80
October	54.6	56.2	+1.61	+2.87
November	29.0	28.8	-0.22	-0.77
December	35.7	35.5	-0.22	-0.61
Annual	67.4	67.5	+0.13	+0.19

**CHANGE IN MEAN STREAM FLOW (CFS)  
IN THE DESCHUTES BASIN AS A RESULT OF MITIGATED GROUNDWATER USE**

Effective Date: 9/30/2012

**Deschutes River above Diversion Dam at Bend**

Time: 15:56

Date: 04/10/2013

Month	Base Line CFS	Mitigated CFS	Change in CFS	Percent Change
January	712.0	711.0	-1.38	-0.19
February	738.0	737.0	-1.38	-0.19
March	781.0	779.0	-1.38	-0.18
April	877.0	881.0	+4.47	+0.51
May	1180.0	1190.0	+11.40	+0.96
June	1360.0	1370.0	+15.60	+1.13
July	1440.0	1450.0	+18.30	+1.26
August	1290.0	1310.0	+17.80	+1.36
September	1090.0	1110.0	+14.30	+1.29
October	721.0	730.0	+8.70	+1.19
November	590.0	589.0	-1.38	-0.23
December	650.0	648.0	-1.38	-0.21
Annual	953.0	960.0	+7.02	+0.73

**CHANGE IN PERCENT OF TIME INSTREAM REQUIREMENTS ARE MET  
IN THE DESCHUTES BASIN AS A RESULT OF MITIGATED GROUNDWATER USE**

Effective Date: 9/30/2012

**Deschutes River at Benham Falls**

Time: 15:56

Date: 04/10/2013

Month	Base Line Percentage	Mitigated Percentage	Change in Percent	Percent Change
January	43.4	43.3	-0.11	-0.25
February	54.5	54.5	0.00	0.00
March	32.5	31.4	-1.08	-3.42
April	69.6	69.3	-0.22	-0.32
May	78.1	78.1	0.00	0.00
June	92.6	92.6	0.00	0.00
July	96.8	96.8	0.00	0.00
August	94.5	94.6	+0.11	+0.11
September	67.8	67.9	+0.11	+0.16
October	54.0	54.0	0.00	0.00
November	35.9	35.7	-0.22	-0.62
December	44.6	44.6	0.00	0.00
Annual	63.7	63.6	-0.12	-0.19

**CHANGE IN MEAN STREAM FLOW (CFS)  
IN THE DESCHUTES BASIN AS A RESULT OF MITIGATED GROUNDWATER USE**

Effective Date: 9/30/2012

**Deschutes River at Benham Falls**

Time: 15:57 Date: 04/10/2013

Month	Base Line CFS	Mitigated CFS	Change in CFS	Percent Change
January	814.0	813.0	-1.33	-0.16
February	845.0	844.0	-1.33	-0.16
March	901.0	900.0	-1.33	-0.15
April	1240.0	1240.0	-1.33	-0.11
May	1850.0	1850.0	+0.604	+0.03
June	2100.0	2100.0	+1.82	+0.09
July	2200.0	2210.0	+4.57	+0.21
August	2040.0	2040.0	+4.06	+0.20
September	1730.0	1740.0	+3.58	+0.21
October	1000.0	1010.0	+3.01	+0.30
November	685.0	684.0	-1.33	-0.19
December	752.0	750.0	-1.33	-0.18
Annual	1350.0	1350.0	+0.824	+0.06

**CHANGE IN PERCENT OF TIME INSTREAM REQUIREMENTS ARE MET  
IN THE DESCHUTES BASIN AS A RESULT OF MITIGATED GROUNDWATER USE**

Effective Date: 9/30/2012

**Little Deschutes River at mouth**

Time: 15:57

Date: 04/10/2013

Month	Base Line Percentage	Mitigated Percentage	Change in Percent	Percent Change
January	22.9	20.8	-2.15	-10.4
February	37.3	34.6	-2.72	-7.85
March	27.4	27.1	-0.32	-1.19
April	45.2	44.9	-0.33	-0.74
May	55.9	55.8	-0.11	-0.19
June	56.6	57.2	+0.67	+1.17
July	85.1	87.5	+2.47	+2.83
August	93.9	94.3	+0.43	+0.46
September	72.0	73.3	+1.33	+1.82
October	11.6	12.9	+1.29	+10.00
November	14.7	14.0	-0.67	-4.76
December	20.3	19.7	-0.64	-3.28
Annual	45.3	45.2	-0.05	-0.10

**CHANGE IN MEAN STREAM FLOW (CFS)  
IN THE DESCHUTES BASIN AS A RESULT OF MITIGATED GROUNDWATER USE**

Effective Date: 9/30/2012

**Little Deschutes River at mouth**

Time: 15:57

Date: 04/10/2013

Month	Base Line CFS	Mitigated CFS	Change in CFS	Percent Change
January	162.0	161.0	-1.32	-0.82
February	183.0	182.0	-1.32	-0.73
March	219.0	218.0	-1.32	-0.61
April	262.0	261.0	-1.32	-0.51
May	329.0	329.0	+0.609	+0.19
June	289.0	300.0	+1.83	+0.61
July	230.0	235.0	+4.74	+2.02
August	200.0	204.0	+4.19	+2.05
September	144.0	147.0	+3.67	+2.49
October	76.7	79.8	+3.10	+3.88
November	108.0	107.0	-1.32	-1.24
December	142.0	141.0	-1.32	-0.94
Annual	196.0	197.0	+0.868	+0.44

**CHANGE IN PERCENT OF TIME INSTREAM REQUIREMENTS ARE MET  
IN THE DESCHUTES BASIN AS A RESULT OF MITIGATED GROUNDWATER USE**

Effective Date: 9/30/2012

**Deschutes River above Little Deschutes River**

Time: 15:58

Date: 04/10/2013

Month	Base Line Percentage	Mitigated Percentage	Change in Percent	Percent Change
January	29.7	29.7	0.00	0.00
February	30.1	30.1	0.00	0.00
March	33.5	33.5	0.00	0.00
April	68.4	68.4	0.00	0.00
May	97.8	97.8	0.00	0.00
June	98.8	98.8	0.00	0.00
July	100.0	100.0	0.00	0.00
August	100.0	100.0	0.00	0.00
September	99.8	99.8	0.00	0.00
October	56.8	56.8	0.00	0.00
November	20.9	20.9	0.00	0.00
December	24.7	24.7	0.00	0.00
Annual	63.5	63.5	0.00	0.00

**CHANGE IN MEAN STREAM FLOW (CFS)  
IN THE DESCHUTES BASIN AS A RESULT OF MITIGATED GROUNDWATER USE**

Effective Date: 9/30/2012

**Deschutes River above Little Deschutes River**

Time: 15:58

Date: 04/10/2013

Month	Base Line CFS	Mitigated CFS	Change in CFS	Percent Change
January	329.0	329.0	0.00	0.00
February	331.0	331.0	0.00	0.00
March	319.0	319.0	0.00	0.00
April	654.0	654.0	0.00	0.00
May	1220.0	1220.0	0.00	0.00
June	1500.0	1500.0	0.00	0.00
July	1690.0	1690.0	0.00	0.00
August	1530.0	1530.0	0.00	0.00
September	1260.0	1260.0	0.00	0.00
October	561.0	561.0	0.00	0.00
November	246.0	246.0	0.00	0.00
December	280.0	280.0	0.00	0.00
Annual	829.0	829.0	0.00	0.00

# Assessing the Impact of Mitigation on Stream Flow in the Deschutes Basin

Open File Report SW 08-001



State of Oregon  
Water Resources Department



# Assessing the Impact of Mitigation on Stream Flow in the Deschutes Basin

By Richard M. Cooper

---

State of Oregon  
Water Resources Department

Open File Report SW 08-001

Salem, Oregon  
November 2008

---

Cover photograph: The Deschutes River, courtesy of g. white.



# Contents

Introduction .....	1
A Mathematical Model.....	1
Resolution of the Model .....	2
In-stream Flow Requirements.....	4
Modeling Versus Real Time Monitoring of Stream Flow.....	4
Modeling the Groundwater Surface Water Interaction.....	5
Description of the Mathematical Model.....	11
Mitigation .....	19
Groundwater Withdrawals.....	20
Zone of Impact Determination.....	20
Groundwater Rights with the 7J Condition.....	21
Assumptions of the Model.....	21
Short Comings of the Model .....	22
References .....	22
Appendix A – Leases and Transfers.....	23
Appendix B – Groundwater Withdrawals .....	33
Appendix C – Appendix C - Zone of Impact Determination for a Mitigation Project By Jonathan L. La Marche .....	39
Appendix D - Zone Of Impact Determination for a Groundwater Withdrawal By Kenneth E. Lite, Jr. ....	43

# Figures

Figure 1. Deschutes Basin locations where the impacts of mitigation activities are accumulated or analyzed .....	7
Figure 2. General zone of impact .....	12
Figure 3. Crooked River zone of impact.....	13
Figure 4. Metolius River zone of impact .....	14
Figure 5. Whychus Creek zone of impact .....	15
Figure 6. Middle Deschutes River zone of impact.....	16
Figure 7. Upper Deschutes River zone of impact.....	17
Figure 8. Little Deschutes River zone of impact.....	18
Figure A-1. Where the diversion and the zone of impact are both on the Deschutes River, showing the conceptual models for the cases before (A) and after (B) implementation of a lease or transfer .....	28

Figure A-2.	Where the diversion is on the Deschutes River and the zone of impact is on the Crooked River, showing the conceptual models for the cases before (A) and after (B) implementation of a lease or transfer .....	29
Figure A-3.	A simplified schematic showing the change in streamflow for various reaches of the Deschutes and Crooked Rivers as a result of the in-stream lease given in the example...	32
Figure B-1.	Where the diversion and the zone of impact are both on the Deschutes River, showing the conceptual models for the cases before (A) and after (B) implementation of a groundwater withdrawal .....	34
Figure B-2.	Where the diversion is on the Deschutes River and the zone of impact is on the Crooked River, showing the conceptual models for the cases before (A) and after (B) implementation of a groundwater withdrawal .....	35
Figure B-3.	A simplified schematic showing the change in streamflow for various reaches of the Deschutes and Crooked Rivers as a result of the groundwater withdrawal given in the example .....	38
Figure C-1.	A map showing the locale near the place of use (POU) for a water right for irrigation that is to be leased in-stream.....	41

## Tables

Table 1.	Locations on the Deschutes River and its tributaries where streamflow impacts are accumulated .....	3
Table 2.	Deschutes Basin “analysis locations” where the effect of mitigation activities on the frequency in-stream requirements are met may be evaluated .....	5
Table 3.	An example illustrating the difference between additive instream requirements (i.e., instream transfers and leases) and non-additive instream requirements (i.e., instream water rights, scenic waterways, and tribal agreements) .....	8
Table 4.	In-stream requirements at each of the eight analysis locations in the Deschutes Basin.....	9
Table 5.	Percent of days the in-stream requirement is met annually in the Deschutes River below Pelton Dam (Gaging Station 14092500).....	10
Table 6.	The zones of impact and their associated watersheds .....	11
Table 7.	Percent of days the in-stream requirement is met by month in the Deschutes River below Pelton Dam (Gaging Station 14092500) for the period, water years 1966 to 1995.....	19
Table A-1.	An example of an in-stream transfer showing the amount diverted annually, the consumptive use and the return flows associated with the original water right, the seasonal distribution of the in-stream flow requirements, and the stream reaches where the requirements are applied .....	24
Table A-2.	Examples showing the effect on streamflow of a change in in-stream requirement with and without the presence of users able to divert the unprotected water .....	25
Table A-3.	Examples showing the effect on streamflow of the loss of return flow with and without an in-stream requirement and with and without the presence of users able to divert any unprotected water. ....	25
Table A-4.	The numerical model for a transfer or lease .....	26
Table A-5.	Model assumptions for a transfer or lease.....	27

Table A-6.	The required model input for a transfer or lease.....	27
Table A-7.	Estimated impact from a mitigation project on streamflow for four stream reaches in the Deschutes River basin .....	31
Table B-1.	The numerical model for groundwater withdrawals .....	36
Table B-2.	Model assumptions for groundwater withdrawals .....	36
Table B-3.	The required model input for groundwater withdrawals .....	36
Table B-4.	Estimated impact from a mitigated groundwater withdrawal on streamflow for four stream reaches in the Deschutes River basin .....	37
Table C-1.	Information required for the determination of the zone of impact affected by a proposed mitigation project .....	40

## Acknowledgments

Many thanks are due Ken Stahr for creating the maps used in this report. Jonathan La Marche and Laura Snedaker of the Oregon Water Resources Department and Marshall Gannett of the U.S. Geological Survey reviewed the report and made many valuable observations and criticisms. The report was greatly improved through their efforts.

The following information is provided for your information. This information is not intended to be used as a substitute for professional advice. The information is provided for your information only and should not be used as a substitute for professional advice. The information is provided for your information only and should not be used as a substitute for professional advice.

### Additional Comments

The following information is provided for your information. This information is not intended to be used as a substitute for professional advice. The information is provided for your information only and should not be used as a substitute for professional advice.

# Assessing the Impact of Mitigation on Streamflow in the Deschutes Basin

By Richard M. Cooper

## Introduction

Surface water in the upper Deschutes Basin is over-appropriated in most areas at most times of the year.<sup>1</sup> As a result, opportunities for new surface water appropriation in the basin are limited, and attention has turned to groundwater as a source for new appropriations. However, groundwater and surface water are directly linked in the Deschutes Basin (Sceva, 1960, 1968; Gannett and others, 2001). For many streams, groundwater discharge to surface water is the primary source of streamflow. Where this is the case, withdrawals from groundwater have a direct impact on streamflows.

In order to prevent further diminishment of the surface water resource due to groundwater withdrawals, the Oregon Water Resources Commission adopted the Deschutes Groundwater Mitigation Rules (OAR Chapter 690, Division 505) in September 2002. The rules require that new allocations of groundwater be mitigated to counter their effect on surface water flow. Because it is expected that the activities allowed under the rules will still have some effect on streamflow and may impact how often in-stream flow requirements are met, the rules require that the Oregon Water Resources Department (OWRD) monitor and evaluate the effects of mitigation and groundwater allocation on streamflow throughout the basin. Specifically, the OWRD is required to “determine whether scenic waterway flows and in-stream water right flows in the Deschutes Basin continue to be met on at least an equivalent or more frequent basis as compared to long-term,

representative base period flows established by the Department” (OAR 690-505-0500(3)).

To make this evaluation, the impacts of groundwater withdrawals and mitigation projects on streamflow are characterized as changes in the frequencies the various in-stream flow requirements are met. Streamflow impacts may have either a positive or negative effect on these frequencies depending on the type of activity, location, and season of the year. Summed at specified locations, the changes in frequency are a quantitative measure of the effectiveness of the mitigation program.

The “before mitigation” or baseline condition of streams in the Deschutes Basin is determined from streamflows measured during water years 1966 to 1995. This base period is after all reservoirs were built and before the Department included a condition on groundwater permits providing for possible regulation under the State Scenic Waterway Act, i.e., the so called “7J condition” (OAR 690-310-260 (9)(g)). Water rights with the 7J condition are discussed in a later section. With the adoption of the mitigation rules, the OWRD now adds a further condition that a groundwater right issued with mitigation will not be subject to regulation as long as the mitigation is maintained.

## A Mathematical Model

A computer program has been developed by the OWRD to mathematically estimate (i.e., model) the *change* in streamflow expected due to mitigation and groundwater allocation. The model then determines if these streamflow impacts will change the frequency with which in-stream flow requirements in the basin are met.

In the model, it is possible to estimate the streamflow impacts due to mitigation and groundwater allocation at numerous locations. However, determining if these impacts change the frequency with which the in-stream flow

---

<sup>1</sup> Over-appropriation is defined in the Water Allocation Policy adopted by the Water Resources Commission in July 1992. Refer to OAR 690-400-010(11)(a)(A). For further discussion, see Cooper, 2002.

requirements are met is possible only where a long term and continuous record of historic streamflow is available. For these “analysis locations”, the historic time series is modified by the streamflow impacts accumulated for that location. Then the percent of time the in-stream flow requirements are met is calculated for both the original and the modified time series allowing changes in frequency due to streamflow impacts to be determined.

Whether an in-stream flow requirement is met is determined on a daily basis (using *mean* daily flows as the basis for comparison) and is reported as the percent of days the in-stream flow requirements are met both monthly and annually. Output from the model includes the accumulated impacts on streamflow at many locations, and where possible, the expected changes in the frequencies with which the in-stream flow requirements are met. These statistics are reported monthly and annually.

## Resolution of the Model

The mathematical model is based on the methodology the OWRD uses to assess water availability (Cooper, 2002). In that methodology, a large basin such as the Deschutes is divided into a number of subunits called Water Availability Basins or WABs. Each WAB represents a watershed and is identified by the location of its ‘pour point’ or outlet (e.g., Deschutes River above Tumalo Creek). In addition, each WAB has a unique identification number. For this report, the WABs are referred to simply as watersheds.

The Deschutes Basin is divided into 184 watersheds; 50 of which are of interest here. Each of these 50 watersheds is shown in Table 1 along with its identification number and a ‘key number’ that may be used to locate the watershed pour point on the various maps used in this report. Using the water availability methodology, the streamflow impacts due to the various mitigation activities are determined and then accumulated at the watershed pour points. The stretches of the streams between watershed pour points are referred to as ‘stream reaches’ or simply ‘reaches’.

The degree to which mitigation impacts can be evaluated depends on the availability of historic

streamflow data. For all watershed pour points where streamflow impacts are accumulated, a report may be generated detailing the monthly and annual changes in streamflow expected to occur. These expected changes show clearly whether streamflows are increasing or decreasing due to mitigation activities, allowing a qualitative evaluation of the impact mitigation is having on streamflow. To make the more rigorous assessment of the impact of the changes in streamflow on the frequency the in-stream flow requirements are met requires knowledge of the streamflows that occurred at those locations during the base period. Unfortunately, for most watershed pour points, these streamflows are unknown. In those few locations where suitable streamflow records are available, however, the rigorous assessment can be made.

The impact of the various mitigation activities on the percent of time in-stream flow requirements are met may be evaluated only where a continuous time series of mean daily streamflows is available for the period 1966 to 1995. There are eight such locations on the Deschutes River and its tributaries suitable for making this assessment. Streamflow at each of these analysis locations may be represented by records from a single station or a combination of stations.

At three locations, the gaging station is upstream of the pour point of the watershed where the streamflow impacts are accumulated: 1) the Deschutes River below Bend, 2) the Little Deschutes River, and 3) the Deschutes River above the Little Deschutes River. In each case, some error occurs in assessing the impact on the frequency the in-stream flow requirement is met because inflows between the gaging station and the pour point are not accounted for. The effect on the analysis is to underestimate the amount of time the in-stream flow requirements are met. For the later two locations, for the base period, the unaccounted inflows are small compared to main stem flows. The associated errors are therefore also small. For the first location, however, while unaccounted inflows are small compared to main stem flows in the summer, they may be a significant part of winter flows (Jonathan LaMarche, OWRD hydrologist, personal communication, 2008).

**Table 1.** Locations on the Deschutes River and its tributaries where streamflow impacts are accumulated. Locations are at the pour points of the specified watersheds.

<b>Map Key</b>	<b>Watershed ID #</b>	<b>Watershed Name</b>
1	70087	Deschutes River at mouth
2	30530616	Deschutes River above White River
3	30530627	Deschutes River above Eagle Creek
4	30530637	Deschutes River above Warm Springs River
5	30530643	Deschutes River below Pelton Dam
6	30530101	Metolius River at mouth
7	30530102	Juniper Creek at mouth
8	30530103	Big Canyon at mouth
9	70761	Fly Creek at mouth
10	70755	Spring Creek at mouth
11	30530104	Street Creek at mouth
12	70698	Metolius River above Street Creek
13	30530105	Whitewater River at mouth
14	70697	Jefferson Creek at mouth
15	70694	Candle Creek at mouth
16	30530116	Metolius River above Candle Creek
17	70766	Abbot Creek at mouth
18	70693	Canyon Creek at mouth
19	70699	Metolius River above Canyon Creek
20	70354	Crooked River at Lake Billy Chinook
21	30530508	Crooked River above Osborne Can
22	30530501	Dry River at mouth
23	30530507	Crooked River above Dry River
24	70595	McKay Creek at mouth
25	70611	Ochoco Creek at mouth
26	30530506	Dry Creek at mouth
27	70606	Bear Creek at mouth
28	70353	Crooked River above Prineville Reservoir
29	70357	North Fork Crooked River at mouth
30	73199	Crooked River above North Fork Crooked River
31	70695	Deschutes River above Lake Billy Chinook
32	70753	Whychus Creek at Mouth
33	70760	Indian Ford Creek at mouth
34	70754	Whychus Creek above Indian Ford Creek
35	30530112	Deschutes River above Buckhorn Canyon
36	70752	Tumalo Creek at mouth
37	197	Deschutes River above Tumalo Creek
38	30530114	Deschutes River above COID Diversion
39	30530138	Deschutes River at Benham Falls
40	73329	Spring River at mouth
41	198	Deschutes River above Spring River
42	70757	Little Deschutes River at mouth
43	30530202	Paulina Creek at mouth
44	30530203	Long Prairie Slough at mouth
45	70765	Crescent Creek at mouth
46	70758	Little Deschutes River above Crescent Creek
47	199	Deschutes River above Little Deschutes River
48	70762	Fall River at mouth
49	73325	Browns Creek at mouth
50	70764	Deschutes River above Browns Creek

Several other long-term gaging stations are located in the Deschutes Basin but are not considered for analysis. Although these gaging stations occur in river reaches with in-stream flow requirements, they are not suitable for either of two reasons: 1) streamflow at the gaging station does not adequately represent streamflow for the reach (e.g., there are unaccounted for diversions), or 2) the station is high in the watershed and impacts from mitigation or groundwater withdrawals are not expected.

The eight analysis locations are shown in Table 2 and on Figure 1.

## In-stream Flow Requirements

Each of the eight analysis locations is in a river reach affected by one or more in-stream flow requirements. For this discussion, in-stream flow requirements are divided into two types: additive and non-additive.

For non-additive in-stream flow requirements, at locations with more than one requirement, the effective requirement is the largest of the requirements – the requirements do not sum. Non-additive in-stream flow requirements may be the result of an in-stream water right (ISWR)<sup>2</sup>, a scenic waterway (SWW), or a treaty with the Warm Spring Tribes (Treaty).

Additive in-stream flow requirements result from the lease, transfer, or allocation of conserved water from an out-of-stream water right to an in-stream water right. These requirements are additive among themselves, but are not additive with the various types of non-additive in-stream flow requirements. Generally, an additive in-stream water right is much smaller than a non-additive in-stream flow requirement and has an earlier priority date. When occurring in the same stream reach, an additive in-stream water right replaces only a portion of a non-additive in-stream flow requirement. The benefit to the

stream derives from the earlier priority date of the additive water right. These concepts are illustrated by a hypothetical example in Table 3.

The resultant in-stream flow requirements for the eight locations are given in Table 4.

## Modeling Versus Real Time Monitoring of Streamflow

It is sometimes suggested that the effects of mitigation and groundwater allocation be determined by real time monitoring of streamflow rather than use of a mathematical model. Real time monitoring of streamflows is not used for three reasons: 1) there must be a basis for comparison, 2) it may take many years for the effects of a mitigation project or a groundwater allocation to be fully realized, and 3) activities in the basin other than mitigation may affect streamflow. Each of these reasons is discussed in detail.

**Reason 1** Evaluation of the effects of mitigation and groundwater withdrawals on streamflow requires a comparison of streamflows occurring with and without these activities. Although a comparison could be made using streamflow measurements made before and after the initiation of mitigation and groundwater withdrawals, the comparison would not be useful. The changes in streamflow due to mitigation and groundwater withdrawals are expected to be small compared to natural variation in streamflow due to changes in weather from season to season and year to year. The small changes would be masked by the much larger natural variations, and there would be no way to distinguish between the two types of change. Unfortunately there is no good way to remove or compensate for the natural variation.

Table 5 illustrates the magnitude of the natural variations in streamflow likely to occur. It shows the percent of days the in-stream flow requirement was met at the USGS gaging station located on the Deschutes River just below Pelton Dam near Madras for the period 1966 to 1995. The percent of days varies from 28.8 percent in 1992 to 100 percent in 1984.

---

<sup>2</sup> Non-additive in-stream water rights may be established under the state agency in-stream water right application process (ORS 537.341) or conversion of minimum perennial streamflow to an in-stream water right (ORS 537.346).



**Table 2.** Deschutes Basin “analysis locations” where the effect of mitigation activities on the frequencies with which in-stream flow requirements are met may be evaluated.

Map Key	Location	Representative Gaging Station(s)	Associated Watershed
A	Deschutes River at the mouth	14103000	70087
B	Deschutes River below Pelton Dam	14092500	30530643
C	Metolius River at Billy Chinook	14091500	70698
D	Deschutes River downstream of Bend	14070500	30530112
E	Deschutes River upstream of Bend	14070500 + 4 canals *	197
F	Deschutes River at Benham Falls	14064500	30530138
G	Little Deschutes River at mouth	14063000	70757
H	Deschutes River above Little Deschutes River	14056500 + 14057500 **	199

\* The four canals are the DCMID (14068500), the North Unit Main (14069000), the North (14069500), and the Swalley (14070000).

\*\* 14056500 is the Deschutes River below Wickiup Reservoir near La Pine, OR, and 14057500 is Fall River near La Pine, OR.

**Reason 2** The effects of some mitigation projects and groundwater allocations may not be fully realized for many years. Some delay results from the time it takes to implement these activities, but more so because of the time it takes for changes to propagate through the groundwater system. Gannett and Lite (2004) demonstrate that the effects of ground-water pumping on streamflow accumulate over a period of weeks or decades depending on the location of pumping. This time delay means that decisions about new mitigation or groundwater allocation could be made with the effects of existing mitigation or allocation either over- or under-estimated, respectively. Using a model based on historic streamflow provides a basis for comparison and allows the effects of mitigation to be computed at full realization.

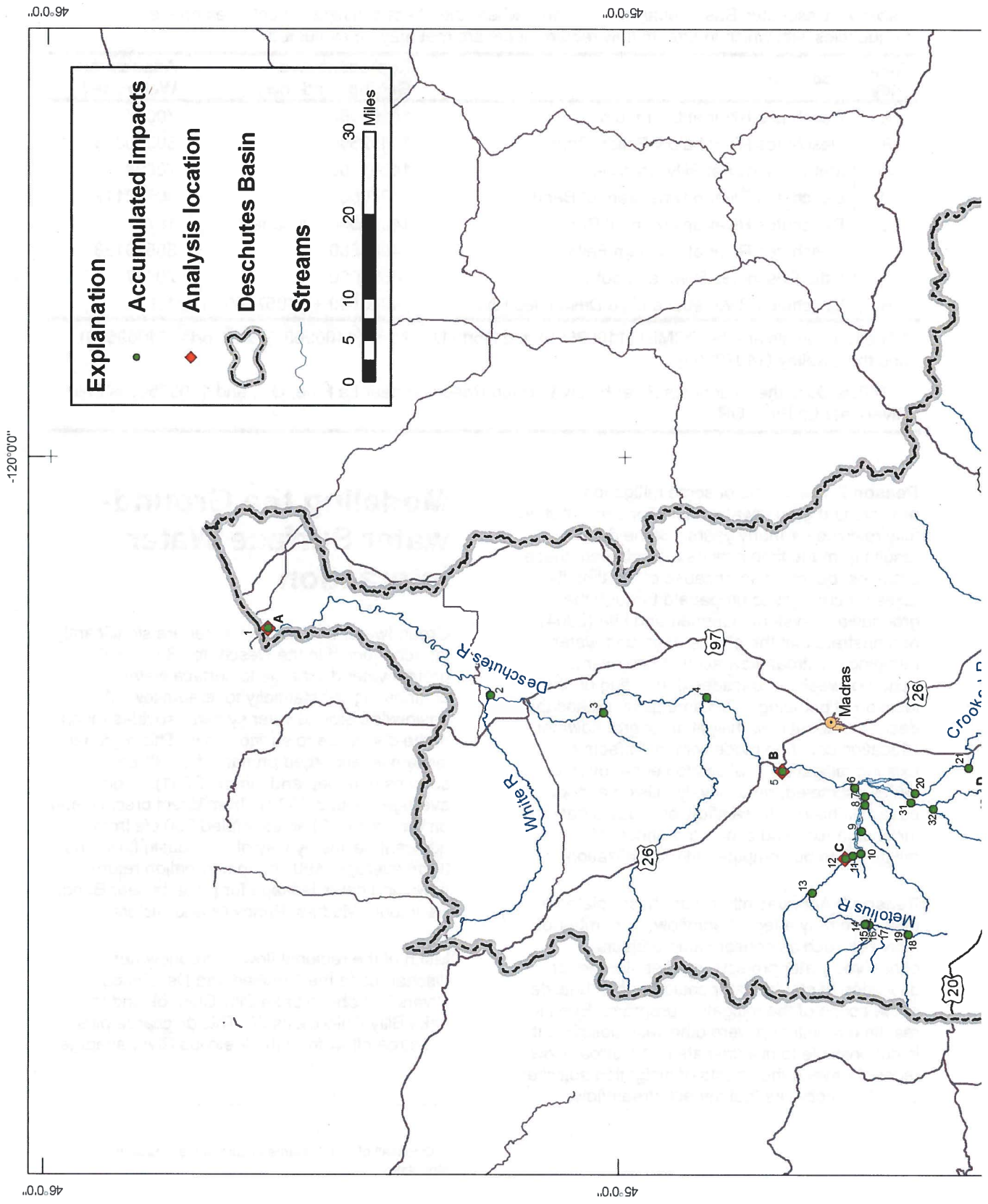
**Reason 3** Activities other than those related to mitigation may affect streamflow. A number of activities such as conservation projects, conserved water projects, aquifer storage, or allocation of stored water could happen outside of the scope of the mitigation program. Even if real time monitoring were otherwise possible, it is not possible to discriminate in the streamflow record between the effects of mitigation activities and other activities that impact streamflow.

## Modeling the Ground-water Surface Water Interaction

Groundwater and surface water are significantly interconnected in the Deschutes Basin with groundwater discharge to surface water contributing substantially to streamflow. A basin-wide groundwater system provides much of the discharge to surface flow. This regional system is recharged primarily from three sources (Gannett and others, 2001): 1) on average about 3,500 cfs from direct precipitation on the basin<sup>3</sup>, 2) an estimated 850 cfs from adjacent basins by way of inter-basin flow, and 3) on average, 490 cfs from irrigation return flows and canal leakage for projects near Bend, Redmond, Madras, Prineville and Sisters.

Much of the regional flow of groundwater discharges to the Crooked and Deschutes Rivers just above Lake Billy Chinook and to Lake Billy Chinook itself. This discharge plus the streamflow from the Metolius River average

<sup>3</sup> Almost all of this recharge occurs in the Cascade Mountains.



**Explanation**

- Accumulated impacts
- ◆ Analysis location
- ▭ Deschutes Basin
- ~ Streams

0 5 10 20 30 Miles

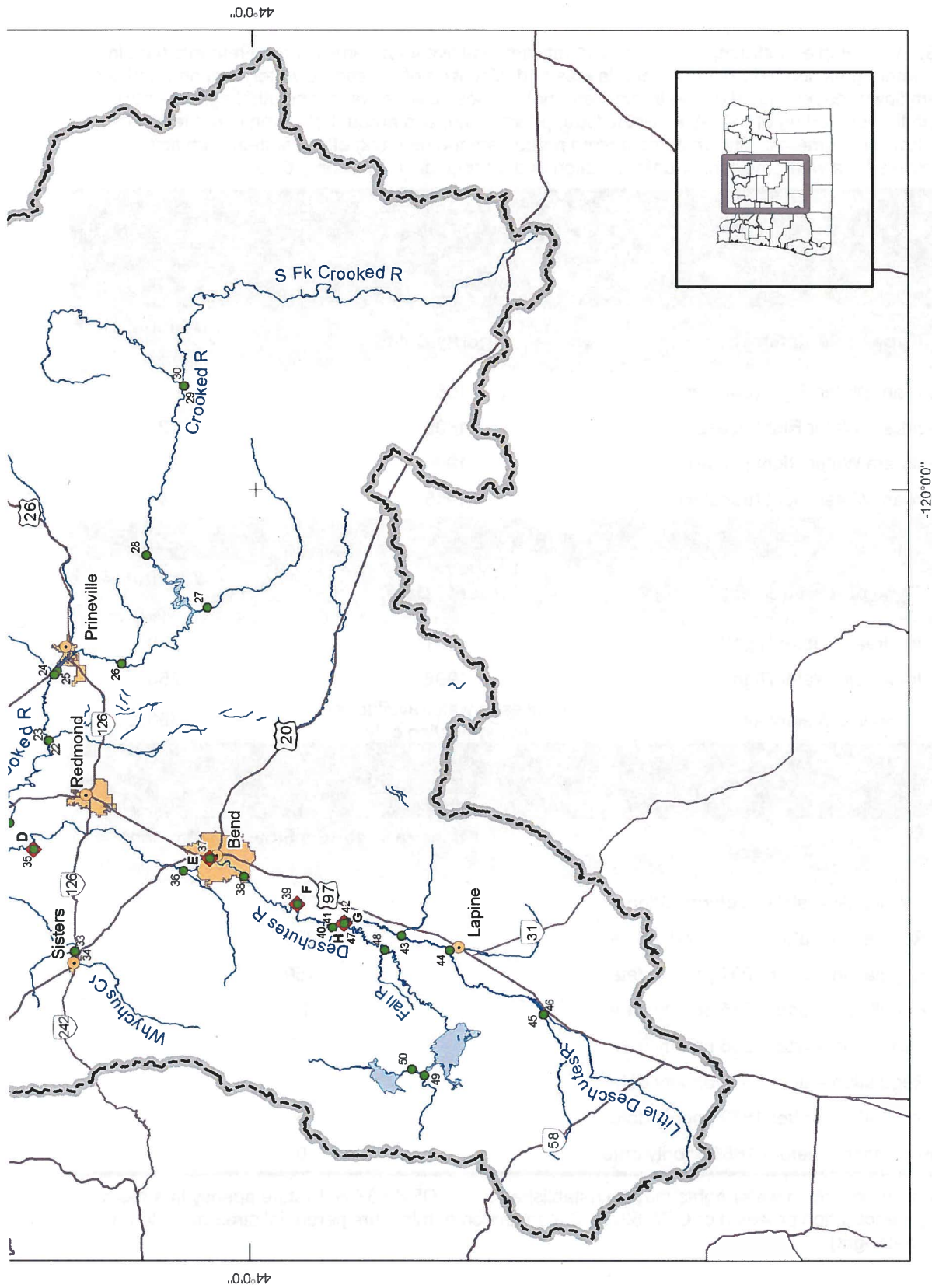
46°0'0"

45°0'0"

-120°0'0"

46°0'0"

45°0'0"



**Figure 1.** Deschutes Basin locations where the impacts of mitigation activities are accumulated or analyzed. See Table 1 for a map key to accumulated impacts and Table 2 for a map key to the analysis locations.

**Table 3.** An example illustrating the difference between additive in-stream flow requirements (i.e., in-stream water rights derived from transfers, leases and allocation of conserved water) and non-additive in-stream flow requirements (i.e., in-stream water rights\*, scenic waterways, and tribal agreements). Shown in the top portion of the table are the type, priority date, and amount of seven hypothetical in-stream flow requirements. Shown in the bottom portion are the resulting effective in-stream flow requirements for a water availability determination and for regulation by priority date.

In-stream Flow Requirements		
Additive		
Type of Requirement	Priority Date	Amount cfs
In-stream Water Right (transfer)	1889	5
In-stream Water Right (lease)	1895	2
In-stream Water Right (lease)	1905	5
In-stream Water Right (transfer)	1915	4
Non-Additive		
Type of Requirement	Priority Date	Amount cfs
In-stream Water Right*	1991	150
In-stream Water Right*	1992	250
Scenic Waterway	Applies to water availability determination only	300
Effective In-stream Flow Requirements		
Purpose	Effective In-stream Flow Requirement cfs	
Water Availability Determination	300	
Regulation – after 1992 priority date	250	
Regulation – after 1991 priority date	150	
Regulation – after 1915 priority date	16	
Regulation – after 1905 priority date	12	
Regulation – after 1895 priority date	7	
Regulation – after 1889 priority date	5	
Regulation – before 1889 priority date	0	

\*Non-additive In-stream water rights may be established under ORS 537.341 (state agency in-stream water right application process) or ORS 537.346 (conversion of minimum perennial streamflow to an in-stream water right).

**Table 4. In-stream flow requirements at each of the eight analysis locations in the Deschutes Basin.**

Gage(s)	14103000 Deschutes River at the mouth		14092500 Deschutes River below Pelton Dam		14091500 Metolius River at Lake Billy Chinook		14070500 Deschutes River downstream of Bend		14070500 + 4 canals Deschutes River upstream of Bend		14064500 Deschutes River at Benham Falls		14064500 + 14057500 Deschutes River above Little Deschutes River		14063000 Little Deschutes River at mouth		
	Type of in-stream flow requirement	SWWW	SWWW	Treaty	SWWW	SWWW	SWWW	SWWW	SWWW	SWWW	SWWW	SWWW	SWWW	SWWW	SWWW	ISWR	
Zone of impact	N/A	General	Metolius River	Middle Deschutes River	Middle Deschutes River	Middle Deschutes River	Middle Deschutes River	Upper Deschutes River	Upper Deschutes River	Upper Deschutes River	Upper Deschutes River	Upper Deschutes River	Upper Deschutes River	Upper Deschutes River	Little Deschutes River	Little Deschutes River	
Jan	4500	4500	1150	500	660	660	660	660	660	660	660	660	660	660	660	200	200
Feb	4500	4500	1150	500	660	660	660	660	660	660	660	660	660	660	660	200	200
Mar	4500	4500	1160	500	660	660	660	660	660	660	660	660	660	660	660	236	236
Apr	4000	4000	1160	500	660	660	660	660	660	660	660	660	660	660	660	240	240
May	4000	4000	1240	250	660	660	660	660	660	660	660	660	660	660	660	240	240
Jun	4000	4000	1200	250	660	660	660	660	660	660	660	660	660	660	660	200	200
Jul	4000	4000	1170	250	660	660	660	660	660	660	660	660	660	660	660	126	126
Aug	3500	3500	1140	250	660	660	660	660	660	660	660	660	660	660	660	74.5	74.5
Sep	3500	3500	1100	250	660	660	660	660	660	660	660	660	660	660	660	92.2	92.2
Oct	3800	3800	1080	500	660	660	660	660	660	660	660	660	660	660	660	116	116
Nov	3800	3800	1140	500	660	660	660	660	660	660	660	660	660	660	660	164	164
Dec	4500	4500	1110	500	660	660	660	660	660	660	660	660	660	660	660	196	196

**Table 5.** Percent of days the in-stream requirement is met annually in the Deschutes River below Pelton Dam (Gaging Station 14092500).

Year	Percent of days per year	Average number of days per year
1966	58.1	212
1967	53.7	196
1968	35.0	128
1969	56.4	206
1970	66.6	243
1971	84.9	310
1972	94.3	344
1973	63.3	231
1974	95.1	347
1975	99.7	364
1976	99.7	364
1977	54.0	197
1978	82.2	300
1979	69.9	255
1980	59.3	216
1981	64.9	237
1982	99.7	364
1983	99.5	363
1984	100.0	365
1985	94.2	344
1986	92.9	339
1987	80.0	292
1988	59.3	216
1989	69.9	255
1990	45.2	165
1991	28.8	105
1992	28.7	105
1993	59.2	216
1994	31.0	113
1995	54.5	199
Long Term	69.3	253

about 4,000 cfs - nearly all of the summer streamflow in the lower Deschutes.

Local discharge from groundwater plays an important role in the basin. See Gannett and others (2001) for information about stream reaches with significant local groundwater discharge. Of interest here is assigning the impact of a mitigation project or a groundwater withdrawal to discharge along an appropriate stream reach. Does the project or groundwater withdrawal affect discharge to a local stream reach or does it affect the regional discharge near Lake Billy Chinook?

The OWRD defines seven 'zones of impact' to describe watersheds that include and are above areas (i.e., stream reaches) of significant groundwater discharge to surface water. To define boundaries for the local zones of impact, the OWRD considered sub-basin boundaries, locations where in-stream water rights or scenic waterway flows are not being met, general ground water flow information, and other hydrogeologic information, including identification of stream reaches influenced by groundwater discharge. By defining the boundaries for each of the local zones of impact, mitigation may be targeted to areas where mitigation projects may provide the greatest in-stream benefits (Kenneth L. Lite, written Communication, 2008).

One of the zones of impact is the regional or general zone of impact near Billy Chinook (Figure 2). The other six local zones are: 1) the Crooked River above river mile 13.8, 2) the Metolius River above river mile 28, 3) the Middle Deschutes River above river mile 125, 4) Whychus Creek above river mile 16, 5) the Upper Deschutes River above river mile 185, excluding the Little Deschutes, and 6) the Little Deschutes River above the mouth (Figures 3 to 8, respectively). See Table 6 for the watersheds associated with each zone of impact.

Also shown on Figures 2 to 8 are the locations where changes in streamflow are analyzed and the locations of the affected in-stream flow requirements. Note that some zones of impact have more than one analysis location. Conversely, the Whychus Creek and the Crooked River zones of impact are not represented at all, as there is not a suitable gaging station for either zone.

**Table 6.** The zones of impact and their associated watersheds.

<b>Zone of Impact</b>	<b>Associated Watershed</b>
General	30530643
Metolius River	70698
Crooked River	30630508
Middle Deschutes River	70695
Whychus Creek	70753
Upper Deschutes River	30530138
Little Deschutes River	70757

For the Whychus Creek zone, the one long-term gage, Whychus Creek near Sisters, OR (14075000), is located above the expected impacts of mitigation or groundwater withdrawals. Although the major diversion from Whychus Creek (the Three Creek Irrigation District Canal) is gaged and could be used to 'correct' the record for the gage, another 20 cfs or so of diversion is unaccounted for. For the Crooked River zone, a gaging station is located at an appropriate location (just below Osborne Canyon), but its period of record does not coincide with the selected base period, 1966 to 1995.

The zone of impact determination is discussed in a later section.

## Description of the Mathematical Model

The model mathematically estimates the impacts on streamflow of the various mitigation projects and groundwater allocations permitted under the Deschutes Groundwater Mitigation Rules. It then determines if these impacts change the frequency with which in-stream flow requirements in the basin are met.

The estimated streamflow impacts are independent of the actual streamflow, that is, they represent the *change* in streamflow. Because actual streamflows are not required, these impacts can be estimated and

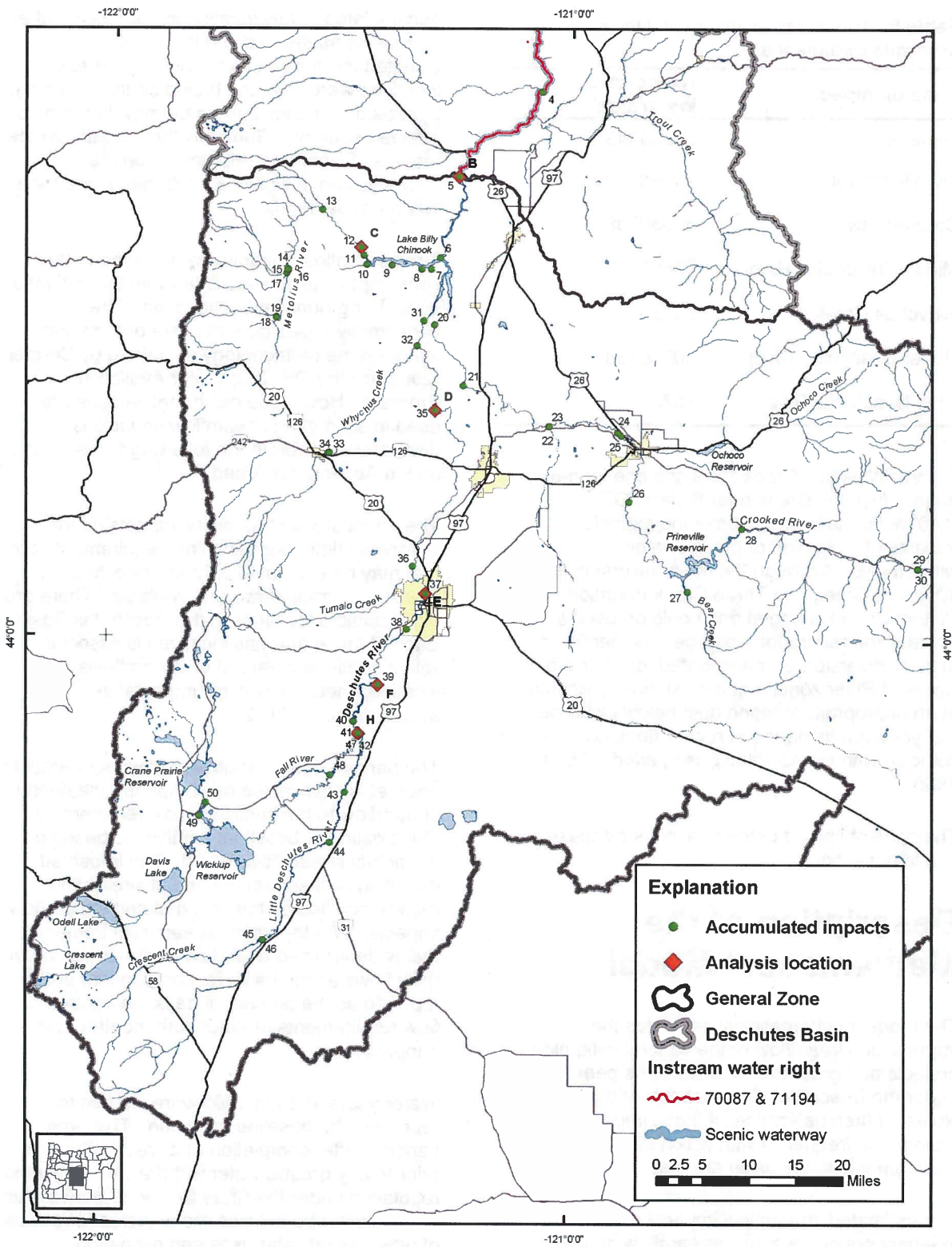
accumulated at any location in the basin, but as a practical matter, only 50 locations were selected for this purpose (Table 1). These locations were selected based on the location of in-stream demands and on the physiography of affected streams. Generally they are above the mouths of significant tributaries, on main channels above significant tributaries and for all in-stream demands.

The streamflow impacts are all based on the consumptive uses associated with the mitigation project or groundwater allocation. The consumptive uses generally are determined following the methodology described by Cooper (2002) for the OWRD's Water Availability Program. How these consumptive uses are used in estimating streamflow impacts is discussed in detail in the following two sections and in Appendices A and B.

The effect of the streamflow impacts on the percent of time in-stream flow requirements are met may be evaluated only where actual measured streamflows are available. There are eight suitable locations in the Deschutes Basin. Each of these analysis locations is associated with a continuous record of streamflows and a location where streamflow impacts are accumulated (Table 2).

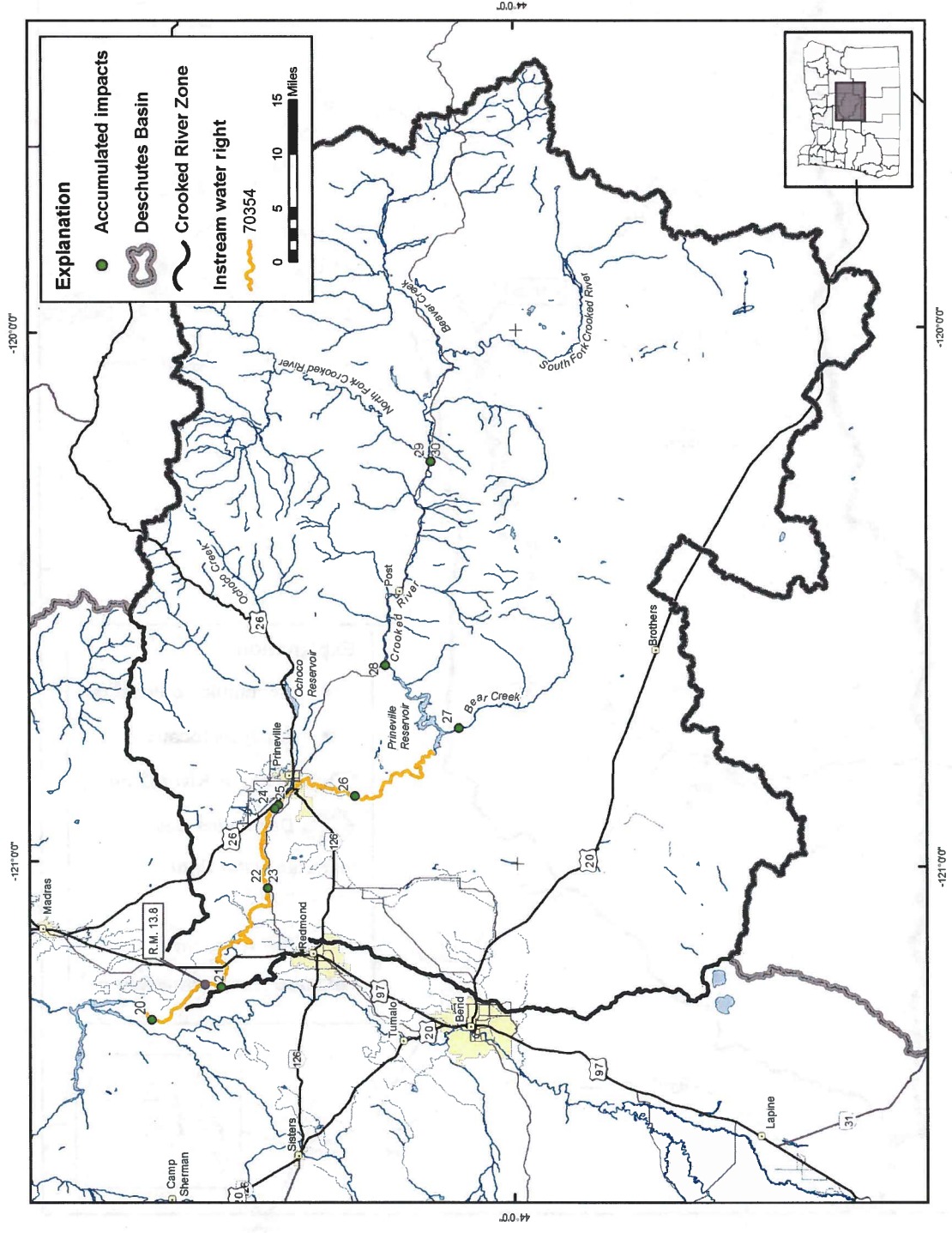
The percent of time in-stream flow requirements are met is determined by comparing the historic streamflow to the in-stream flow requirement. The existing or baseline condition is based on the actual streamflow record. The impacted condition is based on the actual streamflow record modified by the accumulated streamflow impacts. Whether an in-stream requirement is met is determined on a daily basis (using *mean* daily flows as the basis for comparison) and is reported as the percent of days the in-stream flow requirements are met both monthly and annually.

Water years 1966 to 1995 were chosen to represent the baseline condition. This time period is after completion of all reservoirs and prior to any ground water withdrawals subject to regulation under the State Scenic Waterway Act. The historic streamflows are adjusted for effects of new groundwater uses and mitigation activities *as though* the uses and mitigation

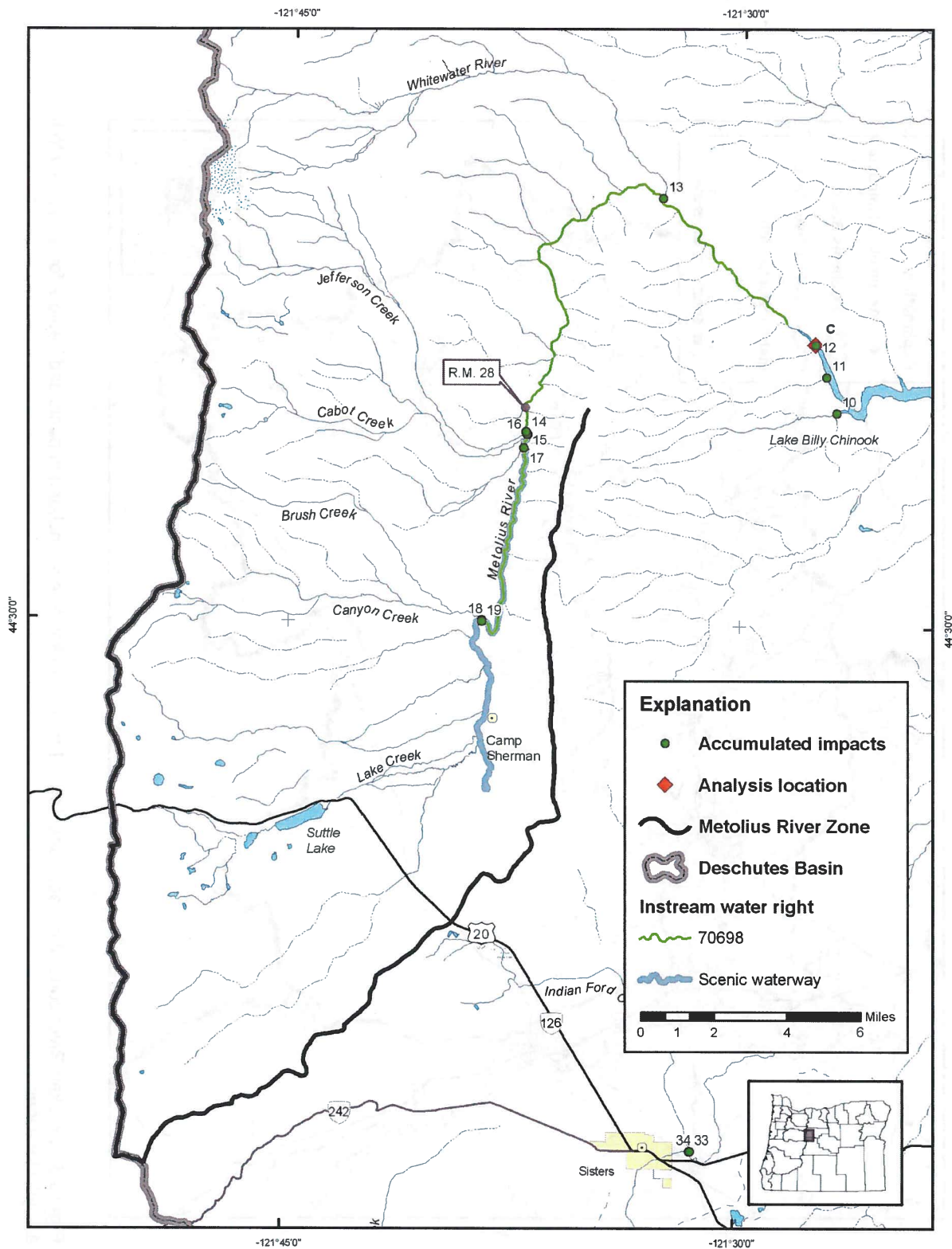


**Figure 2.** General zone of impact. See Table 1 for a map key to accumulated impacts and Table 2 for a map key to the analysis locations.

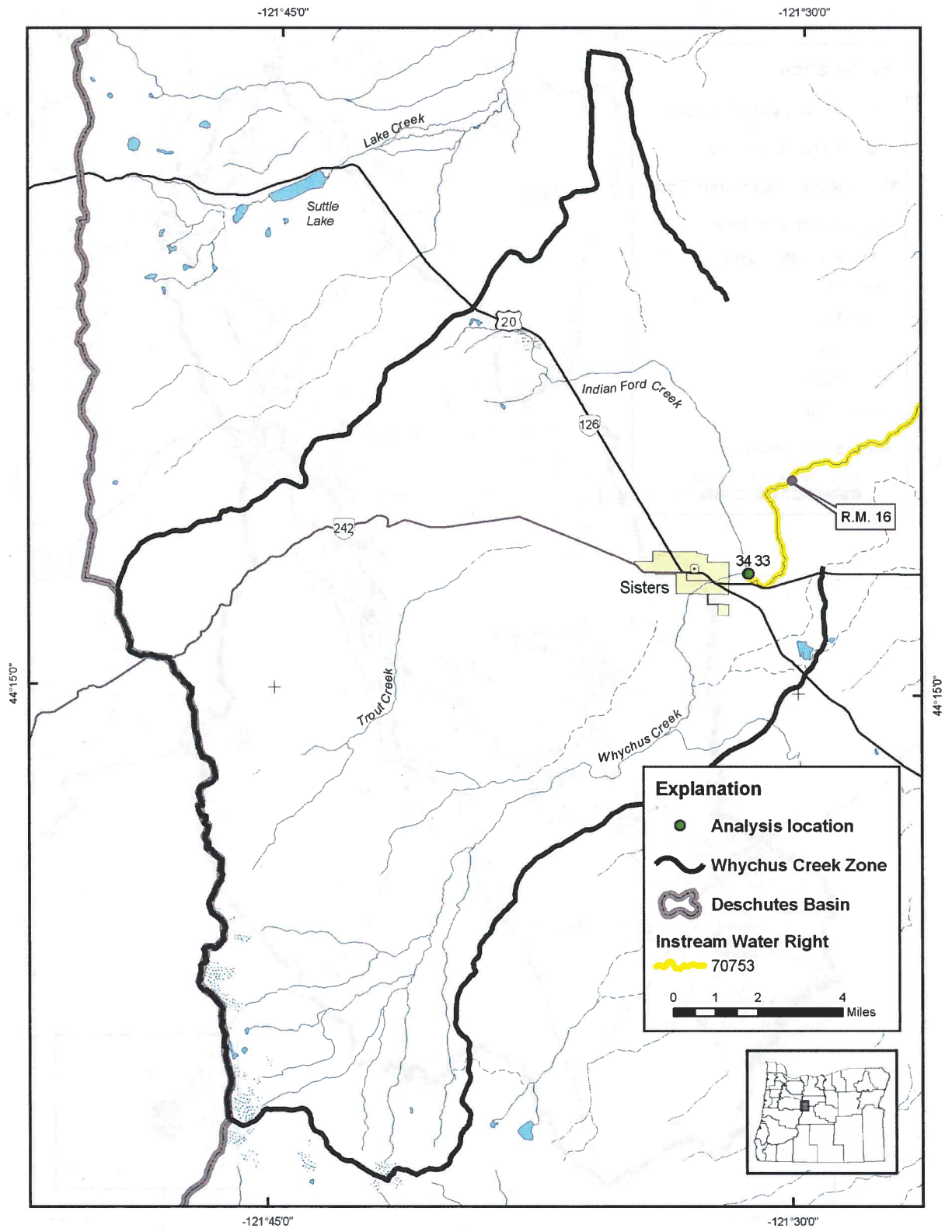




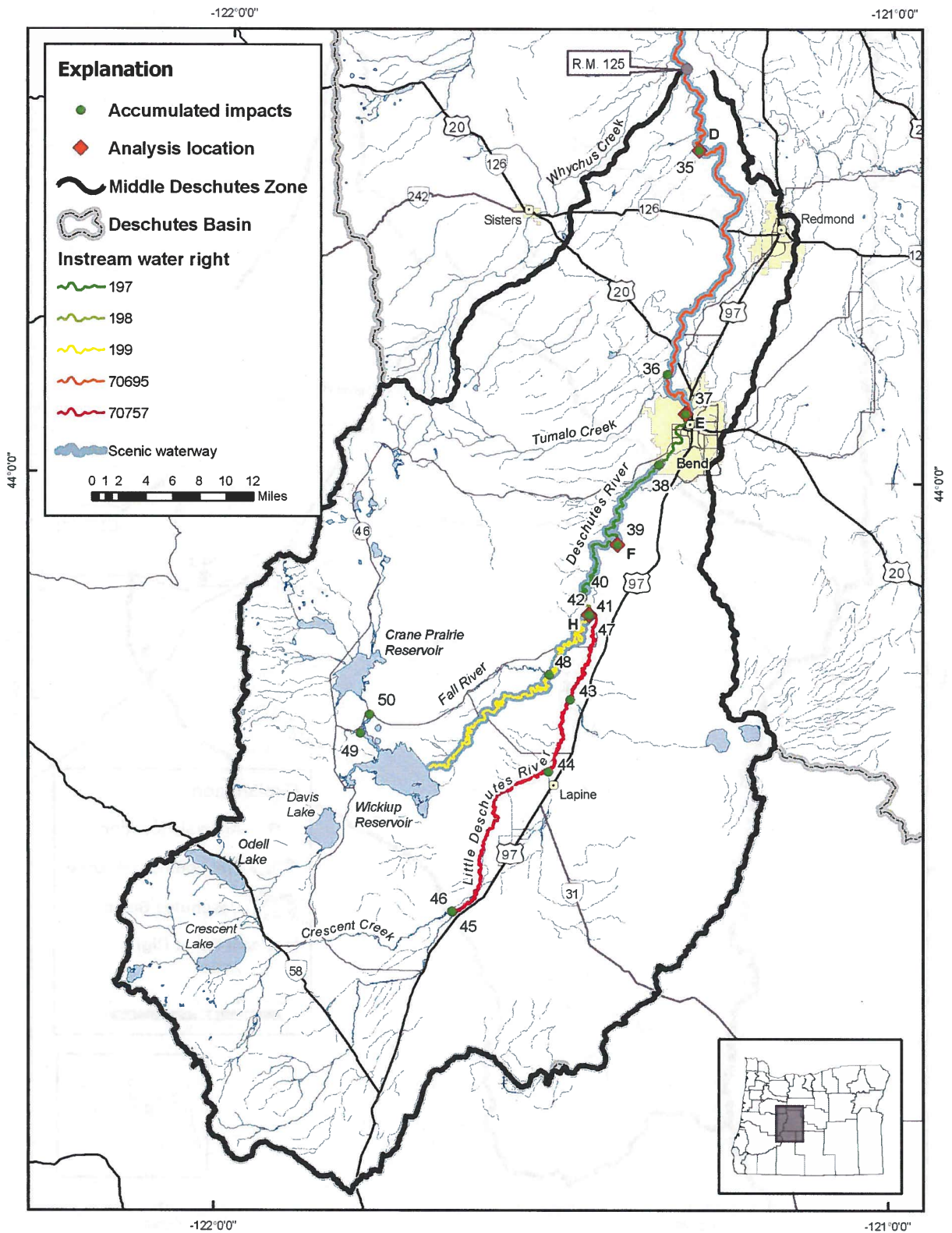
**Figure 3.** Crooked River zone of impact. See Table 1 for a map key to accumulated impacts and Table 2 for a map key to the analysis locations.



**Figure 4.** Metolius River zone of impact. See Table 1 for a map key for accumulated impacts and Table 2 for a map key to the analysis locations.



**Figure 5.** Whychus Creek zone of impact. See Table 1 for a map key for accumulated impacts and Table 2 for a map key to the analysis locations.



**Figure 6.** Middle Deschutes River zone of impact. See Table 1 for a map key for accumulated impacts and Table 2 for a map key to the analysis locations.

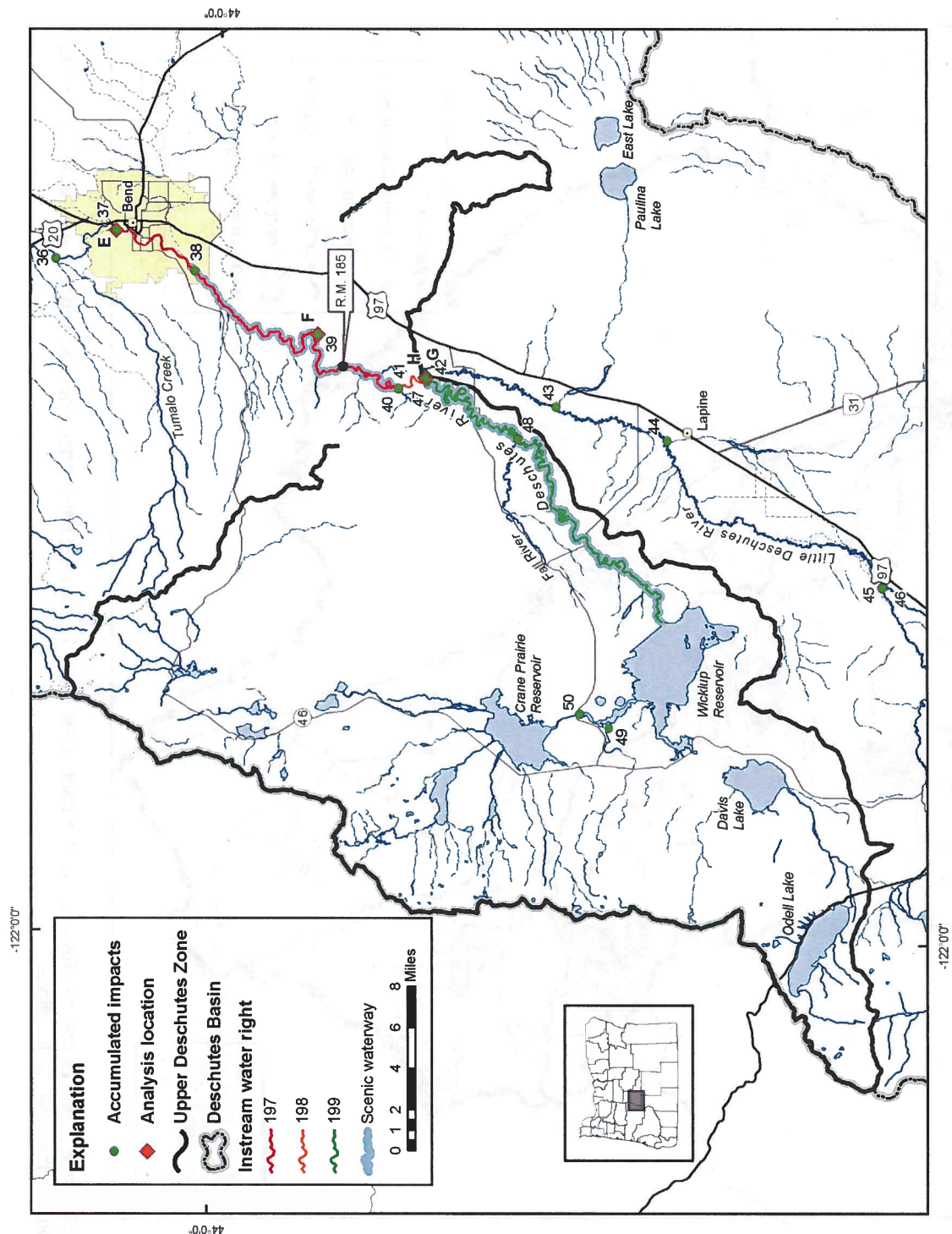


Figure 7. Upper Deschutes River zone of impact. See Table 1 for a map key for accumulated impacts and Table 2 for a map key to the analysis locations.

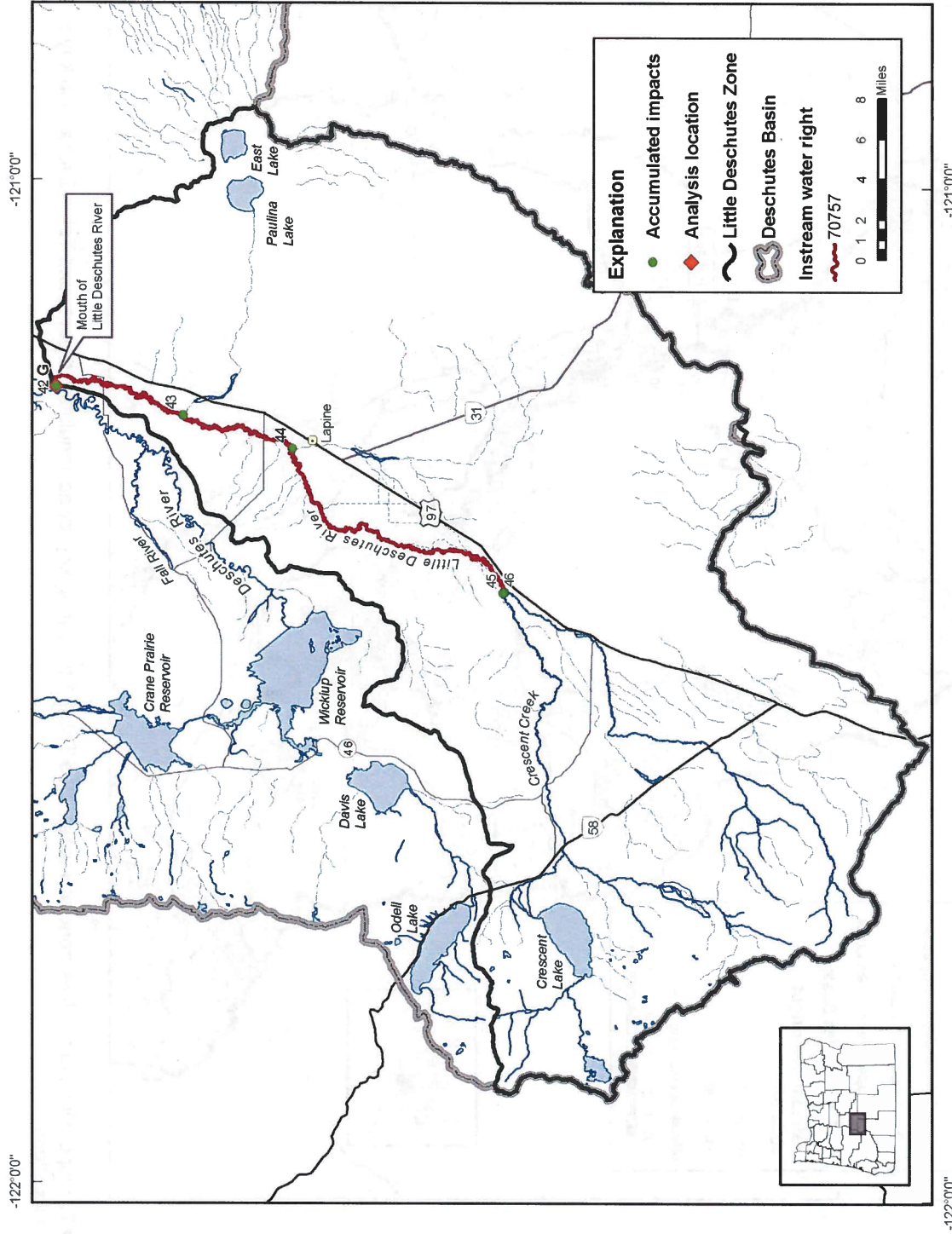


Figure 8. Little Deschutes River zone of impact. See Table 1 for a map key for accumulated impacts and Table 2 for a map key to the analysis locations.

activities were in place, fully developed and fully realized throughout the period of record.

The effects of groundwater withdrawals and mitigation activities are measured by the change in the percentage of time the mean daily flows exceed in-streamflow requirements, monthly and annually. As an example, Tables 5 and 7 show the baseline condition for the amount of time the scenic waterway flows are met in the Deschutes River below Pelton Dam. Examples showing the impacts of a mitigation project and of a groundwater withdrawal on streamflow are given in Appendices A and B, respectively.

## Mitigation

Mitigation activities are expected to “offset” the effects of new allocations of groundwater on surface water. In practice, groundwater use will be linked to specific mitigation projects. For this model, however, mitigation projects and groundwater use are considered as independent of one another with mitigation projects generating credits and groundwater use generating debits.

Four types of mitigation projects are identified under the mitigation rules: 1) in-stream leases and transfers, 2) allocation of conserved water, 3) aquifer storage and recovery, and 4) allocation of existing stored water to in-stream use. These mitigation projects use existing methods to create water rights; the methods were not developed as part of the mitigation program. All of these methods have specific requirements defined in statute and rule and must result in a quantity of water that is legally protected in-stream. To date, only in-stream leases and transfers have been used to establish mitigation credits.

Volumetrically, leases and transfers of existing water rights to in-stream provide ‘drop for drop’ mitigation. A transfer puts the same volume of water in-stream as is allowed to be removed from streamflow by associated groundwater withdrawals. Overall, consumptive use in the basin remains the same. A lease, however, puts twice the water in-stream as is allowed to be removed by associated groundwater withdrawals. Overall, consumptive use in the basin is reduced.

The other three types of mitigation projects decrease streamflow by increasing consumptive use overall in the basin. In these cases, new consumptive uses of water are allowed without the compensating retirement of an existing water right. Note, however, that a decrease in streamflow does not necessarily mean a decrease in the frequency an in-stream flow requirement is met. If the new allocations impact streamflow at times when sufficient water is present to meet the in-stream demands, the frequency will not be diminished.

Mitigation projects affect streamflow both above and below an area of groundwater discharge or zone of impact. All four cases of mitigation projects either modify existing diversions from surface flow or create new diversions. These additions to or subtractions from streamflow affect all stream reaches downstream whether above or below the area of discharge.

**Table 7.** Percent of days the in-stream flow requirement is met by month in the Deschutes River below Pelton Dam (Gaging Station 14092500) for the period, water years 1966 to 1995.

Month	Percent of days for each month for all years	Average number of days per month for all years
1	64.7	20
2	63.0	18
3	67.8	21
4	71.4	21
5	58.8	18
6	55.6	17
7	41.0	13
8	98.2	30
9	66.8	20
10	81.1	25
11	97.2	29
12	66.1	21
<b>Annual</b>	<b>69.3</b>	<b>253</b>

All of the mitigation projects except allocation of existing stored water also affect groundwater discharge. These effects are realized only downstream of the affected zones of impact.

The first type of mitigation project, in-stream leases and transfers, is discussed in detail in Appendix A. Both the conceptual model and the mathematical model are discussed. An example calculation is also described.

For the other three types of mitigation projects, further discussion is not possible at this time. As this report is being written, the ways in which these types of mitigation might be implemented have not been fully determined. When the exact terms are known in each case, an addendum to this report will be written describing the implementation of the mitigation project along with an example calculation to illustrate the streamflow impacts.

## Groundwater Withdrawals

The impacts of groundwater withdrawals are simply accounted for in the model. The consumptive part of the withdrawal is debited from streamflow downstream from the zone of impact. Two simplifying assumptions are made regarding this accounting: 1) impacts are distributed uniformly over the year and 2) impacts are realized only downstream of the zone of impact.

First, although the withdrawals, and hence the consumptive use, likely vary seasonally, we assume the temporal variation is completely attenuated by passage through the affected groundwater system. In the model, then, the impacts are uniformly distributed over the year. This assumption is consistent with the observed behavior of the regional ground-water flow system in the Deschutes Basin (Gannett and others, 2001).

Second, for a groundwater withdrawal, the pressure response that may propagate up gradient with possible upstream effects is ignored, and it is assumed that all impacts on groundwater discharge to streamflow are downstream of the zone of impact. Gannett and Lite (2004) show that upstream effects are generally small compared to downstream effects.

Groundwater withdrawals are discussed in detail in Appendix B. Both the conceptual model and the mathematical model are discussed. An example calculation is also provided.

## Zone of Impact Determination

A zone of impact determination is required wherever a groundwater withdrawal or a mitigation project impacts either a local or the regional groundwater system. A groundwater withdrawal always requires a zone of impact determination. A mitigation project may or may not require a determination. For example, a determination is required for mitigation projects involving aquifer storage, but not for those involving allocation of existing stored water.

For mitigation projects involving leases, transfers and allocation of conserved water, a zone of impact determination is required in most cases, but not all. Usually, a water use is not entirely consumptive, and some of the originally diverted water is returned to streamflow, most often by way of groundwater (See Cooper, 2002, for further discussion). Where there are return flows, and they are by way of groundwater, a zone of impact determination is required.

In a few cases, the water use may be entirely consumptive with no return flows, or if not entirely consumptive, the return flows are by means other than groundwater (e.g., a sewage outfall discharging directly to surface water). In these cases, groundwater is unaffected, and a zone of impact determination is not required.

To date, all mitigation projects have been for an in-stream lease or transfer of a water right originally allocated for irrigation. All have required a zone of impact determination.

Where required, the determination of the correct zone of impact is made by a separate hydrologic analysis conducted by OWRD staff. Based on this determination, the mitigation model assigns the impact to the correct zone. For some mitigation projects, more than one zone of impact may be affected. In these cases, the effects are distributed among the affected zones of impact. Groundwater withdrawals are assumed to affect only one zone of impact. The



determination of the zone of impact for a mitigation project is described in Appendix C, and the determination of the zone of impact for a groundwater withdrawal is described in Appendix D.

## Groundwater Rights with the 7J Condition

Between 1995 and 2000, 193 groundwater rights were issued with a condition allowing regulation if the use was found to cause a measurable reduction in streamflow. This condition is commonly referred to as the 7J condition. Measurable reduction is defined by the Scenic Waterway Act as a reduction in streamflows within the scenic waterway in excess of one percent of the average daily flows or one cubic foot per second, whichever is less. In the Deschutes Basin, the threshold is one cubic foot per second in all cases.

Hydrologic studies conducted over the past century, including those of Russell (1905), Stearns (1932), Sceva (1960, 1968), and Gannett and others (2001), provide a preponderance of evidence to support a finding that groundwater use could cause a measurable reduction in scenic waterway flows. Water rights with the 7J condition are now subject to possible regulation. However, pursuant to the new Deschutes Ground Water Mitigation rules, these ground water right holders have the option of providing mitigation to avoid future regulation.

Water rights with the 7J condition are not accounted for in the model as they are subject to regulation. If the permit holders obtain mitigation credits to offset their water use, the rights will not be subject to regulation. If mitigation is acquired for any of these rights, the associated water use impacts and the new mitigation will be entered into the accounting.

## Assumptions of the Model

This section summarizes the assumptions made related to model development and implementation.

The first of these assumptions concerns groundwater recharge and discharge. In the model, water is added to the regional or to a

local groundwater system by way of return flows. Water is subtracted by way of groundwater withdrawals. In either case, the effects on streamflow of these additions or subtractions occur at the zone of impact associated with the groundwater system. Although the additions and subtractions may vary seasonally, the model assumes that any seasonality is completely attenuated by passage through the groundwater system, that is, the effects on discharge at the zone of impact are distributed uniformly in time. It is also assumed that groundwater withdrawals impact discharge to streamflow only downstream of the zone of impact.

We make two assumptions about the impact of Lakes Billy Chinook and Simtustus on flows in the lower Deschutes River. First, we assume that mitigation projects do not impact the operation of Round Butte and Pelton Dams. Changes in streamflow upstream of Billy Chinook are passed through to the Deschutes River below Pelton Dam. Second, we assume future changes in operation of the Round Butte and Pelton Dams are independent of any changes in streamflow due to mitigation projects.

Finally, we assume steady state conditions, that mitigation projects and groundwater withdrawals are fully developed and that their effects downstream are fully realized. Please note that only permitted groundwater withdrawals backed by valid credits are included in the model. Although a municipal water right that is allowed incremental development may be permitted in total, each increment is included in the model only as credits are acquired to back it.

Other assumptions are made that are specific to the type of mitigation involved. For leases and transfers, these additional assumptions are given in Appendix A. Assumptions specific to the other types of mitigation projects will be discussed when the addendums to this report are written that describe the other types of mitigation projects.

## Shortcomings of the Model

The model has at least three shortcomings.

First, the model does not account for streamflow travel times and attenuation<sup>4</sup> of peak flows. This shortcoming would affect streamflows from water leased or transferred in-stream if the releases were variable, e.g., proportional to existing streamflow. However, in-stream transfers are constant over long periods. For example, an in-stream transfer might be set for 3 cfs from April to June, 5 cfs from July to August and 2 cfs in September and October. When streamflows remain constant, the effects of travel time and attenuation are small.

Second, the model does not account for storage effects due to Lakes Billy Chinook and Simtustus. The model assumes that changes in streamflow due to leases or transfers of water in-stream or due to new diversions for aquifer storage are simply passed through the lakes without affecting operation of the Round Butte and Pelton Dams.

This assumption does not claim that the reservoir has no effect on streamflows passing through it; the reservoir, in fact, *does* affect flows. These effects are accounted for in the streamflow record below the reservoir. The assumption only claims that streamflow changes due to mitigation projects upstream of the reservoir would not have caused a change in reservoir operation.

Apart from their operation, the reservoirs could attenuate changes in streamflow simply because they are a wide spot in the river. As already noted, however, in-stream releases due to leases and transfers will be constant for long periods and attenuation should not be a factor. On the other hand, diversions for aquifer storage are not likely to be uniform. The model will not account for smoothing of these decreases in streamflow.

Third, not every in-stream flow water requirement could be evaluated for impacts due

to mitigation activities. Only those in-stream water right reaches with a gaging station in operation from 1966 to 1995 were candidates for evaluation.

## References

- Cooper, RM. 2002. Determining Surface Water Availability in Oregon. Open File Report SW 02 – 002. Oregon Water Resources Department, Salem, Or. 57 p.
- Gannett, M.W., Lite, K.E., Jr., Morgan, D.S., and Collins, C.A., 2001, Ground-water hydrology of the upper Deschutes Basin, Oregon: U.S. Geological Survey Water-Resources Investigations Report 00-4162, 78 p.
- Gannett, M.W., and Lite, K.E., Jr., 2004, Simulation of regional ground-water flow in the upper Deschutes Basin, Oregon: U.S. Geological Survey Water-Resources Investigations Report 03-4195, 84 p.
- Russell, I.C., 1905, Geology and water resources of central Oregon: U.S. Geological Survey Bulletin 252, 138 p.
- Sceva, J.E., 1960, A brief description of the ground water resources of the Deschutes River Basin, Oregon: Oregon State Engineer [now Oregon Water Resources Department], Salem, Oregon, 55 p.
- Sceva, J.E., 1968, Liquid waste disposal in the lava terrane of central Oregon: U.S. Department of the Interior, Federal Water Pollution Control Administration, Technical Projects Branch Report No. FR-4, 66 p. plus a 96 page appendix.
- Stearns, H.T., 1931, Geology and water resources of the middle Deschutes River Basin, Oregon, U.S. Geological Survey Water-Supply Paper 637–D, 220

---

<sup>4</sup> Due to in-channel and out-of-bank storage and friction losses, peak streamflows are reduced in magnitude (attenuated) as they travel downstream.

## Appendix A - Leases and Transfers

In this case, a water right for an out of stream consumptive use is leased or transferred to an in-stream water right. The water assigned to in-stream use is legally protected from diversion by downstream users with junior priority dates. This increase in streamflow mitigates for streamflow lost to groundwater withdrawals.

By annual volume, the amount of water moved in-stream is equal to the allowed diversion for on-farm use (excludes transmission losses) under the old water right. The lease or transfer specifies the amount to be moved in-stream, the distribution of the in-stream flow requirements over the year, and the river reaches where the requirements are applied. Table A-1 gives an example of an in-stream lease. Note that the diversion (DV) is equal to the return flow (RF) plus the consumptive use (CU):  $DV = RF + CU$ . This lease is used later in an example calculation to show its impact on streamflow.

To compensate for transmission losses, many water uses in the Deschutes Basin divert significantly more than is required for on-farm use. These transmission losses may account for nearly half the diversion. When one of these uses is transferred or leased in-stream, the transmission losses are not included. As the use is retired, the water formerly diverted for transmission losses is left in-stream, but is not protected by an in-stream water right and is available for diversion by downstream users. Neither the fate of this water nor its impact on streamflow is considered in this analysis.

The lease or transfer specifies the amount of water to be protected in-stream and the river reaches to which it applies. When assigning values to the in-stream flow requirements for the various reaches, the reach containing the original point of diversion is always assigned an in-stream flow requirement equal to the original diversion less transmission losses. The reaches downstream may be assigned in-stream flow requirements equal to or less than that for the upper most reach, but never more than that. The amount of the in-stream flow requirement assigned to each reach depends on three factors: 1) the possibility of injury to downstream users, 2) the possibility of enlargement of the water right, and 3) the ability of the watermaster

to measure the increased flow. However, for a given lease or transfer, no reach may be assigned an in-stream flow requirement greater than that of the reach directly upstream.

Where a reach is protected by an in-stream flow requirement, it is assumed that the transferred water right has a priority date senior to other users on the stream reach that might otherwise access the water. In the model, then, streamflow for a reach is always increased by at least the amount of the in-stream flow requirement assigned to that reach. As will be explained next, in some cases, streamflow may be increased by more than the in-stream flow requirement.

If the assigned in-stream flow requirements decrease from one reach to the next downstream, or if a reach does not have an in-stream flow requirement, any unprotected water is assumed available for diversion. For each affected reach, the model asks whether users are present to divert the water.

Where users are not present, the model increases streamflow for the downstream reach in an amount equal to the increase in streamflow for the upstream reach. This is the case even though the increase in streamflow is greater than that specified by the in-stream flow requirement for the downstream reach.

Where users are present, the model assumes that all available water is diverted. In this case, the increase in streamflow for the downstream reach is equal to its in-stream flow requirement. If the downstream reach has no in-stream flow requirement, the increase in streamflow is zero. Table A-2 gives examples showing the effect on streamflow of a change in in-stream flow requirement with and without the presence of users able to divert the unprotected water.

It is assumed that any groundwater affected by return flow from the original diversion eventually discharges to surface water at the specified zone of impact. Before the lease or transfer, the groundwater discharge included the return flow. After the lease or transfer, the diversion is no longer made, and the return flow is no longer part of the groundwater discharge, that is,

**Table A-1.** An example of an in-stream transfer showing the amount diverted annually, the consumptive use and the return flows associated with the original water right, the seasonal distribution of the in-stream flow requirements, and the stream reaches where the requirements are applied.

<b>Irrigated Acres</b>	<b>Duty</b>	<b>Transmission Loss</b>
100 acres	9.91 acre-feet per acre	45 percent

<b>Component of Total Diversion</b>	<b>Annual Volume (acre-feet)</b>	<b>Comment</b>
Volume of water transferred in-stream (DV)	545	Equal to the diversion of the original water right for on-farm use (excludes transmission losses).
Consumptive use associated with the original water right (CU)	169	Assumes a consumptive use of 1.69 acre-feet per acre.
Return flows associated with the original water right (RF)	376	Continuous rate: 0.52 cfs
Transmission Losses	446	Neither the fate of this water nor its impact on streamflow is considered in this analysis.

	<b>Season</b>	<b>Maximum Rate (cfs/acre)</b>	<b>In-stream Flow Requirement (cfs)</b>
<b>Seasonal distribution of the in-stream flow requirements</b>	Apr 1 to May 1	1/80 <sup>th</sup>	0.690
	May 1 to May 15	1/60 <sup>th</sup>	0.920
	May 15 to Sep 15	1/32.4 <sup>th</sup>	1.700
	Sep 15 to Oct 1	1/60 <sup>th</sup>	0.920
	Oct 1 to Nov 1	1/80 <sup>th</sup>	0.690

<b>Stream reaches where the in-stream flow requirements are applied</b>	<b>All reaches from the COID North Canal diversion to Lake Billy Chinook</b>	
	<b>Watershed ID#</b>	<b>Watershed Name</b>
	197	Deschutes River above Tumalo Creek
	30530112	Deschutes River above Buckhorn Canyon
	70695	Deschutes River above Lake Billy Chinook

**Table A-2.** Examples showing the effect on streamflow of a change in in-stream flow requirement with and without the presence of users able to divert the unprotected water.

In-stream Flow Requirement			Change in Streamflow	
Upstream Reach	Downstream Reach	Users?	Upstream Reach	Downstream Reach
cfs			cfs	
2.0	1.0	No	2.0	2.0
2.0	1.0	Yes	2.0	1.0
2.0	None	No	2.0	2.0
2.0	None	Yes	2.0	0.0

streamflow is decreased by the amount of the return flow. The actual net annual increase to streamflow below the zone of impact, then, is equal to the diversion minus the return flow, that is, the consumptive use of the original water right (recall that  $DV = RF + CU$ ). Note that the water transferred in-stream varies seasonally and that the water associated with the return flows is distributed uniformly over the year. Table A-3 gives examples showing the effect on streamflow of the loss of return flow with and without an in-stream flow requirement and with and without the presence of users able to divert any unprotected water.

The conceptual model for leases and transfers is shown in Figures A-1 and A-2. Figure A-1

shows the case where the original diversion is from the Deschutes River and the zone of impact is also on the Deschutes River. Figure A-2 shows the case where the original diversion is from the Deschutes River but the zone of impact is on the Crooked River. For each of these cases, two further cases are considered: A) before the lease or transfer with the original diversion still in place, and B) after the lease or transfer with the original diversion replaced by in-stream flow requirements. Not shown is the case where the original diversion is from the Crooked River and the zone of impact is also on the Crooked River. This case is essentially the same as the case where the diversion and the zone of impact are both on the Deschutes River. Some mitigation projects have diversions that occur on the Deschutes River but the places of

**Table A-3.** Examples showing the effect on streamflow of the loss of return flow with and without an in-stream flow requirement and with and without the presence of users able to divert any unprotected water. The downstream reach is at the Zone of Impact.

Change in streamflow for the upstream reach	In-stream flow requirement for the downstream reach	Lost Return Flow	Users?	Change in streamflow for the downstream reach
cfs	cfs	cfs		cfs
2.0	2.0	1.3	No	0.7
2.0	2.0	1.3	Yes	0.7
2.0	1.0	1.3	No	0.7
2.0	1.0	1.3	Yes	-0.3
2.0	None	1.3	No	0.7
2.0	None	1.3	Yes	-1.3

use are such that multiple zones of impact are affected - sometimes involving both the Crooked and Deschutes Rivers. The example calculation to follow considers such a case. The numerical

model, the model assumptions, and the required model inputs are given in Tables A-4, A-5, and A-6 respectively.

**Table A-4.** The numerical model for a transfer or lease.

---

**Increase streamflow due to in-stream flow requirements:**

For the reach at the point of diversion:

$$\Delta SF_n = DV$$

Then beginning at the next reach downstream, DO the following for each reach below that in downstream order:

```
if ISWRi+1 > ISWRi then
  if USERS then
     $\Delta SF_i = \Delta SF_i + ISWR_i$ 
  else
     $\Delta SF_i = \Delta SF_i + ISWR_{i+1}$ 
  end if
else
   $\Delta SF_i = \Delta SF_i + ISWR_i$ 
end if
end do
```

where ISWR<sub>i</sub> = in-stream flow requirement for reach i  
DV = diversion for the original water right  
 $\Delta SF_i$  = *change* in streamflow for reach i  
i = the reach number  
n = the number of reaches

**Decrease streamflow due to loss of return flow:**

For all reaches at and below the Zone of Impact, DO the following in downstream order:

```
If ISWRi > 0 then
   $\Delta SF_i = \Delta SF_i - RF$ 
end if
end do
```

---

**Table A-5.** Model assumptions for a transfer or lease.

---

The groundwater–surface water system is at steady state - mitigation activities are fully developed and their effects downstream are fully realized.

Return flows directly recharge either the regional or a local groundwater system that discharges to one of the zones of impact.

The change in streamflow for a reach can be no more than the change in streamflow for the reach upstream.

Unprotected water is assumed to be entirely diverted when users are present. It is further assumed there are no return flows from these diversions.

Unprotected water is assumed to be passed downstream when users are not present even when there is not an ISWR to protect it or if there is an ISWR that does not protect it in full.

If no users and  $ISWR_i = 0$  or  $ISWR_{i+1} > ISWR_i$ , then  $\Delta SF_i = ISWR_{i+1}$

Mitigation activities do not impact the operation of Round Butte and Pelton Dams. Changes in streamflow upstream of Billy Chinook are passed through to the Deschutes River below Pelton Dam.

Future changes in operation of the Round Butte and Pelton Dams are independent of any changes in streamflow due to mitigation activities.

---

**Table A-6.** The required model input for a transfer or lease.

---

Location of the point of diversion of the original water right.

DV and CU, the original diversion and its associated consumptive use.

- $RF = D - CU$

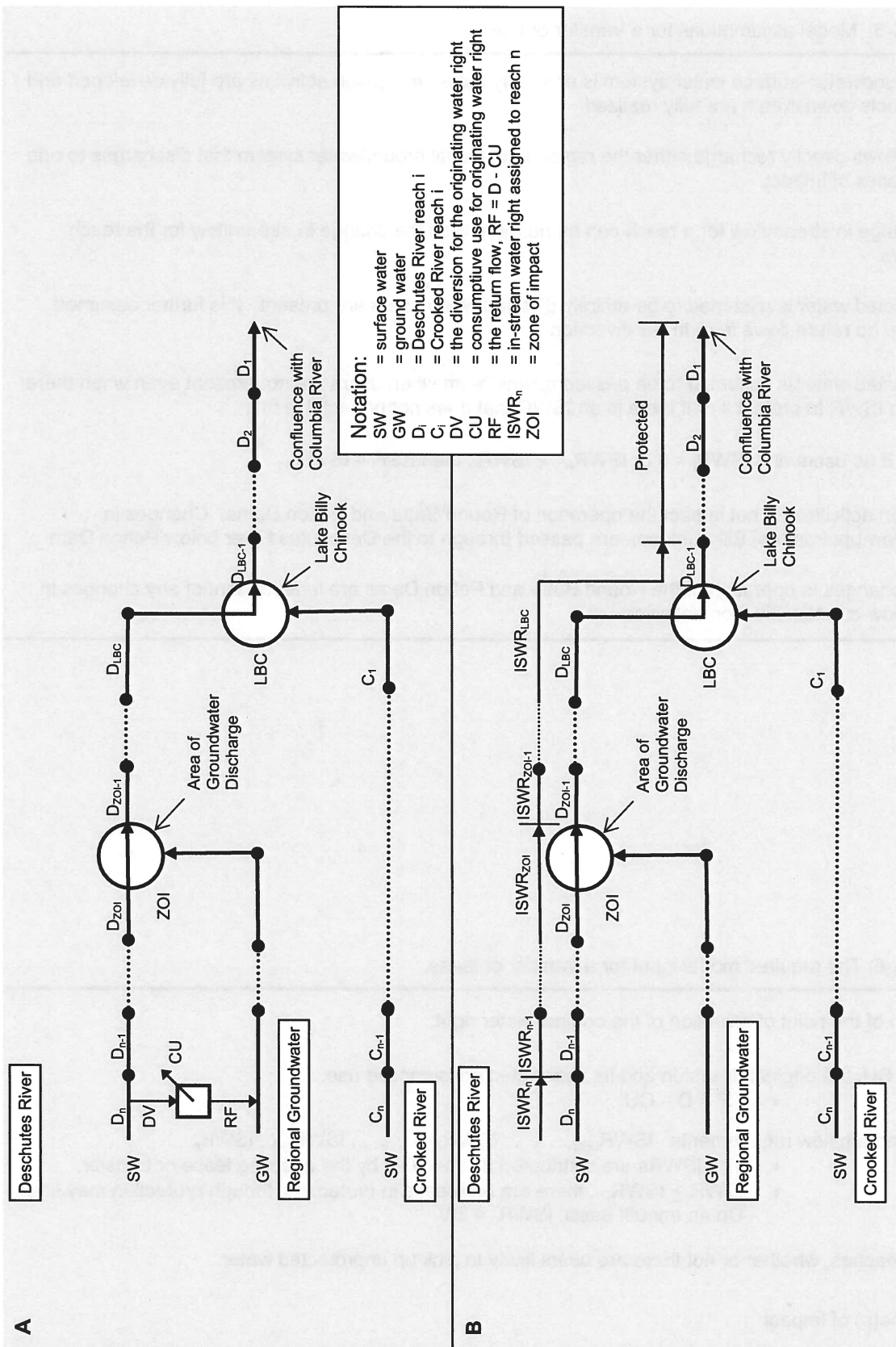
The in-stream flow requirements:  $ISWR_{LBC}, \dots, ISWR_{ZOI}, \dots, ISWR_{n-1}, ISWR_n$

- The ISWRs are distributed as specified by the enabling lease or transfer.
- $ISWR_i \geq ISWR_{i-1}$ , there are no breaks in protection, though protection may end. On an annual basis,  $ISWR_n = DV$ .

For all reaches, whether or not there are users likely to pick up unprotected water.

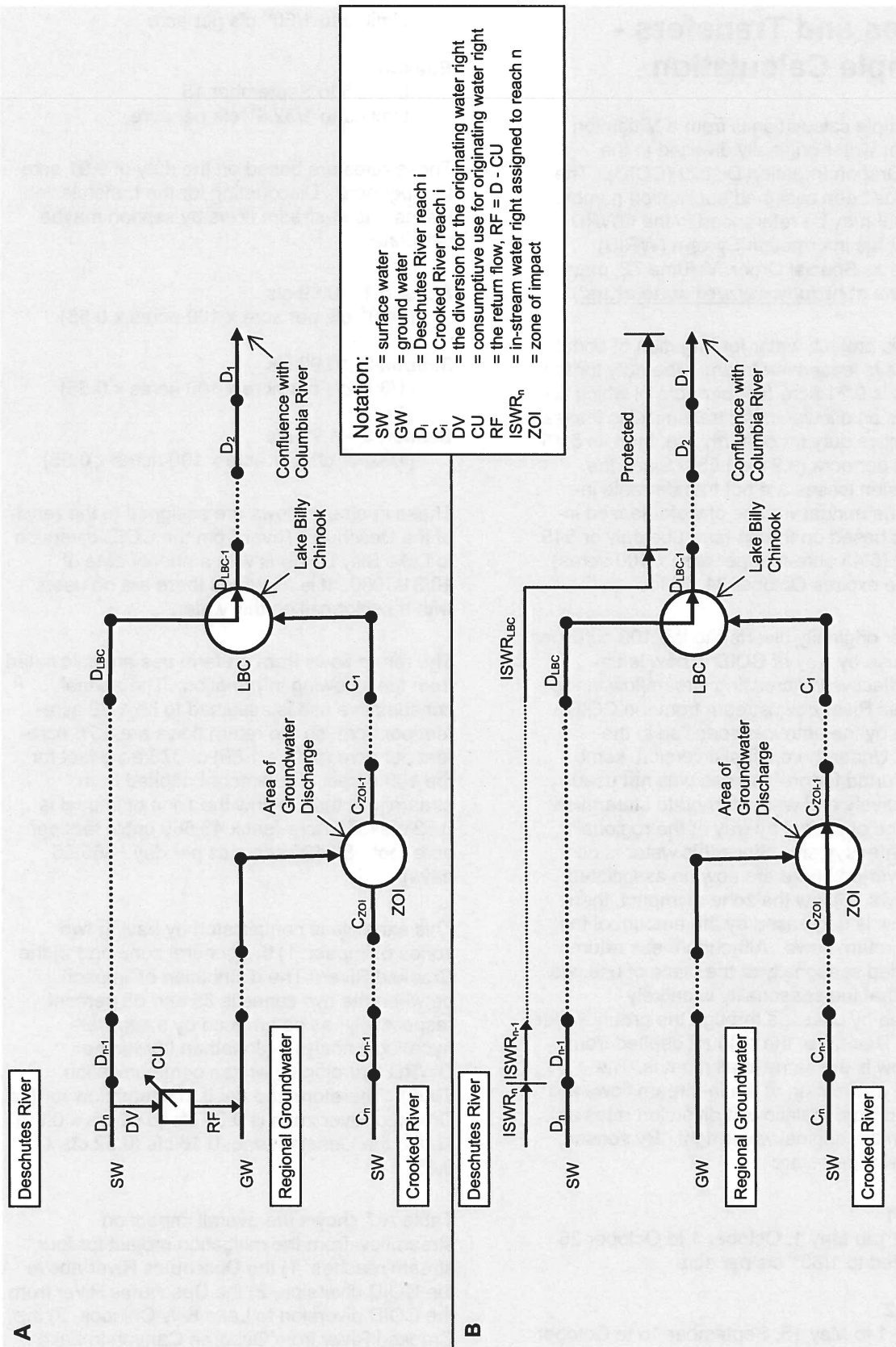
The Zone(s) of Impact

---



**Figure A-1.** Where the diversion and the zone of impact are both on the Deschutes River, showing the conceptual models for the cases (A) before and (B) after implementation of a lease or transfer.





**Figure A-2.** Where the diversion is on the Deschutes River and the zone of impact is on the Crooked River, showing the conceptual models for the cases (A) before and (B) after implementation of a lease or transfer.

## Leases and Transfers - Example Calculation

The example calculation is from a Mitigation Project for water originally diverted to the Central Oregon Irrigation District (COID). The project has been assigned application number IL-826, but may be referenced in the OWRD Water Rights Information System (WRIS) database as Special Order, Volume 72, page 282 (online at <http://www.wrd.state.or.us/>).

Under this project, water for irrigation of about 100 acres is leased in-stream. The duty for this diversion is 9.91 acre-feet per acre of which 45 percent is an allowance for transmission losses. The effective duty for on-farm use, then, is 5.45 acre-feet per acre ( $9.91 \times 0.55$ ). Since the transmission losses are not transferrable in-stream, the annual volume of water leased in-stream is based on the on-farm use only or 545 acre-feet ( $5.45 \text{ acre-feet per acre} \times 100 \text{ acres}$ ). The lease expires October 31, 2011.

The water originally diverted to the 100 acres for on-farm use by way of COID is now left in-stream effectively increasing streamflow in the Deschutes River downstream from the COID diversion by the amounts specified in the transfer. Under the original diversion, some water diverted for on-farm use was not used consumptively and was returned to streamflow at the zone of impact by way of the regional groundwater system. Since this water is no longer diverted, there are now no associated return flows. Below the zone of impact, then, streamflow is decreased by the amount of the previous return flows. Although these return flows varied seasonally at the place of use, we assume that the seasonality is entirely attenuated by passage through the groundwater system. Therefore, the amount debited from streamflow is the same in all months. The seasonal distribution of the in-stream flows are calculated from the allowed diversion rates as defined in the original water right. By season, the diversion rates are

### Season 1

April 1 to May 1, October 1 to October 26  
Limited to  $1/80^{\text{th}}$  cfs per acre

### Season 2

May 1 to May 15, September 15 to October

Limited to  $1/60^{\text{th}}$  cfs per acre

### Season 3

May 15 to September 15  
Limited to  $1/32.4^{\text{th}}$  cfs per acre

These rates are based on the duty of 9.91 acre-feet per acre. Discounting for the transmission losses, the in-stream flows by season maybe calculated:

### Season 1 – 0.69 cfs

( $1/80^{\text{th}}$  cfs per acre  $\times$  100 acres  $\times$  0.55)

### Season 2 – 0.92 cfs

( $1/60^{\text{th}}$  cfs per acre  $\times$  100 acres  $\times$  0.55)

### Season 3 – 1.70 cfs

( $1/32.4^{\text{th}}$  cfs per acre  $\times$  100 acres  $\times$  0.55)

These in-stream flows are assigned to the reach of the Deschutes River from the COID diversion to Lake Billy Chinook with a priority date of 10/31/1900. It is assumed there are no users with a senior call on this water.

The return flows from on-farm use are calculated from the following information. The annual consumptive use is assumed to be 1.69 acre-feet per acre, so the return flows are 3.76 acre-feet per acre ( $5.45 - 1.69$ ) or 376 acre-feet for the 100 acres. The amount debited from streamflow, then, below the zone of impact is 0.52 cfs ( $376 \text{ acre-feet} \times 43,560 \text{ cubic feet per acre-foot} / 86,400 \text{ seconds per day} / 365.25 \text{ days}$ ).

This example is complicated by having two zones of impact: 1) the general zone and 2) the Crooked River. The distribution of 'impact' between the two zones is 35 and 65 percent, respectively, as determined by a separate hydrologic analysis (Jonathan LaMarche, OWRD hydrologist, written communication, 2008). Therefore, the debit to streamflow for the Crooked River zone is 0.34 cfs ( $0.52 \text{ cfs} \times 0.65$ ) and to the General zone, 0.18 cfs ( $0.52 \text{ cfs} \times 0.35$ ).

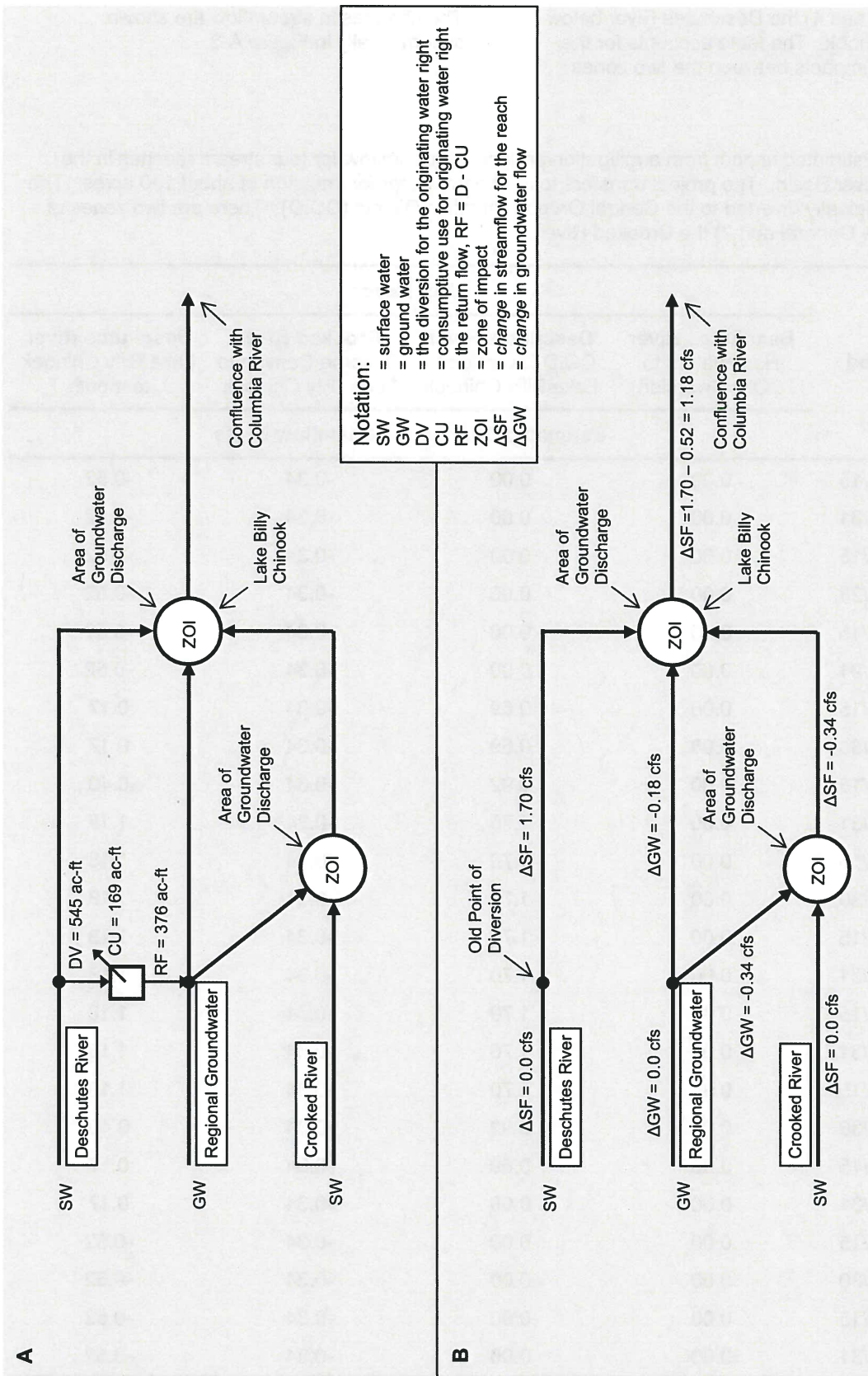
Table A-7 shows the overall impact on streamflow from the mitigation project for four stream reaches: 1) the Deschutes River above the COID diversion, 2) the Deschutes River from the COID diversion to Lake Billy Chinook, 3) the Crooked River from Osborne Canyon to Lake

Billy Chinook, and 4) the Deschutes River below Lake Billy Chinook. The table accounts for the distribution of impacts between the two zones.

The changes in streamflow are shown schematically in Figure A-3.

**Table A-7.** Estimated impact from a mitigation project on streamflow for four stream reaches in the Deschutes River Basin. The project transfers to in-stream, water for irrigation of about 100 acres. The water was originally diverted to the Central Oregon Irrigation District (COID). There are two zones of impact: 1) the General and 2) the Crooked River.

Time Period	River Reach			
	Deschutes River Headwaters to COID Diversion	Deschutes River COID Diversion to Lake Billy Chinook	Crooked River Osborne Canyon to Lake Billy Chinook	Deschutes River Lake Billy Chinook to mouth
Estimated Change in Streamflow in cfs				
01/01 to 01/15	0.00	0.00	-0.34	-0.52
01/16 to 01/31	0.00	0.00	-0.34	-0.52
02/01 to 02/15	0.00	0.00	-0.34	-0.52
02/16 to 02/28	0.00	0.00	-0.34	-0.52
03/01 to 03/15	0.00	0.00	-0.34	-0.52
03/16 to 03/31	0.00	0.00	-0.34	-0.52
04/01 to 04/15	0.00	0.69	-0.34	0.17
04/16 to 04/30	0.00	0.69	-0.34	0.17
05/01 to 05/15	0.00	0.92	-0.34	0.40
05/16 to 05/31	0.00	1.70	-0.34	1.18
06/01 to 06/15	0.00	1.70	-0.34	1.18
06/16 to 06/30	0.00	1.70	-0.34	1.18
07/01 to 07/15	0.00	1.70	-0.34	1.18
07/16 to 07/31	0.00	1.70	-0.34	1.18
08/01 to 08/15	0.00	1.70	-0.34	1.18
08/16 to 08/31	0.00	1.70	-0.34	1.18
09/01 to 09/15	0.00	1.70	-0.34	1.18
09/16 to 09/30	0.00	0.92	-0.34	0.40
10/01 to 10/15	0.00	0.69	-0.34	0.17
10/16 to 10/31	0.00	0.69	-0.34	0.17
11/01 to 11/15	0.00	0.00	-0.34	-0.52
11/16 to 11/30	0.00	0.00	-0.34	-0.52
12/01 to 12/15	0.00	0.00	-0.34	-0.52
12/16 to 12/31	0.00	0.00	-0.34	-0.52



**Figure A-3.** A simplified schematic showing the change in streamflow for various reaches of the Deschutes and Crooked Rivers as a result of the in-stream lease given in the example. Case A shows the diversion prior to the lease. Case B shows the diversion after the lease is retired. Streamflow values are for July. See Table A-7.

# Appendix B - Groundwater Withdrawals

All groundwater debits are treated the same in the model. The consumptive use is distributed uniformly over the year and subtracted from surface water flows downstream of the zone of impact. Upstream of the zone of impact, there is no effect on stream flow.

The conceptual model for groundwater withdrawals is shown in Figures B-1 and B-2. Figure B-1 shows the case where the zone of impact is on the Deschutes River. Figure B-2 shows the case where the zone of impact is on the Crooked River. For each of these cases, two further cases are considered: A) before the groundwater withdrawal and B) after the groundwater withdrawal has been implemented. It is assumed that a groundwater withdrawal affects only one zone of impact.

Only permitted groundwater withdrawals backed by valid credits are included in the analysis. Although a municipal water right that is allowed incremental development may be permitted in total, each increment is included in the model only as credits are acquired to back it.

The numerical model, the model assumptions, and the required model inputs are given in Tables B-1, B-2 and B-3, respectively.

## Groundwater Withdrawal – Example Calculation

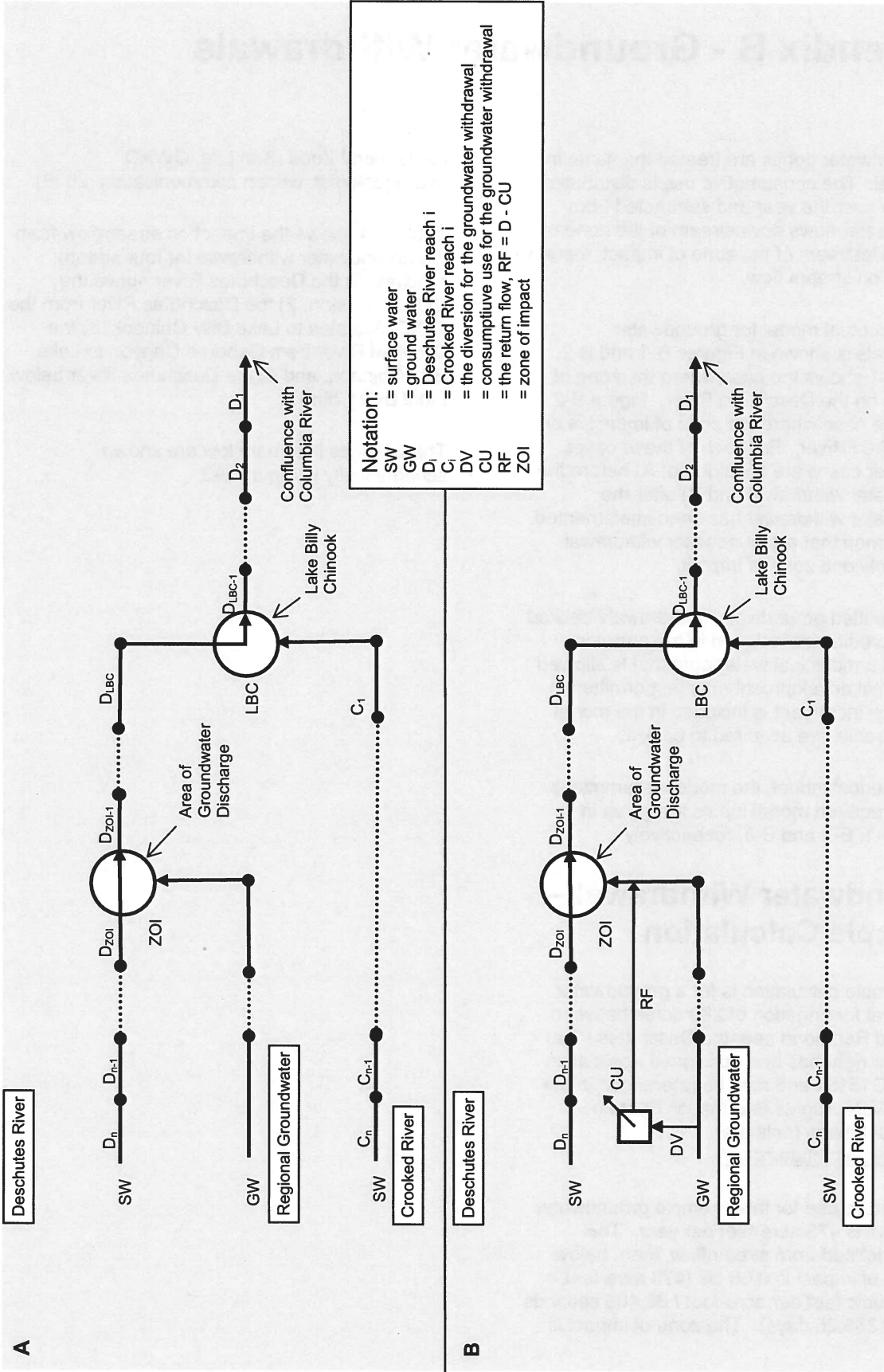
The example calculation is for a groundwater withdrawal for irrigation of 280 acres between Bend and Redmond near the Deschutes River. The water right has been assigned application number G15154 and may be referenced in the OWRD Water Rights Information System (WRIS) database (online at <http://www.wrd.state.or.us/>).

Consumptive use for this example groundwater withdrawal is 473 acre-feet per year. The amount debited from streamflow, then, below the zone of impact is 0.65 cfs (473 acre-feet x 43,560 cubic feet per acre-foot / 86,400 seconds per day / 365.25 days). The zone of impact is

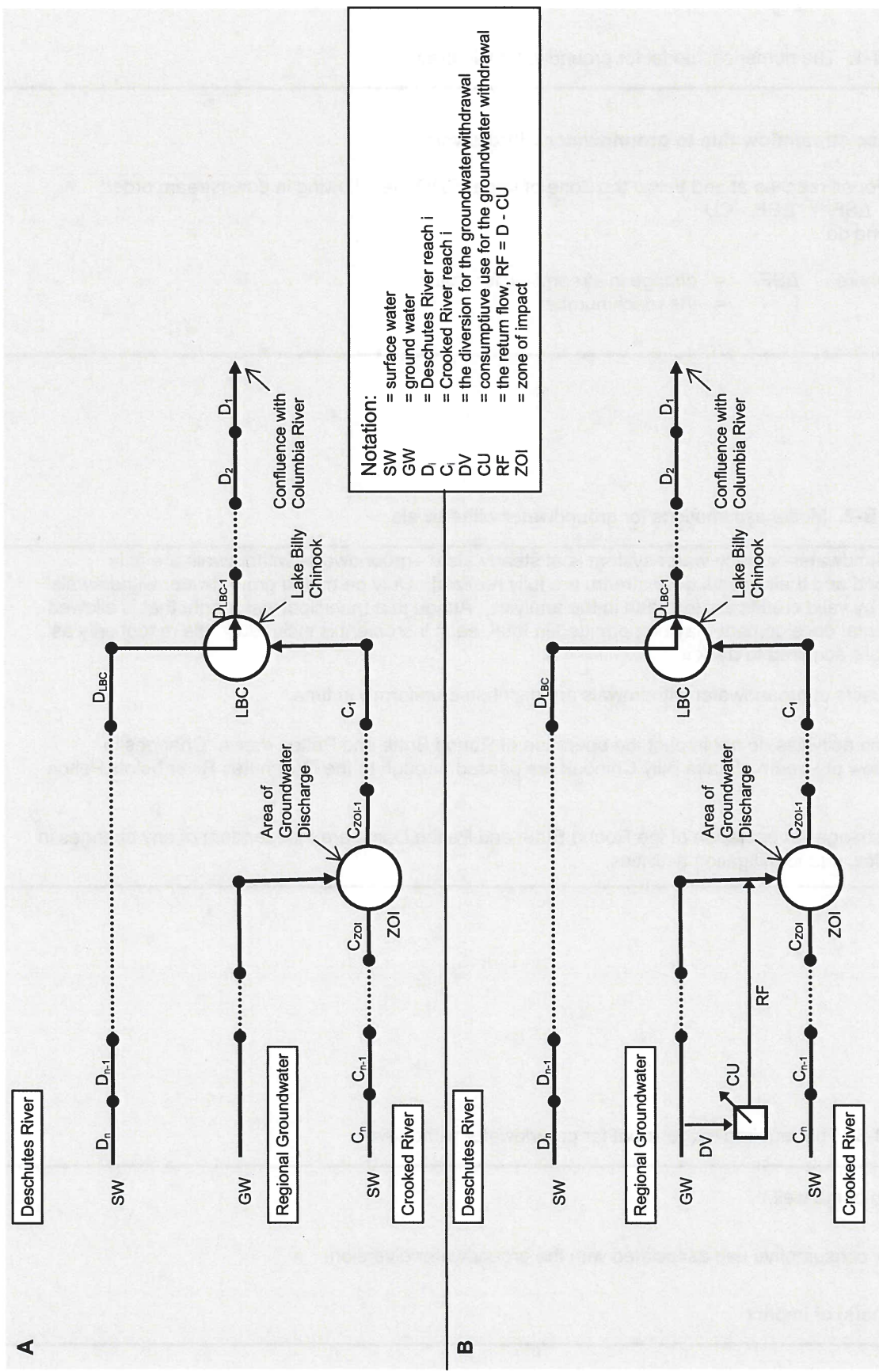
the General Zone (Ken Lite, OWRD hydrogeologist, written communication, 2008).

Table B-4 shows the impact on streamflow from the groundwater withdrawal for four stream reaches: 1) the Deschutes River above the COID diversion, 2) the Deschutes River from the COID diversion to Lake Billy Chinook, 3) the Crooked River from Osborne Canyon to Lake Billy Chinook, and 4) the Deschutes River below Lake Billy Chinook.

The changes in streamflow are shown schematically in Figure B-3.



**Figure B-1.** Where the diversion and the zone of impact are both on the Deschutes River, showing the conceptual models for the cases before (A) and after (B) implementation of a groundwater withdrawal.



**Figure B-2.** Where the diversion is on the Deschutes River and the zone of impact is on the Crooked River, showing the conceptual models for the cases before (A) and after (B) implementation of a groundwater withdrawal.

**Table B-1.** The numerical model for groundwater withdrawals.

---

**Decrease streamflow due to groundwater withdrawals:**

For all reaches at and below the Zone of Impact, DO the following in downstream order:

$$\Delta SF_i = \Delta SF_i - CU$$

end do

where  $\Delta SF_i$  = *change* in streamflow for reach *i*  
*i* = the reach number

---

**Table B-2.** Model assumptions for groundwater withdrawals.

---

The groundwater–surface water system is at steady state - groundwater withdrawals are fully developed and their effects downstream are fully realized. Only permitted groundwater withdrawals backed by valid credits are included in the analysis. Although a municipal water right that is allowed incremental development may be permitted in total, each increment is included in the model only as credits are acquired to back it.

The impacts of groundwater withdrawals are distributed uniformly in time.

Mitigation activities do not impact the operation of Round Butte and Pelton dams. Changes in streamflow upstream of Lake Billy Chinook are passed through to the Deschutes River below Pelton dam.

Future changes in operation of the Round Butte and Pelton Dams are independent of any changes in streamflow due to mitigation activities.

---

**Table B-3.** The required model input for groundwater withdrawals.

---

Location of the well.

CU, the consumptive use associated with the groundwater diversion.

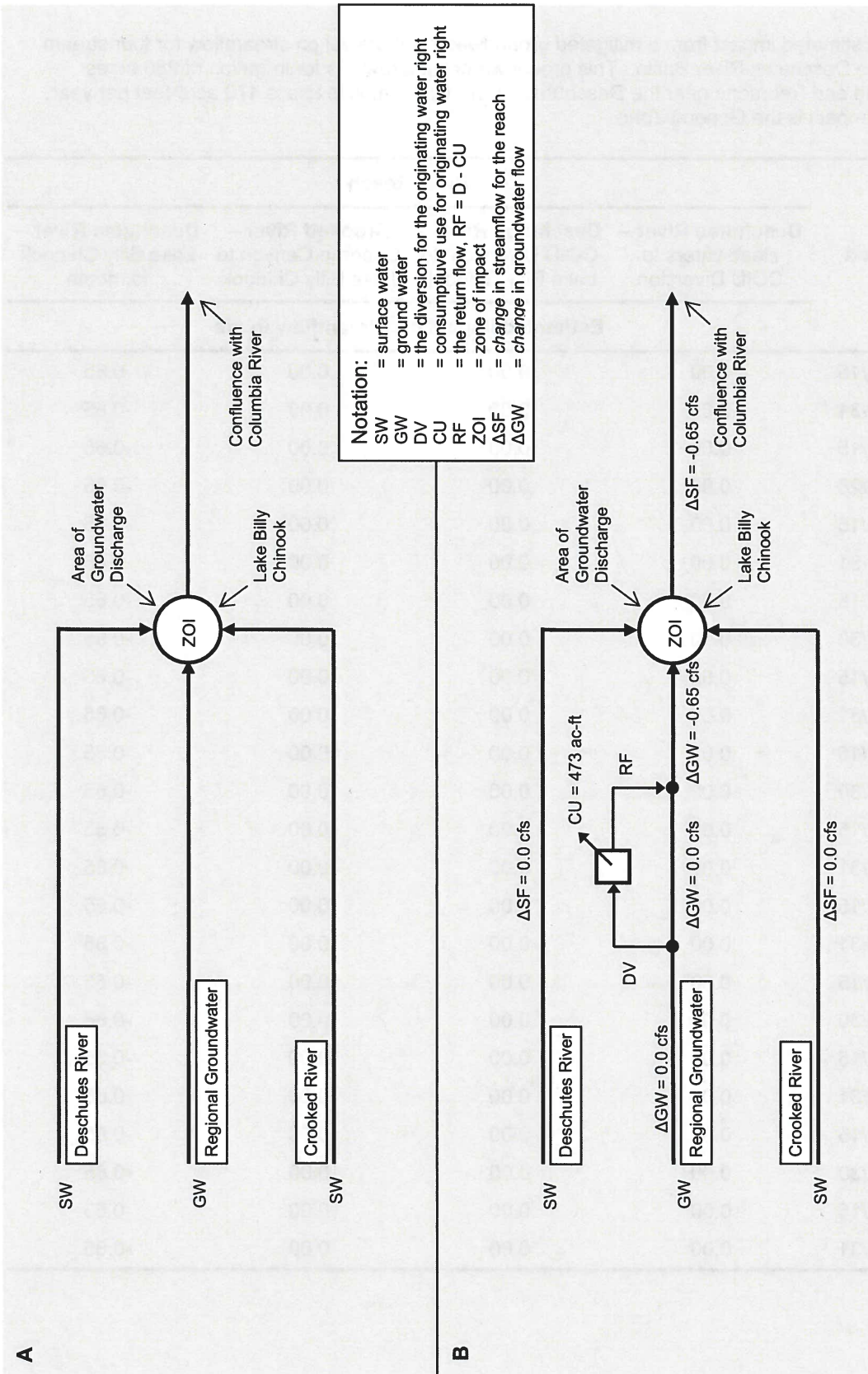
The Zone(s) of Impact

---



**Table B-4.** Estimated impact from a mitigated groundwater withdrawal on streamflow for four stream reaches in the Deschutes River Basin. This groundwater withdrawal is for irrigation of 280 acres between Bend and Redmond near the Deschutes River. Consumptive use is 473 acre-feet per year. The zone of impact is the General Zone.

Time Period	River Reach			
	Deschutes River – Headwaters to COID Diversion	Deschutes River – COID Diversion to Lake Billy Chinook	Crooked River – Osborne Canyon to Lake Billy Chinook	Deschutes River – Lake Billy Chinook to mouth
Estimated Impact on Streamflow in cfs				
01/01 to 01/15	0.00	0.00	0.00	-0.65
01/16 to 01/31	0.00	0.00	0.00	-0.65
02/01 to 02/15	0.00	0.00	0.00	-0.65
02/16 to 02/28	0.00	0.00	0.00	-0.65
03/01 to 03/15	0.00	0.00	0.00	-0.65
03/16 to 03/31	0.00	0.00	0.00	-0.65
04/01 to 04/15	0.00	0.00	0.00	-0.65
04/16 to 04/30	0.00	0.00	0.00	-0.65
05/01 to 05/15	0.00	0.00	0.00	-0.65
05/16 to 05/31	0.00	0.00	0.00	-0.65
06/01 to 06/15	0.00	0.00	0.00	-0.65
06/16 to 06/30	0.00	0.00	0.00	-0.65
07/01 to 07/15	0.00	0.00	0.00	-0.65
07/16 to 07/31	0.00	0.00	0.00	-0.65
08/01 to 08/15	0.00	0.00	0.00	-0.65
08/16 to 08/31	0.00	0.00	0.00	-0.65
09/01 to 09/15	0.00	0.00	0.00	-0.65
09/16 to 09/30	0.00	0.00	0.00	-0.65
10/01 to 10/15	0.00	0.00	0.00	-0.65
10/16 to 10/31	0.00	0.00	0.00	-0.65
11/01 to 11/15	0.00	0.00	0.00	-0.65
11/16 to 11/30	0.00	0.00	0.00	-0.65
12/01 to 12/15	0.00	0.00	0.00	-0.65
12/16 to 12/31	0.00	0.00	0.00	-0.65



**Figure B-3.** A simplified schematic showing the change in streamflow for various reaches of the Deschutes and Crooked Rivers as a result of the groundwater withdrawal given in the example. Case A shows the situation prior to the withdrawal. Case B shows the change in streamflow after the withdrawal is implemented.

# Appendix C - Zone of Impact Determination for a Mitigation Project

By Jonathan L. La Marche

A zone of impact determination is required whenever a mitigation project impacts groundwater. In all cases, the goal is to determine where water that has entered a local or the regional groundwater system, either through direct recharge or by way of return flows from a consumptive use, will be discharged to surface water. The determination is based on the following information:

1. Local shallow and regional groundwater elevations,
2. Shallow and regional groundwater head gradients (i.e., the groundwater flow direction),
3. Surface water elevations of nearby streams,
4. Surface water elevations of the closest gaining stream reaches,
5. Distances to nearby streams and gaining reaches along the local and regional flow paths, and
6. Local geologic information.

The analysis is done using Geographic Information System data taken from groundwater studies of the Deschutes basin (Gannett and others, 2001; Lite and Gannett, 2002; Gannett and Lite, 2004) and the location of the place of use (POU) as specified in the water right application. For many applications, multiple POUs are specified, and an evaluation is done for each. A mitigation project always impacts at least one zone of impact, but may impact multiple zones. Although not used in the mitigation model, the zone of impact affected by transmission losses is also determined as part of this evaluation.

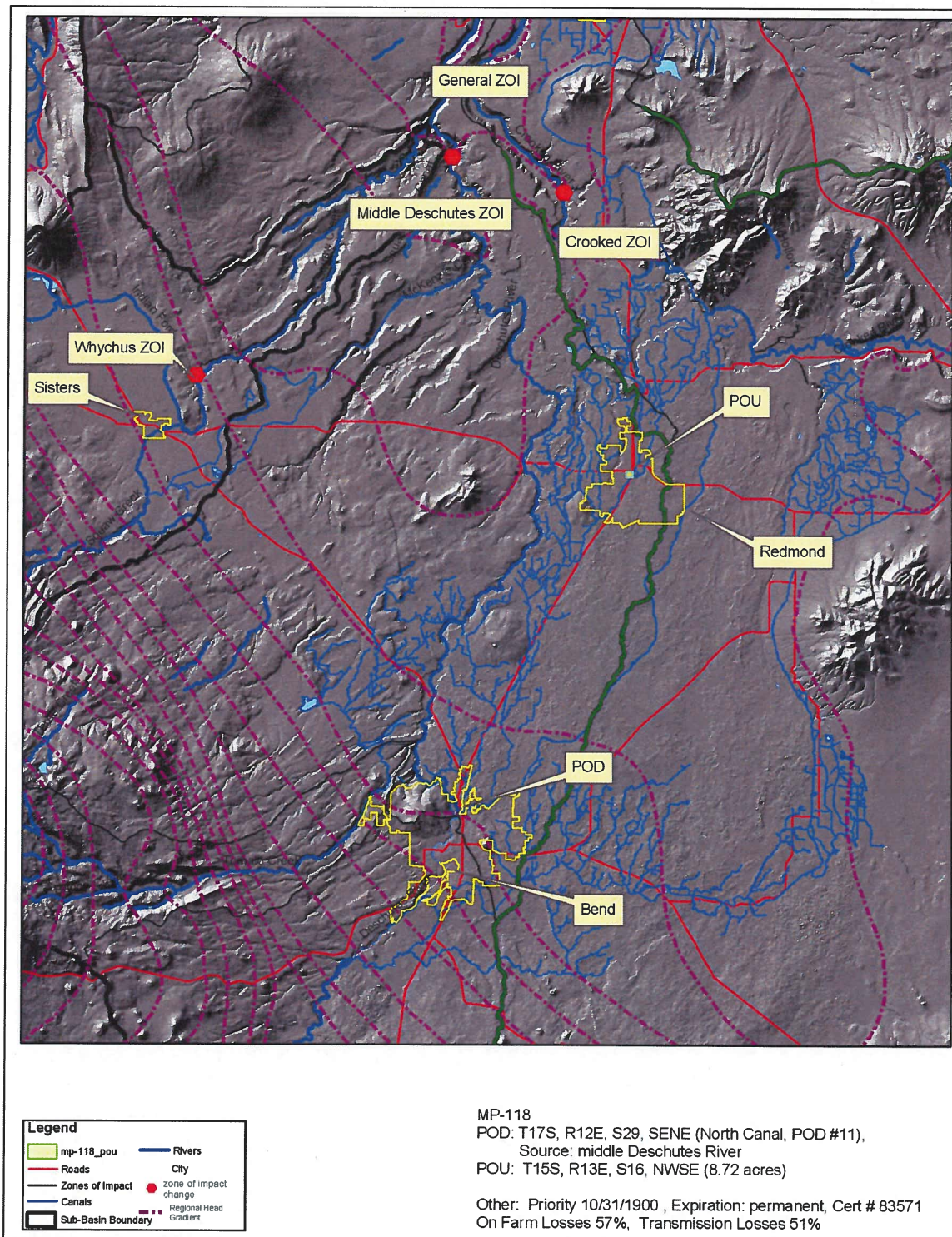
## An Example Evaluation

In this example, a water right is to be leased in-stream to generate mitigation credits. The water right is for irrigation of a parcel of land totaling 8.72 acres (township 15, range 13, and section 16, in the northwest of the southeast quarter-quarter). The irrigation water comes from the North Canal. The required analysis in this case is to determine which zone of impact is affected by return flows from on-farm losses associated with the irrigation.

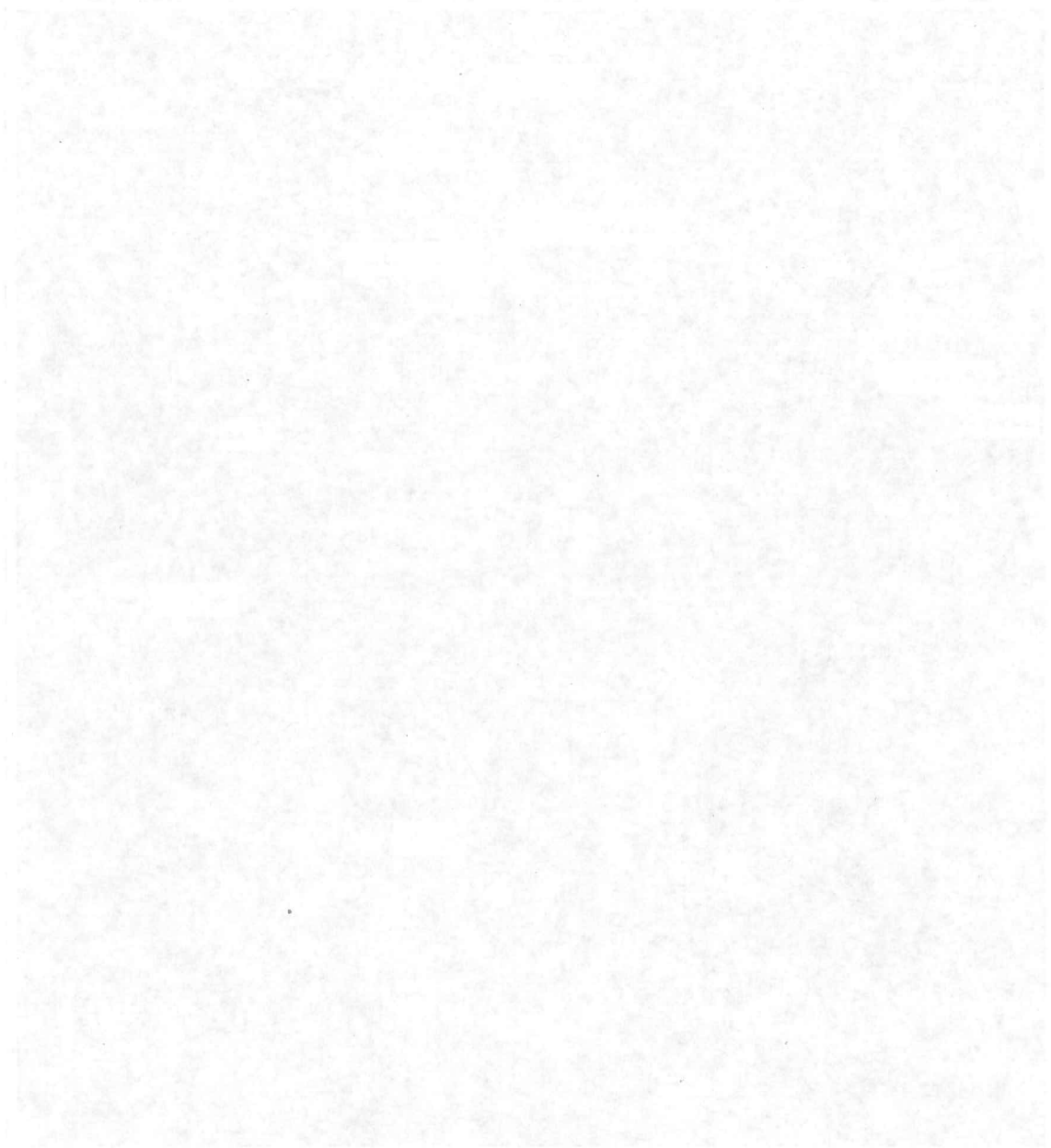
The zone of impact was determined by first plotting the POU on a map of the local area (Figure C-1). Also plotted were the stream network and regional groundwater head gradients (from Gannett et. al. 2001, Lite and Gannett 2004). Relevant data were gathered from this map and other sources and are shown in Table C-1.

The data indicate that return flows most likely infiltrate (local vertical head gradient) and, given the distance between the POU and the nearest gaining reach (>8 miles), have a long flow path with ample opportunity for returns to enter the deeper regional system and discharge in the general zone. The nearby stream network is either above the regional groundwater water level (Cline Falls, < 4miles away) or shows no indication of groundwater inflows (Tethrow Crossing 4.5 miles away).





**Figure C-1.** A map showing the locale near the place of use (POU) for a water right for irrigation that is to be leased in-stream. Shown are the POU, point of diversion (POD), the local zones of impact (ZOI), and contours representing the groundwater head gradient.



The following information is provided for your information. It is not intended to be a substitute for professional advice. Please consult your attorney for more information. This information is provided for your information only. It is not intended to be a substitute for professional advice. Please consult your attorney for more information. This information is provided for your information only. It is not intended to be a substitute for professional advice. Please consult your attorney for more information.

# **Appendix D - Zone of Impact Determination for a Groundwater Withdrawal**

*By* Kenneth E. Lite, Jr.

The hydrologic evaluation to determine which zone of impact is affected by a groundwater withdrawal is made by considering the proposed well's proximity to surface water and to an area of groundwater discharge. Also considered are well construction information, well depth and the portion of the aquifer that the well will produce water from, general ground water flow direction, and other hydrogeologic information. Using this information, it is determined whether the groundwater application must provide mitigation in the general zone of impact or in a local zone of impact.

## **An Example Evaluation**

A well is drilled in Sisters to be used for municipal use. The well is constructed into unconfined water-bearing units within interbedded glacial outwash sediment (silt, sand, and gravel) and Cascade lava flows. The elevation of the hydraulic head (water table surface) in the well is above the elevation of the nearest down-gradient ground-water discharge area in Whychus Creek. The most likely surface water to be impacted by the pumping are tributary springs to Whychus Creek at the eastern base of McKinney Butte. Therefore, the local zone of impact is determined to be Whychus Creek.

