

shall include:

- a. Water quality information for the Low-Temperature Geothermal production well;
- b. Water quality information for ground water in the receiving zone of the reinjection well; and
- c. A description of the proposed installation, including anticipated flow rates and discharge temperatures.

(2) Well Reports indicating water bearing zones and water temperatures for both the production and injection wells must be on file with the Water Resources Department to obtain approval. Water quality information required for approval shall include analysis for the following parameters by a certified laboratory: [Prior to reinjection, users required to file for water rights shall supply the Director fluid quality information concerning the Low-Temperature Geothermal Fluid, the Low-Temperature Geothermal Effluent, and the ground water in the receiving zone of any Low-Temperature Geothermal Reinjection Well for systems that withdraw and reinject ground water in order that the Low-Temperature Geothermal Effluent Disposal System be classified as Standard or Nonstandard. The required information shall include a certified chemical analysis for the following parameters: Temperature,] pH, Suspended Solids, Specific Conductance, Total Dissolved Solids, Total Coliform Bacteria, Arsenic, Boron, Calcium, Carbonate or Bicarbonate, Chloride, Iron, Magnesium, Manganese, Potassium, Silica, Sodium and Sul[f]fate. [If poor water quality or water quality incompatible with the reinjection zone fluids is suspected, the Director may require additional specific data.]

(3) If the Low-Temperature Geothermal Effluent is suspected to be of poor water quality or to be otherwise incompatible with the water in the receiving zone in the reinjection well, the Director may require additional specific water quality data. If the information on the Well Reports for the wells involved is not sufficient to determine the effects of reinjection, the Director may require additional geologic or hydrologic information including but not limited to temperature/ depth logs of the wells. The Director may waive the requirement for specific portions or all of the chemical analysis if the fluid quality is known to be suitable [from] for the intended withdrawal and reinjection.

WATER RIGHTS PROCEDURE

Processing of Applications

690-230-120 The appropriator shall make application for a water right to appropriate Low-Temperature Geothermal Fluid unless an exemption is provided for under ORS 537.545.

Exemption From Water Right Permit Application / Use of Low-Temperature Geothermal Fluid

690-230-130 Low-Temperature Geothermal Fluid appropriation for single industrial or commercial use including, but not limited to, electrical, agricultural, aquacultural, heating and/or cooling in an amount not exceeding 5,000 gallons per day shall be exempt from application for a water right as provided for under ORS 537.545. This exemption applies to the use of ground water for any such purpose to the extent that it is beneficial and constitutes a right to appropriate ground water equal to that established by a ground water right certificate.

Water Right Limitation for Nonstandard Effluent Disposal Systems

690-230-140 If the Low-Temperature Geothermal Effluent is disposed of by way of a Nonstandard Low-Temperature Geothermal Effluent Disposal System, the right to appropriate the Low-Temperature Geothermal Fluid shall be inferior to all subsequent rights for beneficial consumptive use and/or to the rights of those appropriators who make use of a Standard Low-Temperature Geothermal Effluent Disposal System. If a Nonstandard Low-Temperature Geothermal Effluent Disposal System is upgraded to a Standard Low-Temperature Geothermal Effluent Disposal System the associated water right retains the priority date established upon initial filing.

DIVISION 235

GROUND WATER ADVISORY COMMITTEE

Ground Water Advisory Committee: Appointments, Terms, and Qualifications

690-235-005(1) There is created the Ground Water Advisory Committee consisting of five members appointed by the Director: two of whom shall be individuals from the [water] well industry, two of whom shall be ground water geologists or hydrologists, and one of whom shall represent the public-at-large. Members shall be citizens of the United States and residents of Oregon.

(2) Each member shall be appointed for a term of four years from the date of the expiration of the term for which the predecessor was appointed, except when a vacancy occurs before the expiration of a term shall be filled by appointment for the remainder of the unexpired term only.

(3) Members shall be appointed from different geographical

areas, and shall receive neither compensation nor expenses in the performance of their duties as a member.

(4) Officers of Committee: the Committee shall select one of its members as Chairman and another as Vice-chairman. Maximum terms of officers shall be two years for each position.

(5) Meetings of the Committee: the Committee shall meet at least once every three months at locations specified by the Director.

Ground Water Advisory Committee Duties

690-235-020 The Committee shall consider and advise the Director on all matters relating to:

(1) Rules for the development, use, and protection of ground water aquifers.

(2) Rules for examining and issuing of licenses for well constructors.

APPENDIX 1

I. Recommendations For Disinfection of [Water] Wells (OAR 690-210-380)

Every newly constructed, altered, or repaired well should be assumed to be contaminated by micro-organisms. Before the initiation of use, each well must be thoroughly and carefully cleaned and treated to ensure that all disease carrying organisms are eliminated. Care should be exercised to make certain that all areas of the well come into contact with a solution containing enough available chlorine to completely destroy all harmful bacteria. An initial chlorine concentration of 50 parts per million (ppm) with a residual chlorine requirement of 25 ppm after 24 hours is considered adequate for this purpose. Either domestic laundry bleaches containing sodium hypochlorite, such as Clorox or Purex, or calcium hypochlorite in powder or tablet form (Olin HTH) may be used.

Hypochlorite solutions should be thoroughly mixed throughout the well either by the use of drilling tools, a pump, or by placing a calculated number of HTH tablets at regular intervals on a nylon string and dissolving them in places throughout the well. In all cases, the well casing and pump column standing above the water table should be thoroughly cleaned of all grease and oil and should be carefully washed down with the hypochlorite solution.

The well should be allowed to remain undisturbed after the treatment for a period of 24 hours. Then it is recommended that the well be tested for residual chlorine (at least 25 ppm must

remain). After successful treatment, all water remaining in the well and supply system should be run to waste and a sample of fresh water from the well tested by the local county sanitarian for bacteriological purity.

SOLUTIONS CONTAINING HYPOCHLORITES

Laundry Bleach

Common domestic laundry bleaches contain from 5.25 percent to 6.00 percent sodium hypochlorite. These amounts are equivalent to approximately 2.5 percent available chlorine or about 25,000 ppm as originally purchased. A one gallon container of liquid bleach mixed with 500 gallons of water will dilute the original solution to approximately 50 ppm available chlorine.

High-Test Hypochlorite Compounds

Calcium hypochlorite (Olin HTH) in powder or tablet form contains about 50 percent active chlorine. One ounce of dry HTH powder mixed with 75 gallons of water will result in a solution containing approximately 50 ppm available chlorine. Eight tablets (1/8 oz. each) of HTH are equivalent to one ounce of dry powder or granules.

QUANTITY OF HYPOCHLORITE NEEDED TO PROVIDE 50 PPM ACTIVE CHLORINE IN WELL WATER

(1) If using liquid bleaches, the following formula is applicable:

$$\frac{\text{Feet of water in well} \times \text{Gallons per foot}}{62} = \text{Pints of bleach needed}$$

Feet of water = Total depth of well minus static water level multiplied by gallons per foot (See Table II).

(2) If using HTH compounds, the following formula is applicable:

$$\frac{\text{Feet of water} \times \text{Gallons per foot}}{75} = \text{Ounces HTH needed}$$

(3) If HTH tablets are used:

$$\frac{\text{Feet of water} \times \text{Gallons per foot}}{9} = \text{Number of 1/8 oz. tablets needed}$$

**TABLE [I]II
CAPACITY OF DRILLHOLE OR CASING**

Nominal size (inches)	Gallons per linear foot
2	0.163
4	0.653
5	1.020
6	1.469
7	1.999
8	2.611
9	3.305
10	4.080
11	4.937
12	5.875
14	7.997
16	10.445
18	13.219
20	16.320
24	23.501

Additional Requirements by Other State Agencies of Oregon

In the administration of ORS 537.505 to 537.795, the Director of the Water Resources Department has statutory authority under the provisions of ORS 537.780 "to prescribe and enforce general standards for the construction and maintenance of wells and their casings, fittings, valves, and pumps ..." Other agencies of the state have statutory responsibilities that relate either directly or indirectly to the construction and operation of public water supply systems and their source of water supply. These agencies and their responsibilities are listed as follows:

TABLE [II]III

<p>OREGON HEALTH DIVISION 1400 SW 5th Avenue Portland, OR 97201</p>	<p>ORS Chapter 448</p>	<p>Municipal water supply systems. Public water supply systems. Community water supply systems (serving more than three s i n g l e residents)</p>
---	------------------------	--

[OREGON DEPARTMENT OF COMMERCE] ORS Chapter 446
Labor and Industries Building]
BUILDING CODES AGENCY
403 L & I Bldg.
Salem, Oregon 97310

Electrical
and Plumbing
for all
Commercial
Enterprises
Mobile home
park water
supply systems.

OREGON PUBLIC UTILITY
COMMISSIONER
Labor and Industries Building
Salem, OR 97310

ORS Chapter 757

Private owners
(water supply
systems, 200
homes or more).

DEPARTMENT OF ENVIRONMENTAL
QUALITY
[SW 5th]811 SW 6th
Portland, OR [97201]97204

ORS Chapter 468

Water quality
monitoring 522
wells.

CORPORATION DIVISION
Business Registry Section
Commerce Bldg.
158 12th St. NE
Salem, Or. 97310

Business
Registry for
Water Districts

All wells constructed in Oregon, including those to serve as a source of ground water to municipal, community, public, or public utility water supply systems, must be constructed in accordance with the rules and regulations prescribing general standards for the construction and maintenance of wells in Oregon (OAR 690 Divisions 205, 210, 215 and 220. Additional construction standards for water supply systems are required by the above listed agencies. Such rules and regulations generally include the source of water supply to the systems and may affect well construction requirements. Copies of the various agency rules may be obtained by contacting the responsible agency. Well [contractors] constructors planning to construct a well as a source of water supply for any of the above systems are requested to contact the responsible agency prior to the beginning of well construction.

APPENDIX 2

I. Recommended Methods of Placement of Cement Grout (OAR 690-210-320)

Method A - The well bore shall be plugged with a drillable plug or bridge at the lowest point to be sealed. A well casing with a float shoe at its lower end shall be placed in the well and suspended slightly above the point of bearing. A grout pipe shall be run inside the casing to the check valve. The grout pipe shall be connected to a suitable pump and water or drilling fluid shall first be circulated to clear the annular space. Grout shall be pumped through the grout pipe until clean grout completely fills the interval to be sealed. The grout pipe shall then be removed and the cement allowed to set. (See Figure 2.)

Method B - Grout shall be placed by pumping or air pressure injection through a grout pipe installed inside the casing from the casing head to a point five (5) feet above the bottom of the casing. The grout pipe shall extend through an airtight sealed cap on the head of the well casing. The casing head shall be equipped with a relief valve and the grout pipe shall be equipped at the top with a valve permitting injection. The lower end of the grout pipe and the casing shall be open. Clean water shall be injected down the grout pipe until it returns through the casing head's relief valve. The relief valve is then closed and injection of water is continued to clean the hole until it flows from the bore hole outside the casing that is to be grouted in place. Without significant interruption, grout shall be substituted for water and, in a continuous manner, injected down the grout pipe until it returns to the surface outside of the casing. A small amount of water may be used to flush the grout pipe, but the pressure should remain constant on the inside of the grout pipe and the inside of the casing until the grout has set. Pressure shall be maintained for at least twenty-four (24) hours, or until such time as a sample of the grout indicates a satisfactory set. Cement grout shall be used for this procedure with a minimum annular space of one (1) inch completely surrounding the casing. (See Figure 2).

Method C - The well bore shall be plugged with a drillable packer or bridge at the lowest point to be sealed. The well casing shall be firmly seated at the bottom of the drillhole. A grout pipe shall be run to the bottom of the hole through the annular space between the casing and the well bore. After water or any other drilling fluid has been circulated in the annular space sufficiently to clear obstructions, the grout pipe shall be connected to a suitable pump and grout shall be pumped through the grout pipe until clean grout is circulated to land surface, or until grout completely fills the interval to be sealed. The lower end of the grout pipe shall remain submerged in grout at all times during the period that grout is being placed. The grout pipe shall be withdrawn before the initial set of the grout. (See Figure 2.)

Method D - The well bore shall be plugged with a drillable packer or bridge at the lowest point to be sealed. After the

casing is run and landed, a casing plug, having a length greater than the diameter of the casing, shall be placed in the casing. If the drillhole is free of mud or water, this lower separation plug may be eliminated. A measured amount of cement grout necessary to completely fill the annular space of the interval to be grouted is pumped or placed by bailer in the casing. A second casing plug, having a length greater than the diameter of the casing, shall be placed in the casing above the grout, and the casing shall be capped with a pressure cap and shut-off valve, and shall be connected to a suitable pump. The casing shall then be raised far enough above the point of bearing to clear the first separation plug. Water or drilling mud shall then be pumped under pressure into the casing forcing the grout and upper casing plug down the casing. The position of the plug must be known at all times. A small amount of the grout shall be allowed to remain in the lower end of the casing. When the plug reaches the point desired above the bottom of the casing, the pump shall be stopped and the casing seated. (See Figure 2.)

Method E - The well bore shall be plugged with a drillable packer or bridge at the lowest point to be sealed. A sufficient amount of cement grout to completely fill the interval of the well to be sealed shall be placed at the bottom of the drillhole by dump bailer, grout pipe, or tremie pipe. The well casing shall have centering guides attached at appropriate intervals to keep the casing center in the bore hole. The bottom of the well casing shall be fitted with a tight drillable plug and shall be lowered into the drillhole forcing the grout upward into the annular space. Gravity installation without the aid of a tremie or grout pipe shall not be used. In no instance shall this method be used beyond a depth of thirty (30) feet and in no case for a municipal, community, or public water supply well. (See Figure 2.)

TABLE (III) IV
(690-210-190)
 (Minimum specifications for steel well casing)

Nomi[m]nal Size (inches)	Outside Diameter (inches)	Wall Thickness (inches)	Weight Per Foot (pounds)
2	2.375	.154	3.56
2-1/2	2.875	.203	5.79
3	3.500	.216	7.58
3-1/2	4.000	.226	9.11
4	4.500	.237	10.79
5	5.563	.244	13.70
6	6.625	.250	17.02

8	8.625	.250	22.36
10	10.750	.250	28.04
* 12	12.750	.312	41.45
* 14	14.000	.312	45.68
* 16	16.000	.312	52.27
* 18	18.000	.375	70.59
* 20	20.000	.375	78.60

Note: Steel casing installed in a well greater than a nominal diameter of ten (10) inches, having a wall thickness of .250 inch and meeting ASTM A-120 specifications must not exceed the following depth limitations (Diameter-Maximum Depth, respectively):

- (a) 12 inches - 250 feet;
- (b) 14-16 inches - 150 feet;
- (c) 18-20 inches - 100 feet;

TABLE [I]V
(690-210-220)
(Set time for plastic casing joints)

Temperature Range During Initial Set Time	Set Time for Various Pipe Sizes In Hours					
	3"	4"	6"	8"	10"	12"
60 F - 100 F	1/2	1/2	1/2	3/4	3/4	1
40 F - 60 F	2	2	4	4	4	4
0 F - 40 F	6	6	8	10	12	12

NOTE: After the initial set, the joints will withstand the stress of a normal installation. However, considerable care should be employed in handling the string.

TABLE VI
(690-210-180)
(Specifications for Drive Pipe)

Nominal Size (inches)	Outside Diameter (inches)	Wall Thickness (inches)	Weight Per Foot (pounds)
1-1/2	1.900	0.145	2.72
2	2.375	0.154	3.65
2-1/2	2.875	0.203	5.79
3	3.500	0.216	7.58
3-1/2	4.000	0.226	9.11

RECOMMENDED USE OF CENTERING GUIDES

(690-210-240)

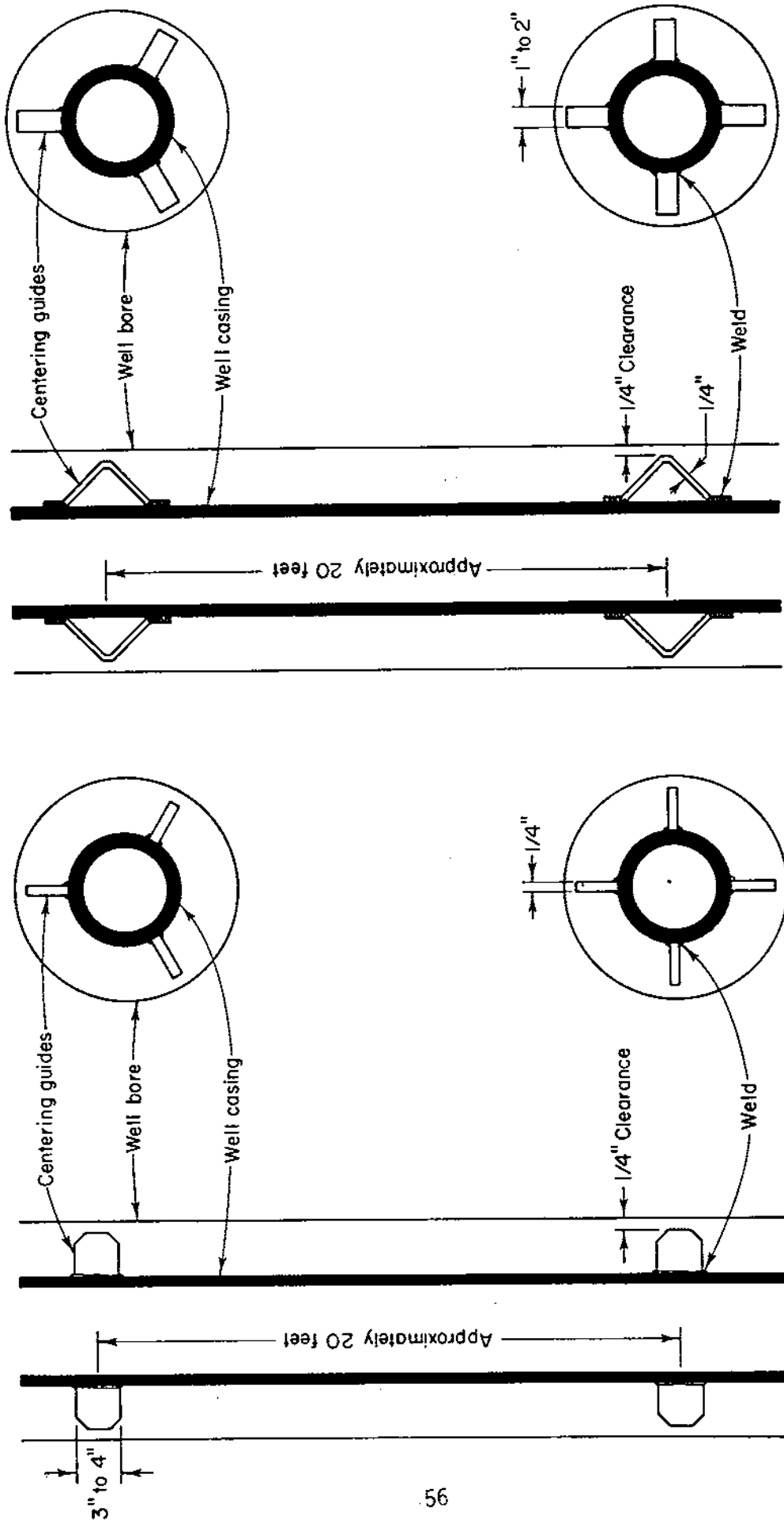

NOTE: Well casing, to be sealed into an oversize drillhole, should be equipped with a series of centering guides to insure proper centering of casing. Guides should be evenly spaced in groups of 3 or 4, and attached to the casing.

FIGURE 1

01000 8

CEMENT GROUT PLACEMENT
(690-21 20)

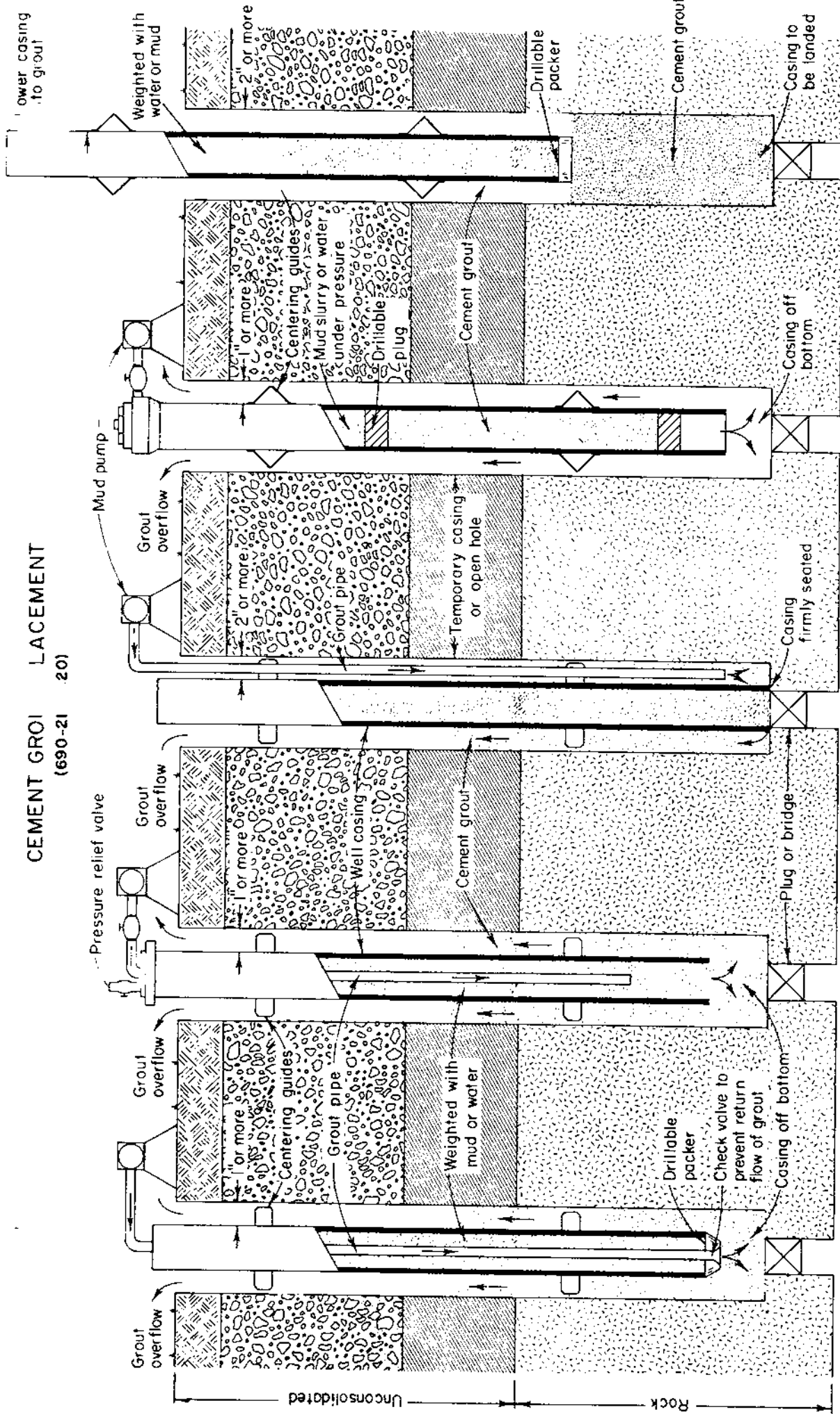

METHOD A

METHOD B

METHOD C

METHOD D

METHOD E

Note: If Method E is used to place the seal, centering guides must be attached to the casing.

FIGURE 2

OWRO'66

SEALING OF DRILLED WELL IN UNCONSOLIDATED FORMATION WITHOUT SIGNIFICANT CLAY BEDS

(690-210-130)

Overlying Material - Sand and Gravel without Clay

Water-bearing Formation - Sand and Gravel or Similar

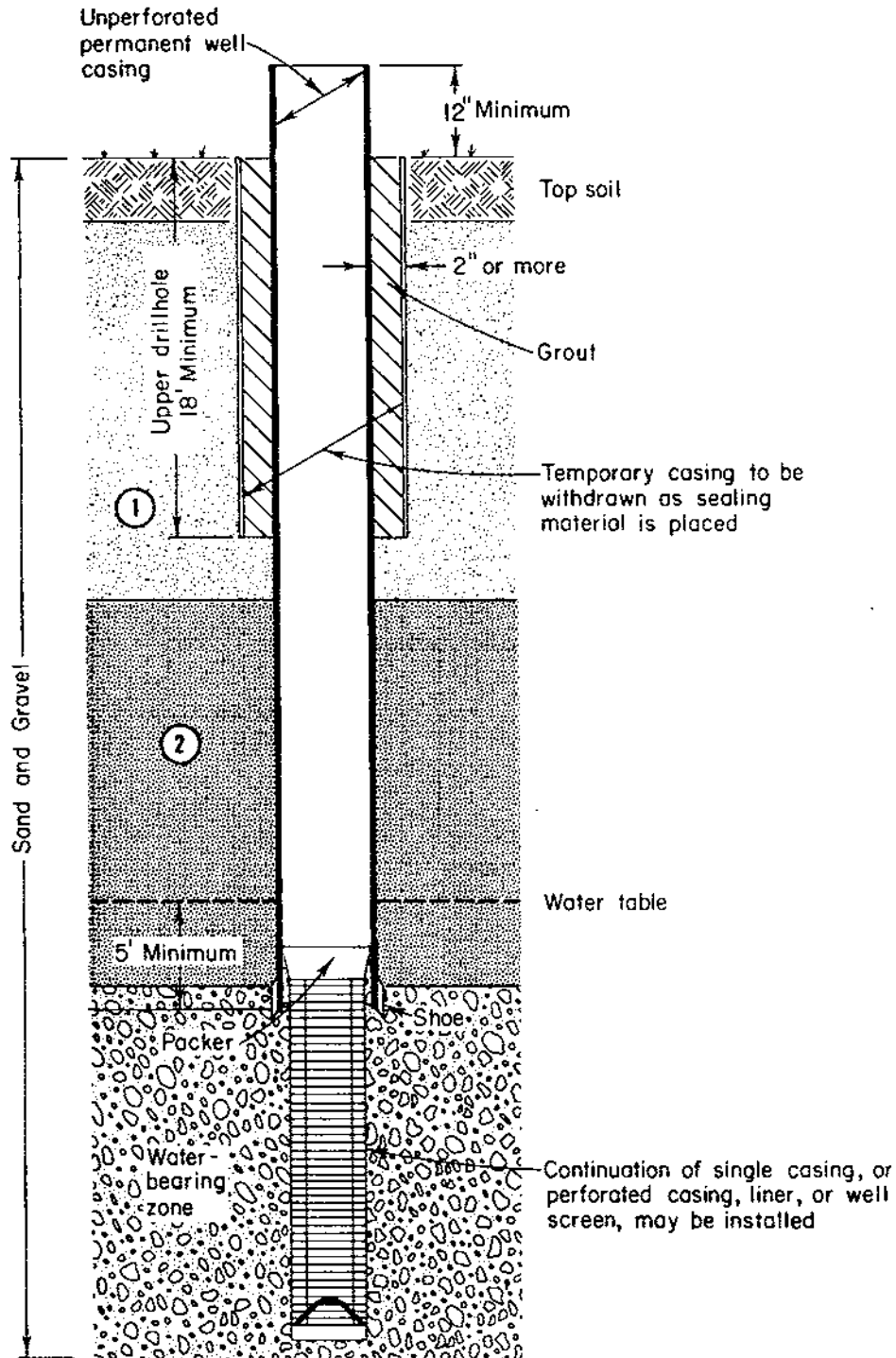

- ① Upper oversize drillhole and annular seal must extend to a depth of at least 18 feet.
- ② Unperforated watertight well casing must extend at least 5 feet below the water table and to a minimum depth of 18 feet.

SEALING OF DRILLED WELL IN UNCONSOLIDATED FORMATION WITH SIGNIFICANT CLAY BEDS

(690-210-140)

Overlying Material - Clay, or Sand and Gravel with Interbedded Clay
 Water-bearing Formation - Any Material Except Rock

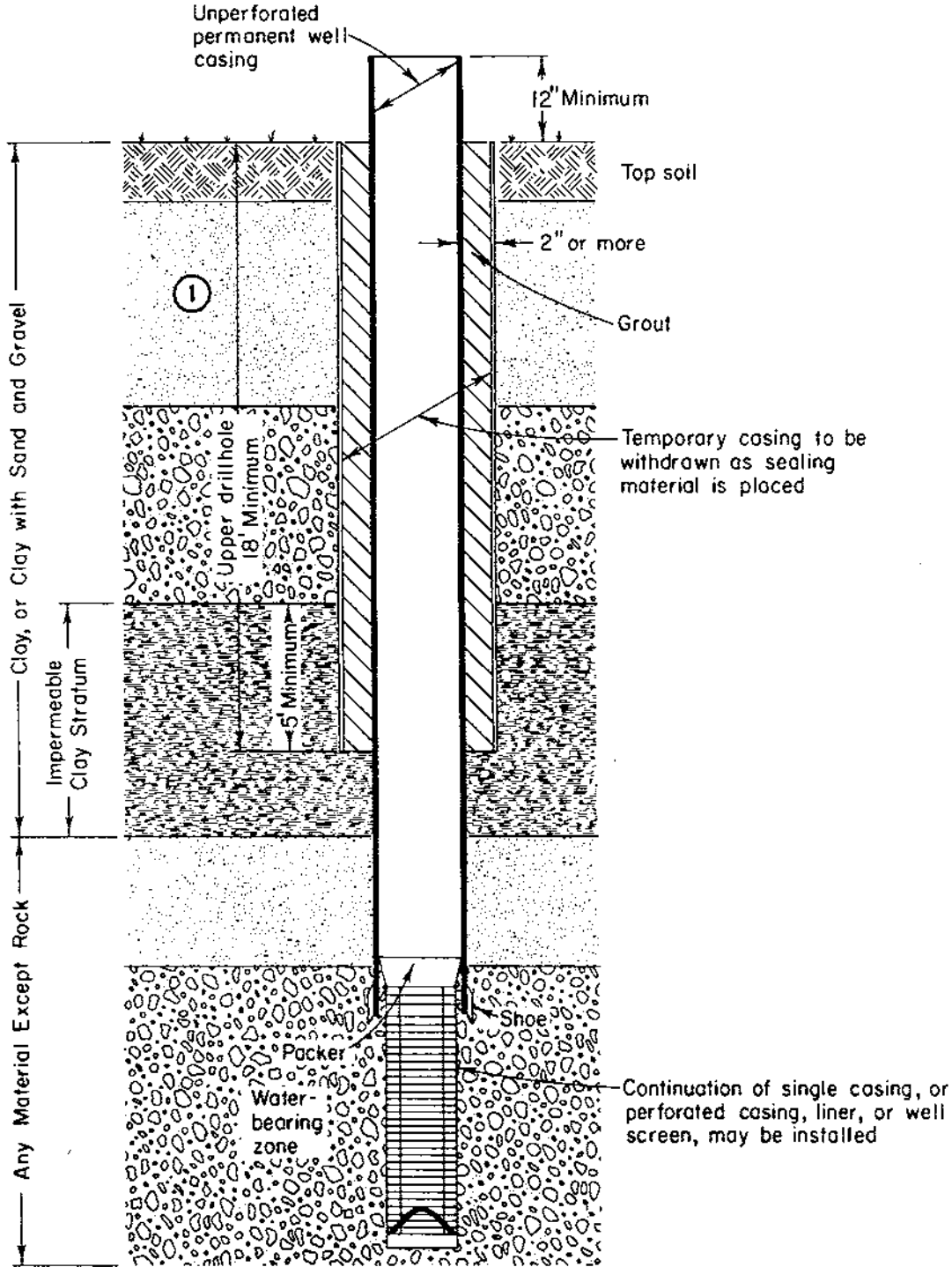

① Unperforated well casing and annular seal must extend at least 5 feet into impermeable stratum, and must extend at least 18 feet below land surface.

FIGURE 4

SEALING OF A DRILLED WELL IN CONSOLIDATED FORMATION

(690-210-150)

Overlying Material - Clay, Sand, or Gravel

Water-bearing Formation - Rock

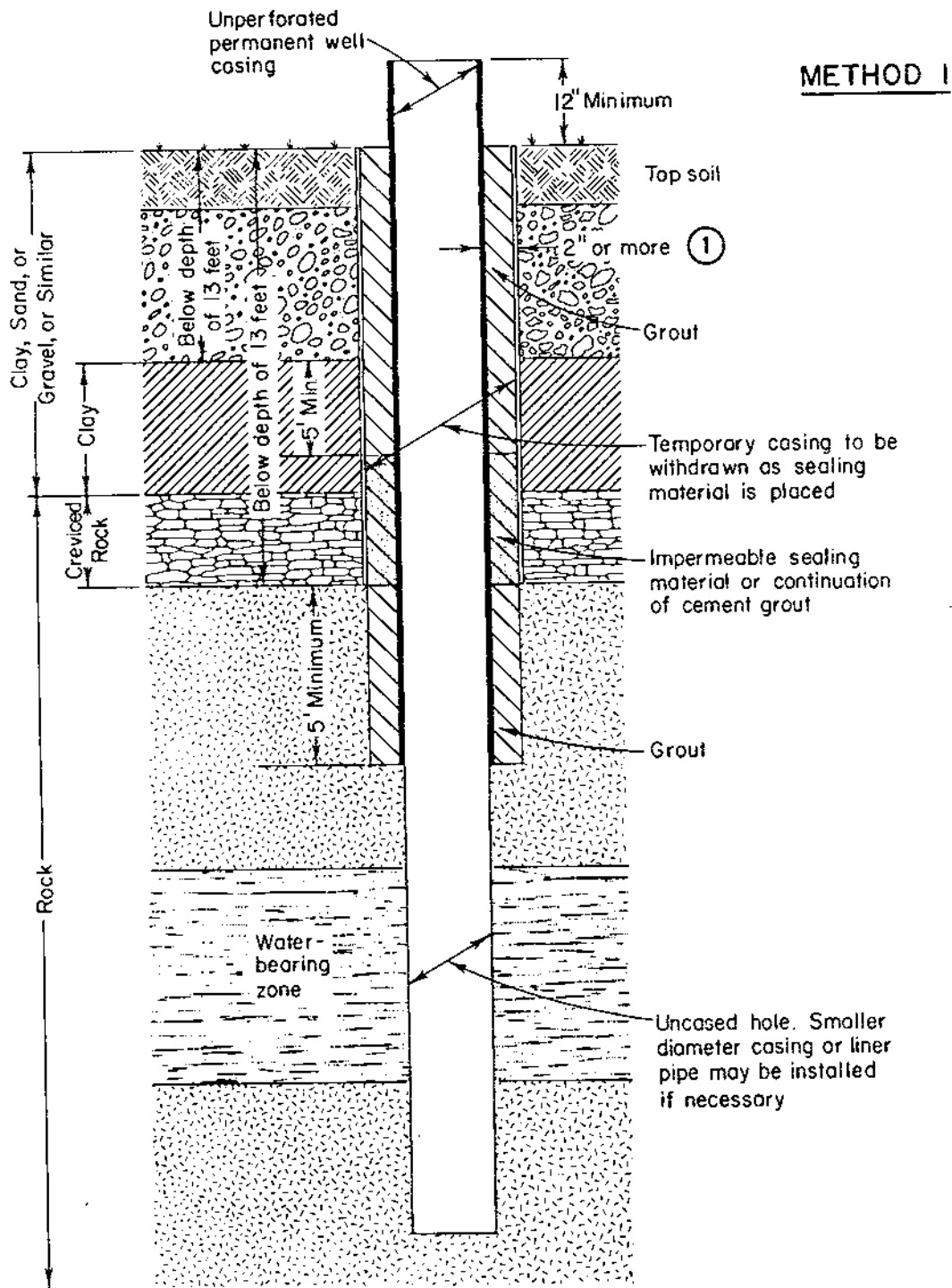

① 1" or more if cement grout is placed by grouting method A, B, or D.

SEALING OF A DRILLED WELL IN CONSOLIDATED FORMATION

(690-210-150)

Overlying Material - Clay, Sand, or Gravel, or Similar

Water-bearing Formation - Rock

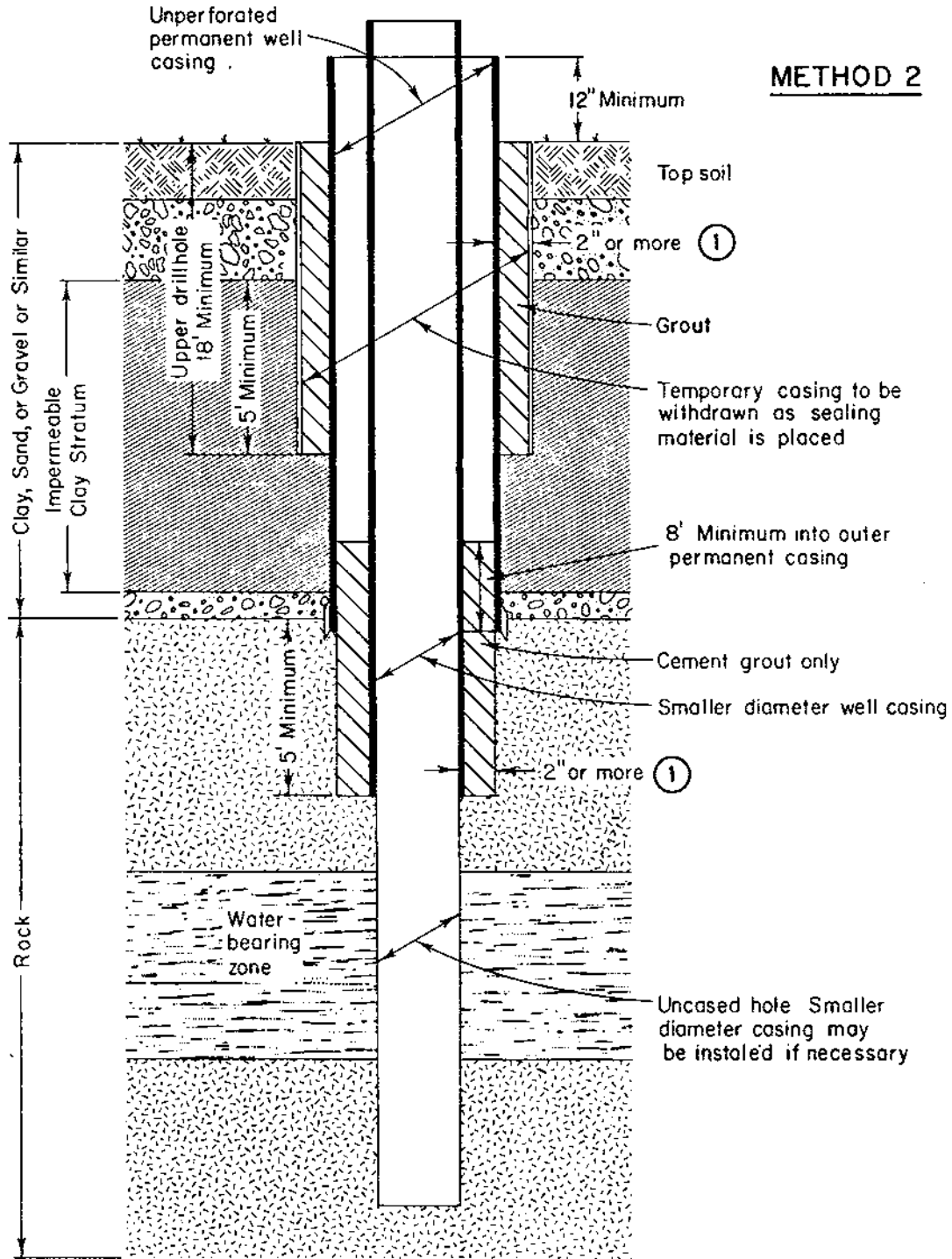

METHOD 2

① 1" or more if cement grout is placed by grouting method A, B, or D.

SEALING OF A DRILLED WELL IN CONSOLIDATED FORMATION

(690-210-150)

Overlying Material - Clay, Sand, or Gravel or Similar

Water-bearing Formation - Rock

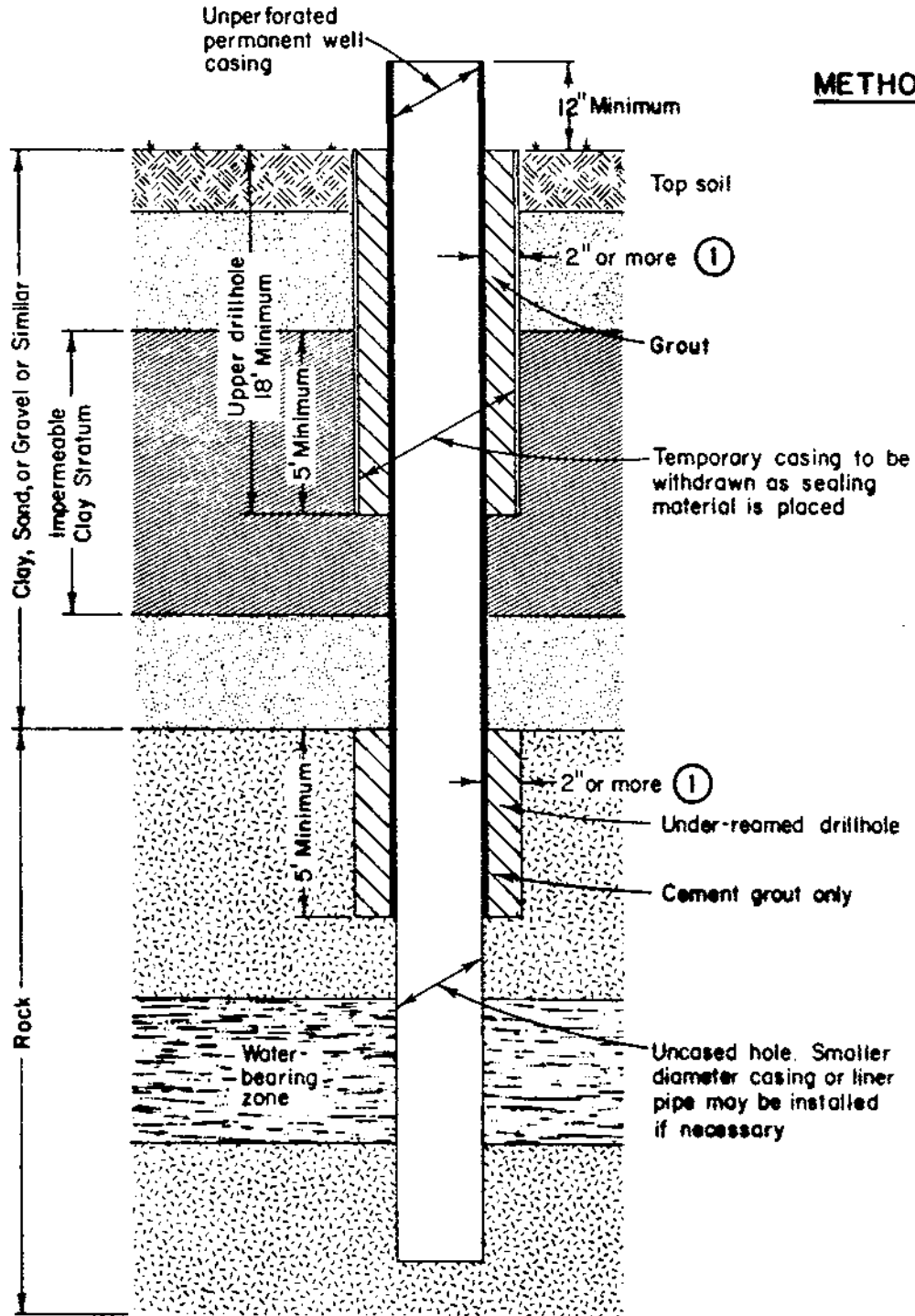

① 1" or more if cement grout is placed by grouting method A, B, or D.

SEALING OF A FILTER PACKED WELL WITH SURFACE CASING

(690-210-150)

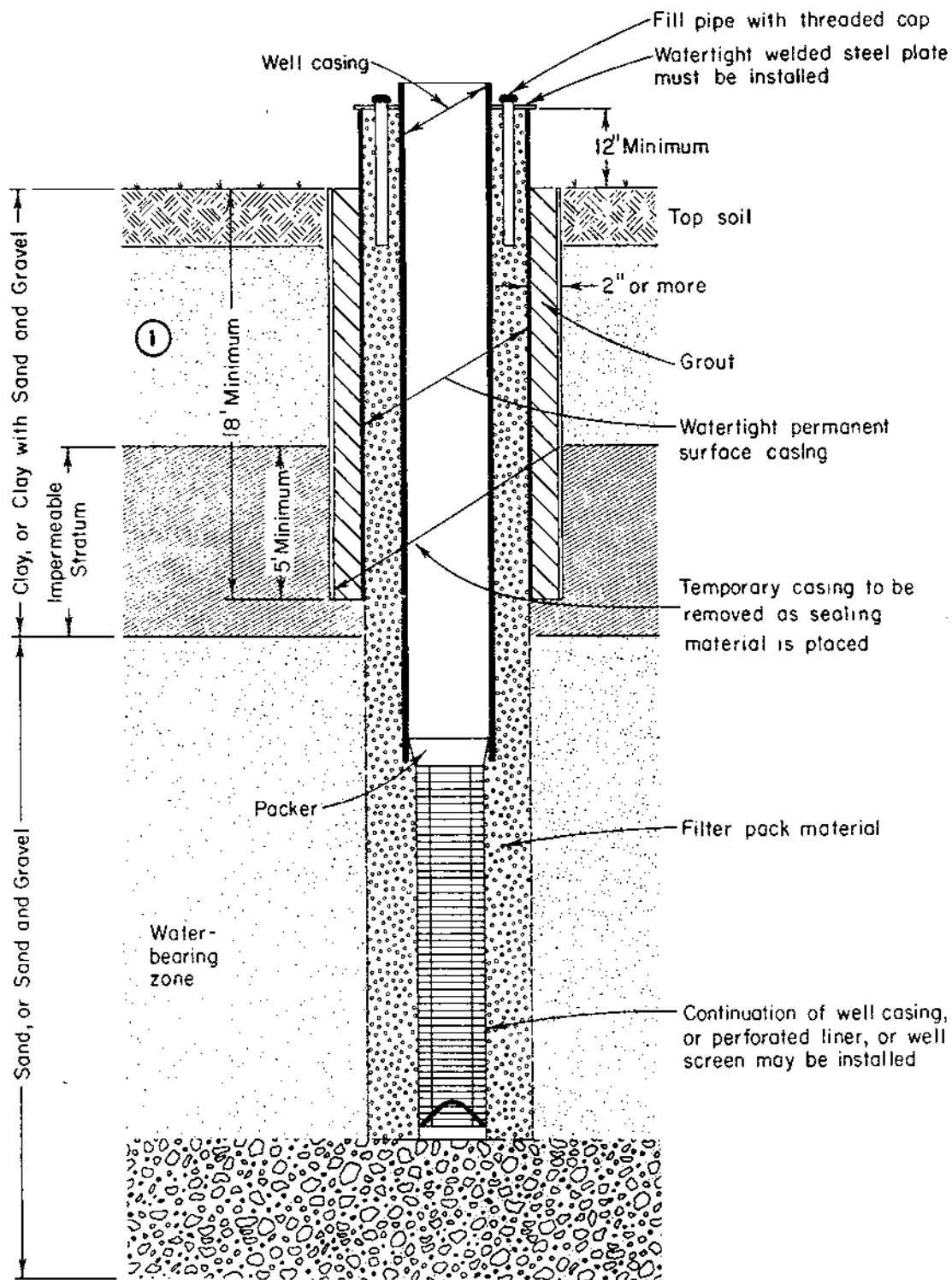

① Minimum of 18 feet provided that the impermeable stratum is at or near land surface.

SEALING OF A FILTER-PACKED WELL WITHOUT SURFACE CASING

(690-210-170)

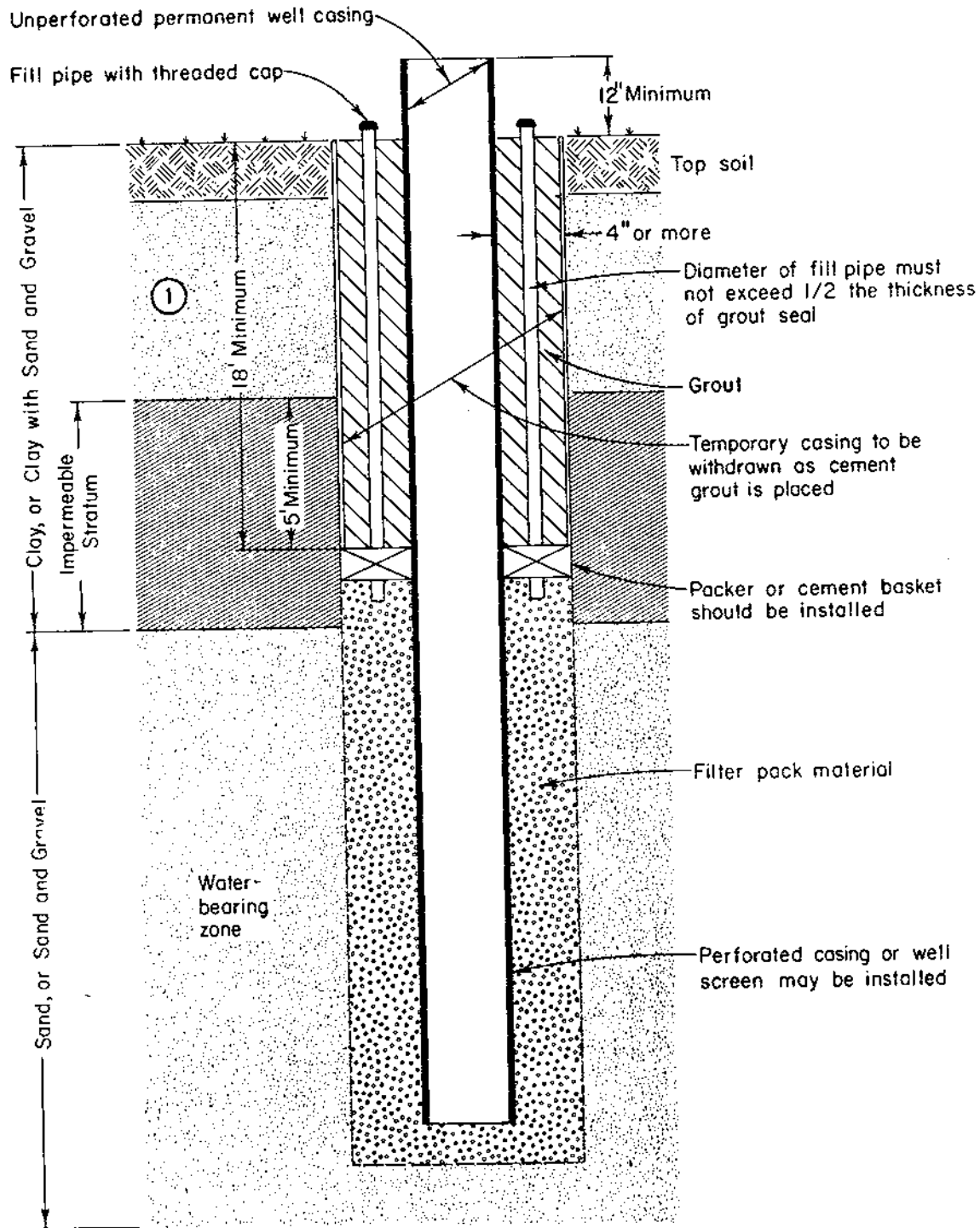

① Minimum of 18 feet provided that the impermeable stratum is at or near land surface.

SEALING OF AN ARTESIAN WELL

(690-210-120)

NOTE:
Petcock and gage may be placed at any of these locations

Control valve and pressure gage must be installed on flowing wells

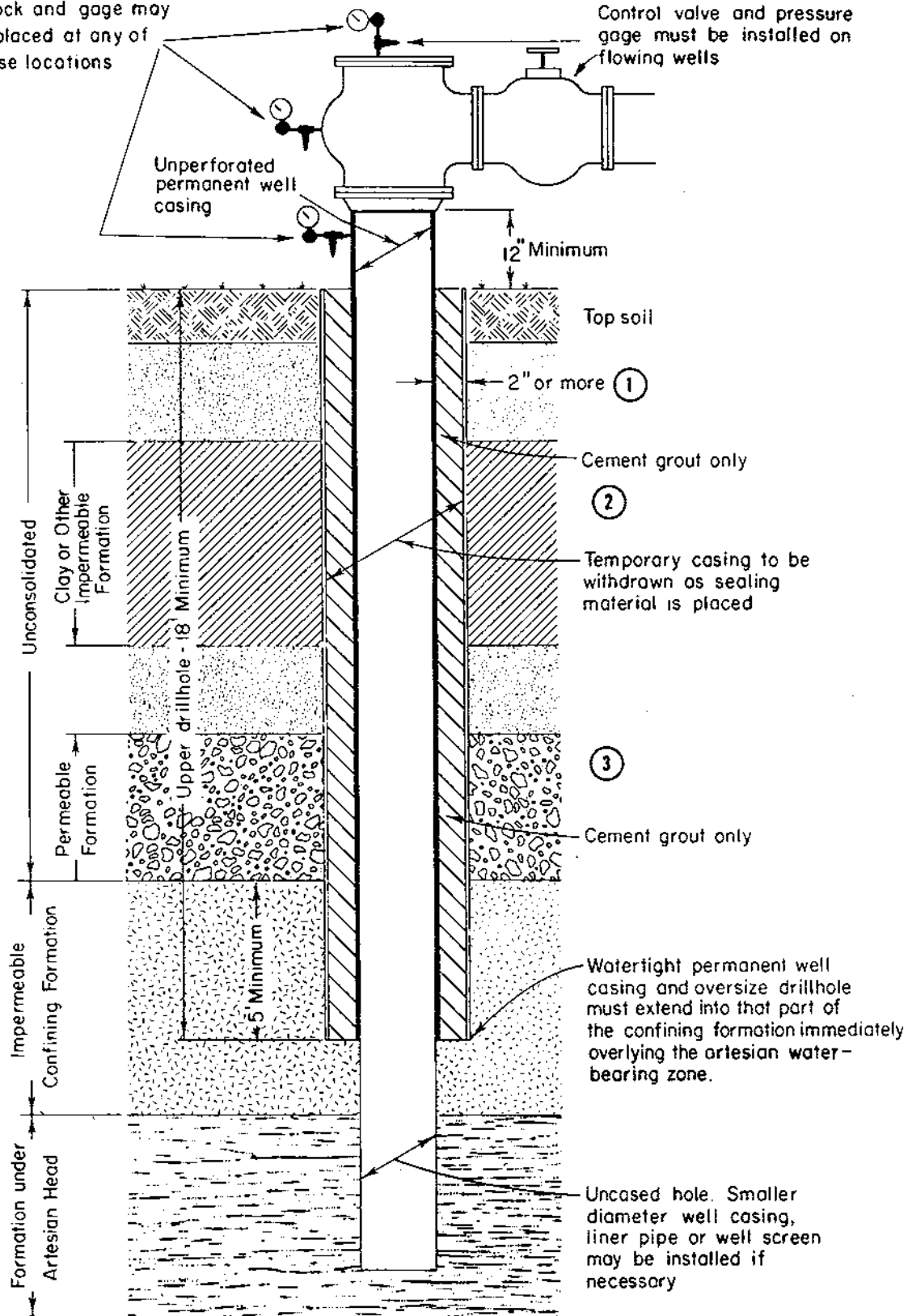

- ① 1" or more if cement grout is placed by grouting method A, B, or D.
- ② Well must not be constructed in a manner that will allow water from an artesian zone to commingle with other confined or unconfined water-bearing zones
- ③ Must be completed with the seals, packers, or casing necessary to eliminate subsurface or surface leakage.

SEALING OF A DRIVEN OR JETTED WELL

(690-210-180)

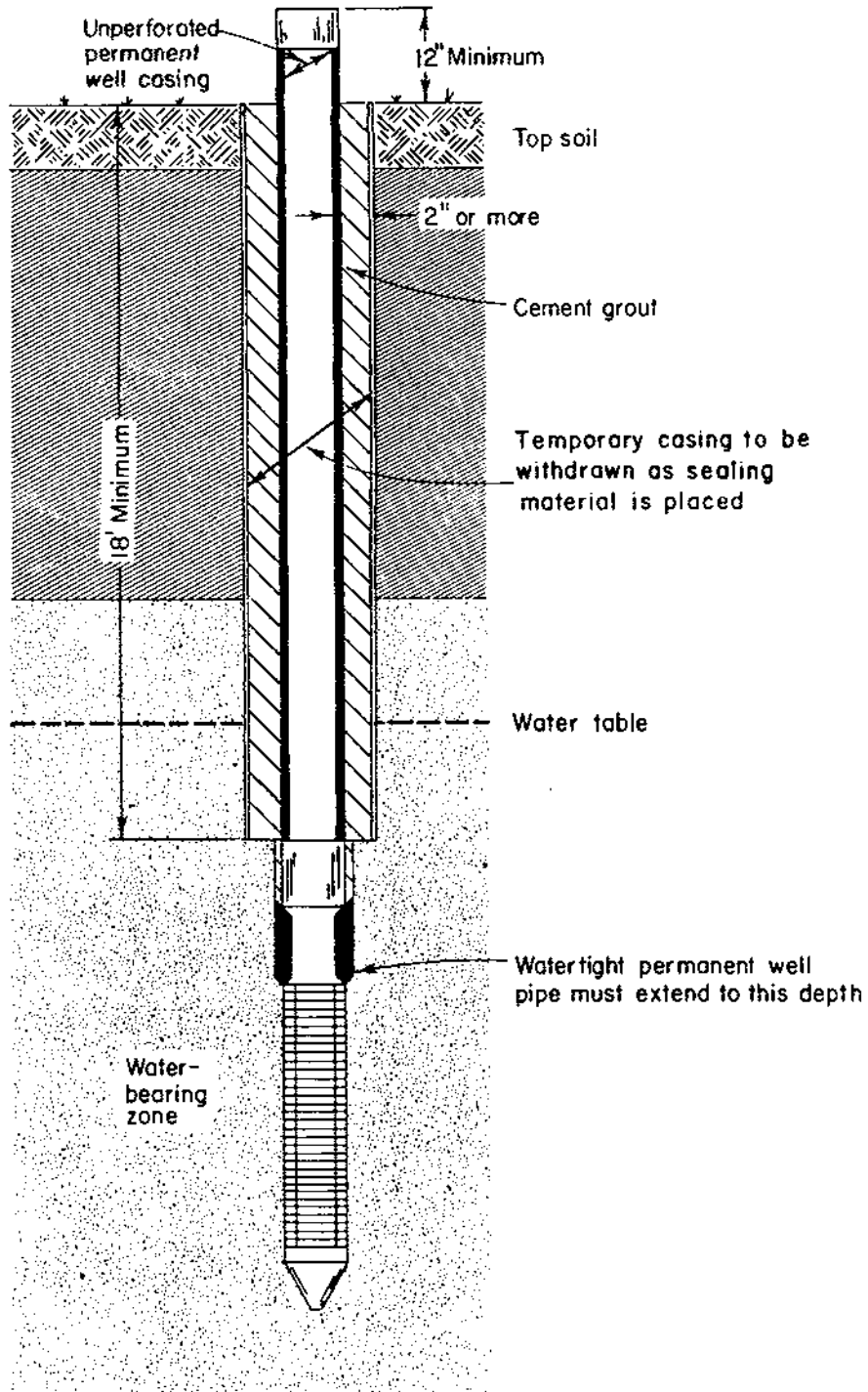

FIGURE 11

SEALING OF DUG WELLS
(690-210-410) (690-210-420)

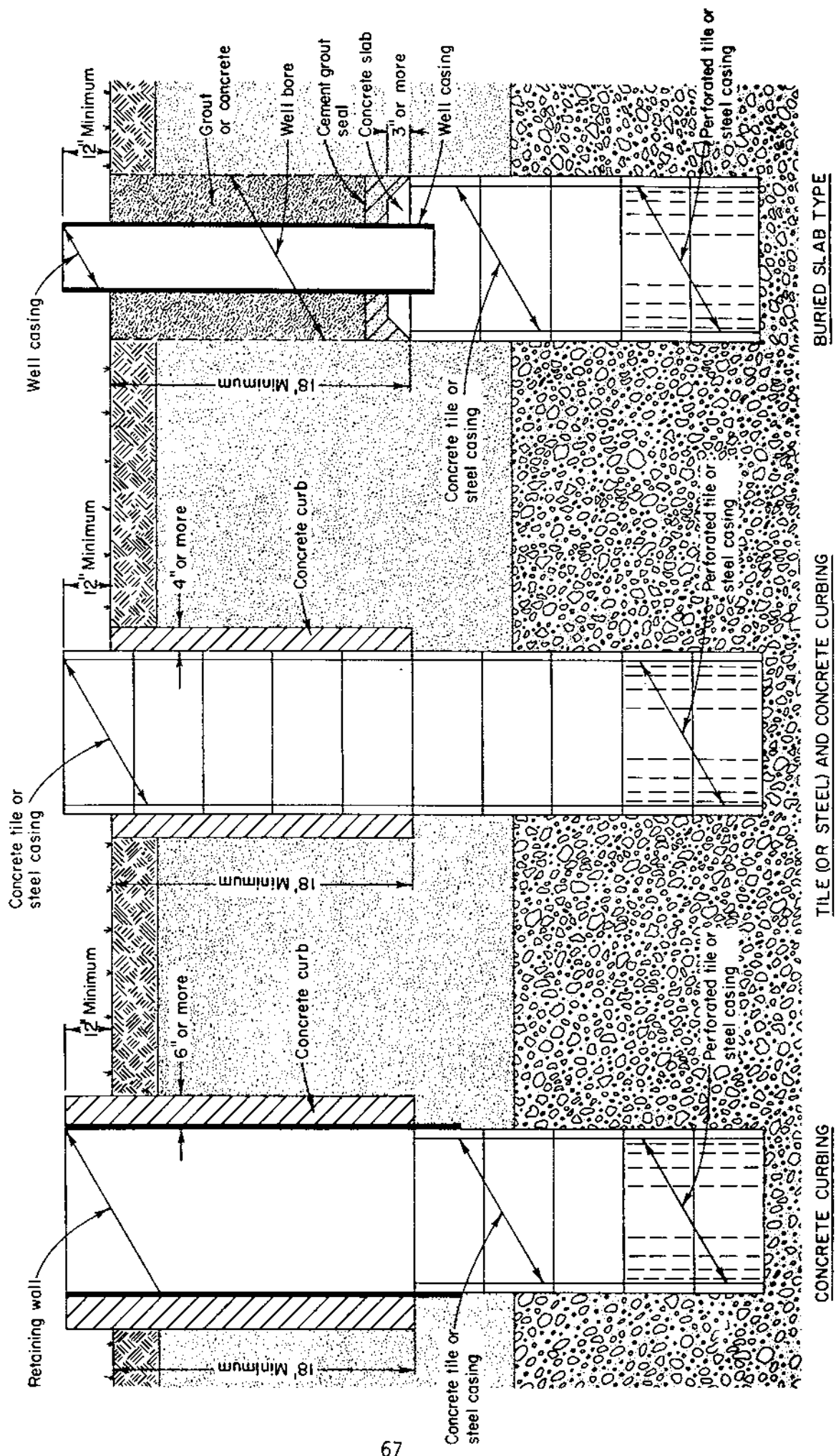

FIGURE 12

BURIED SLAB TYPE

TILE (OR STEEL) AND CONCRETE CURBING

CONCRETE CURBING

ABANDONMENT OF UNCASED WELL IN UNCONSOLIDATED FORMATION

(690-220-040)

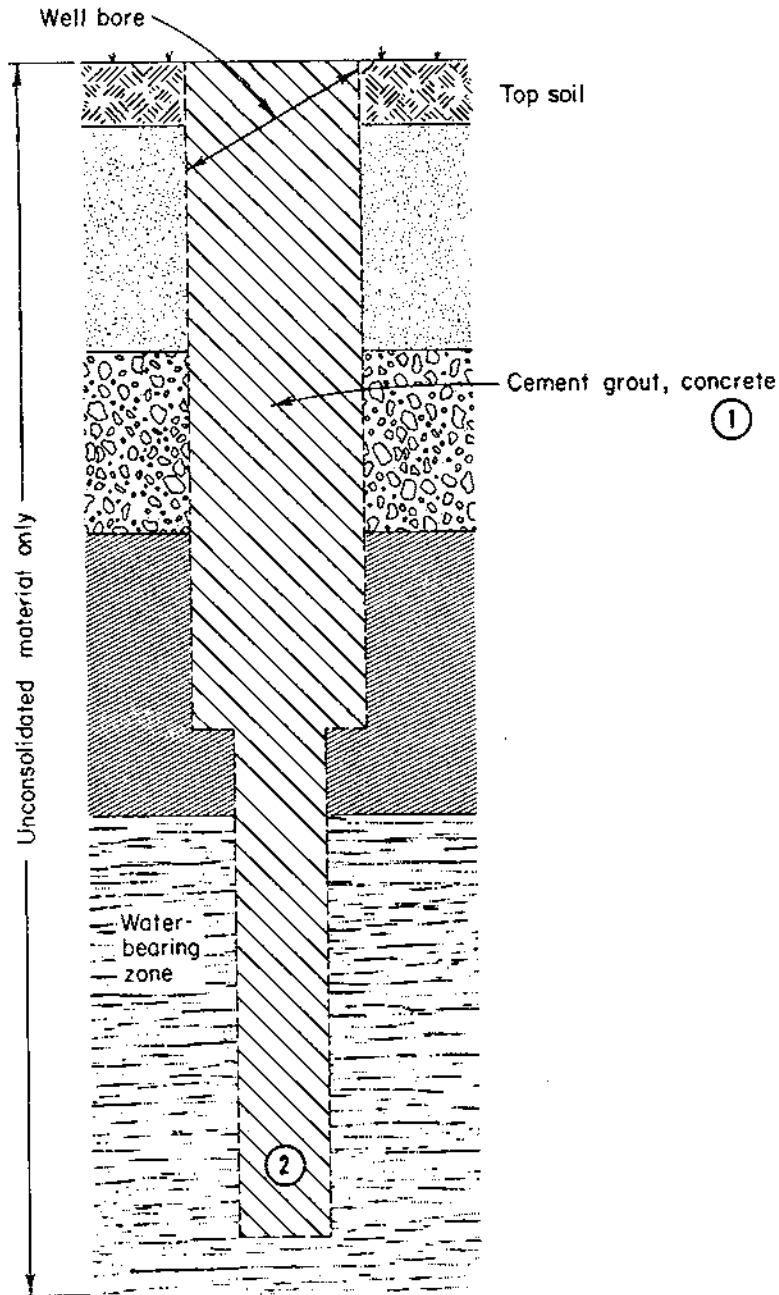

- ① In all wells to be abandoned, cement grout and concrete must be placed by grout pipe, tremie, or dump bailer.
- ② In all wells to be abandoned, sealing material must be introduced at the bottom of the well and placed progressively upward.

FIGURE 13

ABANDONMENT OF UNCASED WELL IN CONSOLIDATED FORMATION

(690-220-050)

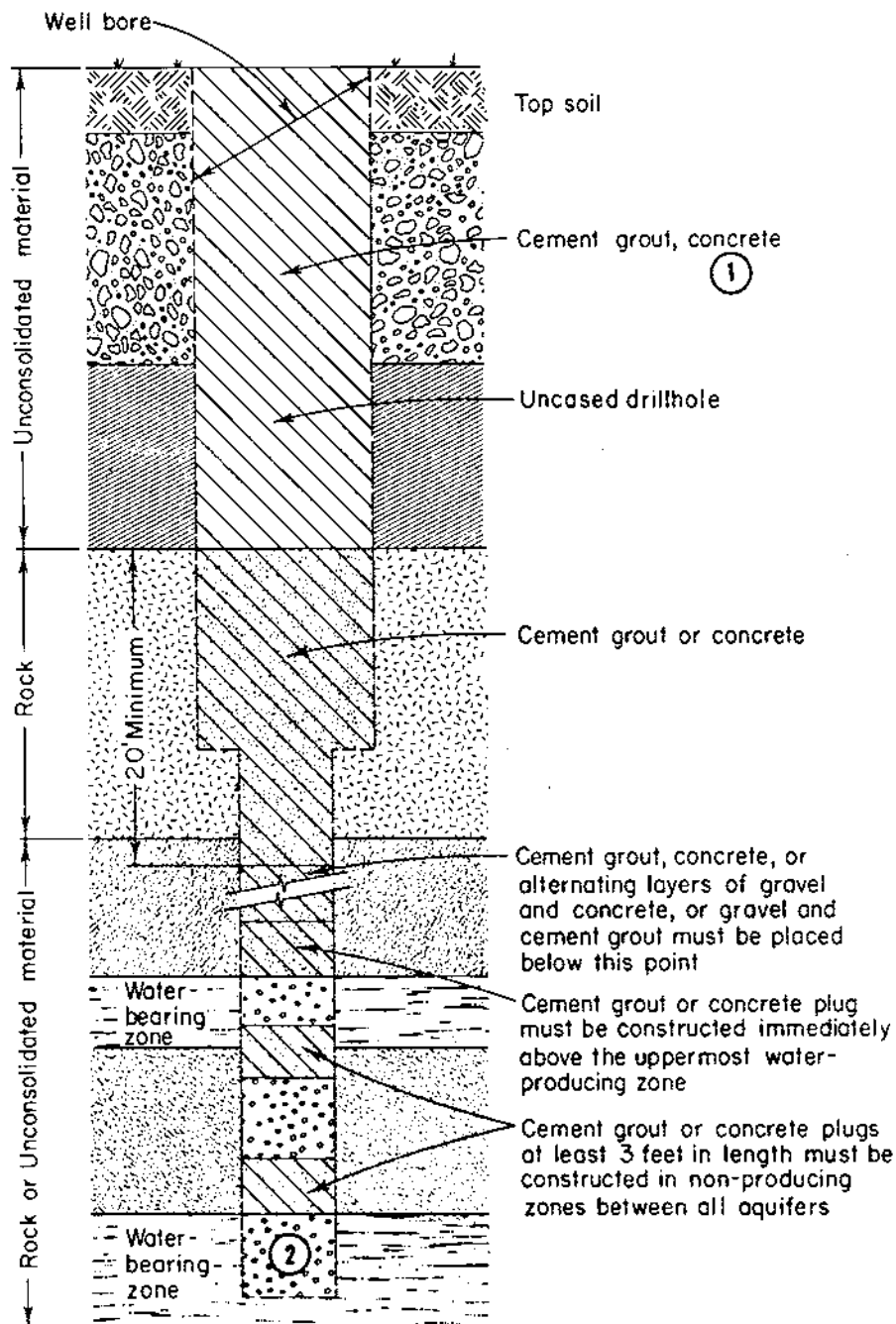

① In all wells to be abandoned, cement grout and concrete must be placed by grout pipe, tremie, or dump bailer.

② In all wells to be abandoned, sealing material must be introduced at the bottom of the well and placed progressively upward.

ABANDONMENT OF CASED WELL

(690-220-060)

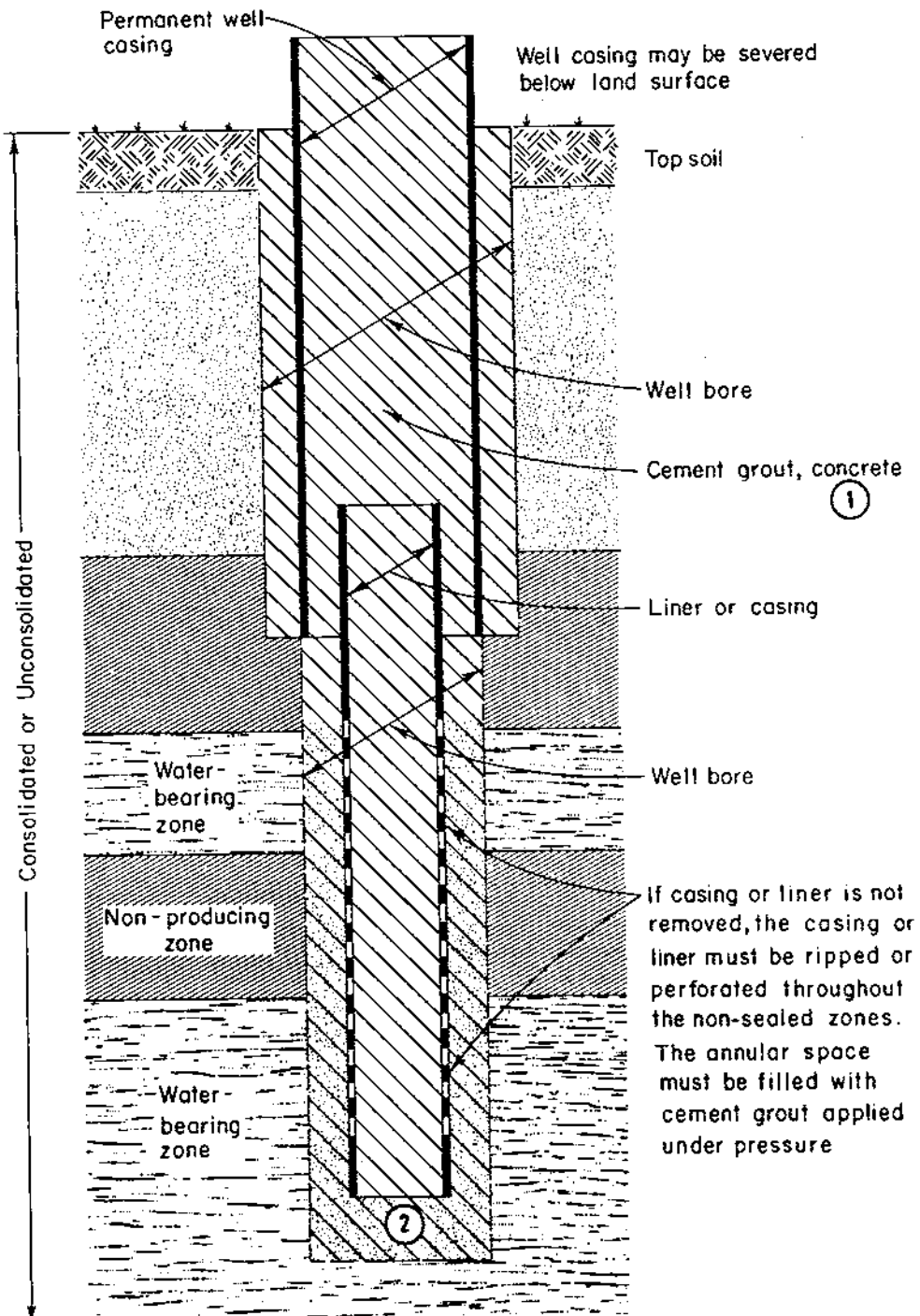

① In all wells to be abandoned, cement grout and concrete must be placed by grout pipe, tremie or dump bailer.

② In all wells to be abandoned, sealing material must be introduced at the bottom of the well and placed progressively upward.

ABANDONMENT OF ARTESIAN WELL

(690-220-070)

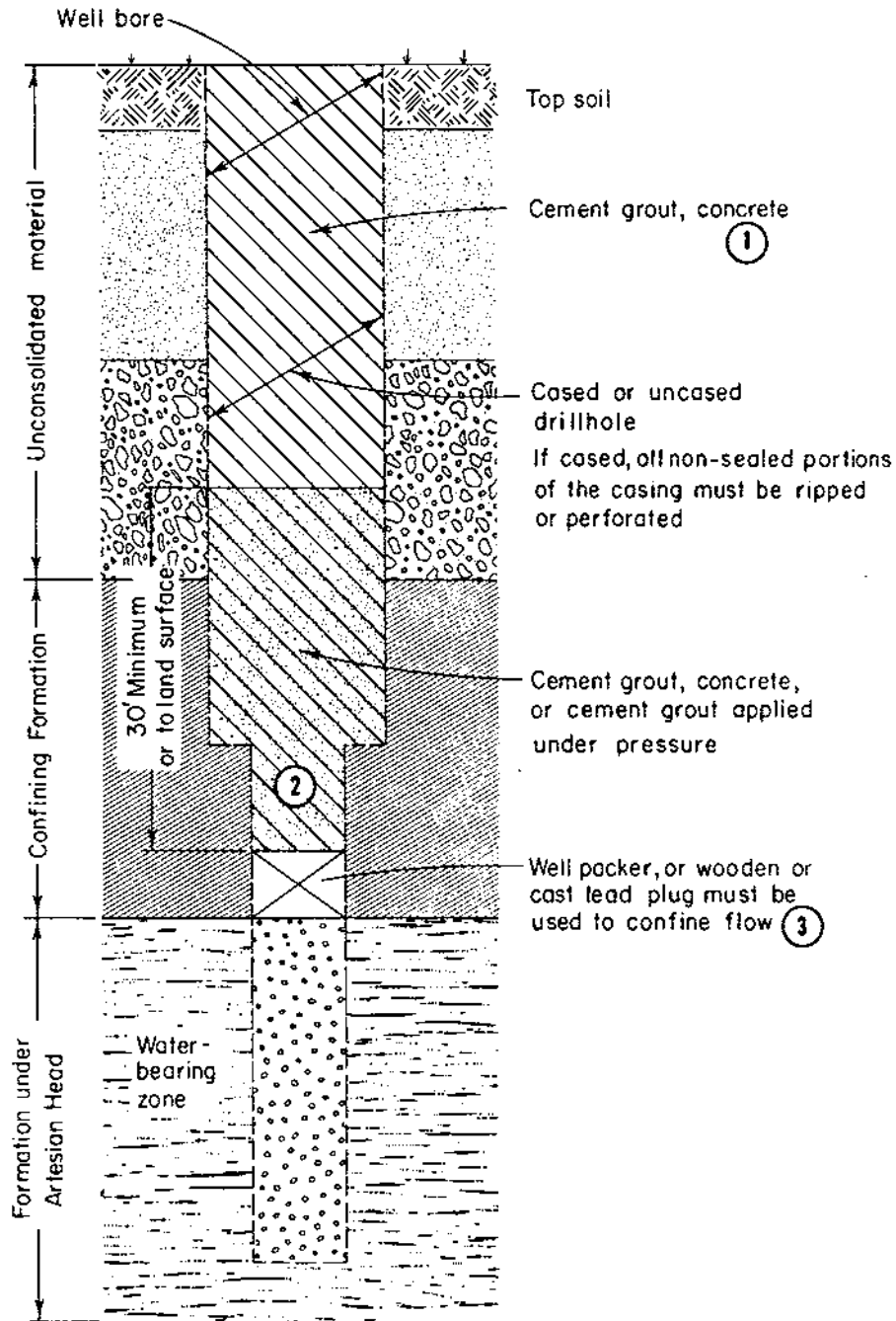

- ① In all wells to be abandoned, cement grout and concrete must be placed by grout pipe, tremie or dump bailer.
- ② In all wells to be abandoned, sealing material must be introduced at the bottom of the well and placed progressively upward.
- ③ Preshaped or precast plugs should be several times longer than the diameter of the well to prevent tilting.

SUGGESTED METHODS OF INSTALLING ACCESS PORTS, PRESSURE GAUGES, AND AIR LINES FOR MEASURING WATER LEVELS IN WELLS

(690-210-280)

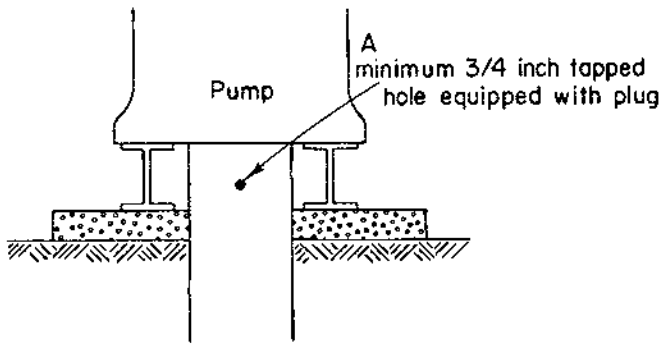

ACCESS PORT FOR MEASURING DEVICE

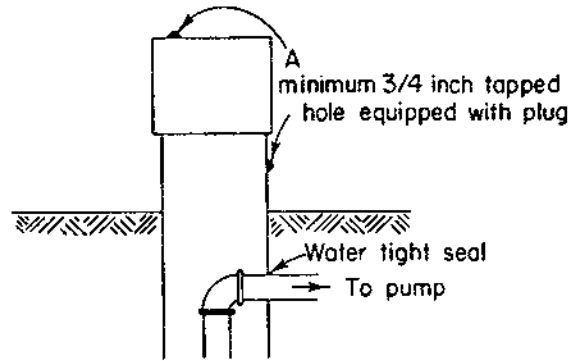

ACCESS PORT FOR MEASURING DEVICE

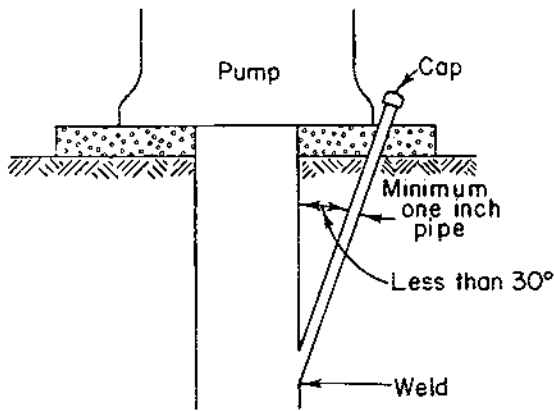

ACCESS PORT FOR MEASURING DEVICE

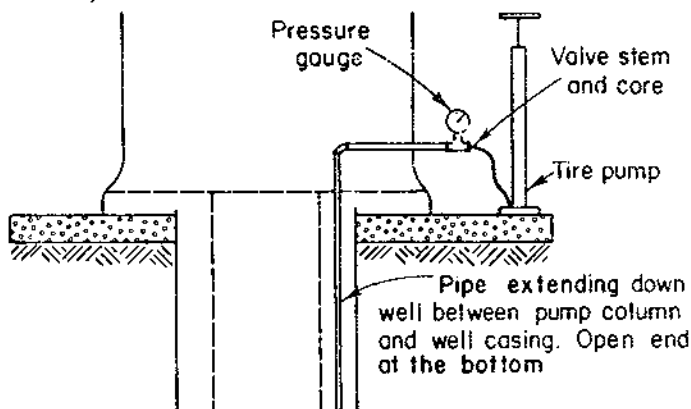

AIR LINE INSTALLATION

An air line installation is recommended where the water level lies at a considerable depth below land surface. The amount of air pressure that can be built up inside the air line will be equal to the depth of water standing above the bottom of the air line. The exact depth to the bottom of the air line is required to obtain an accurate measurement of the water level in the well. One pound per square inch pressure equals 2.31 feet of water.

EXAMPLE OF WELL STANDARDS ENFORCEMENT PROCESS

(690-225)

INCREASING SEVERITY
OF ENFORCEMENT

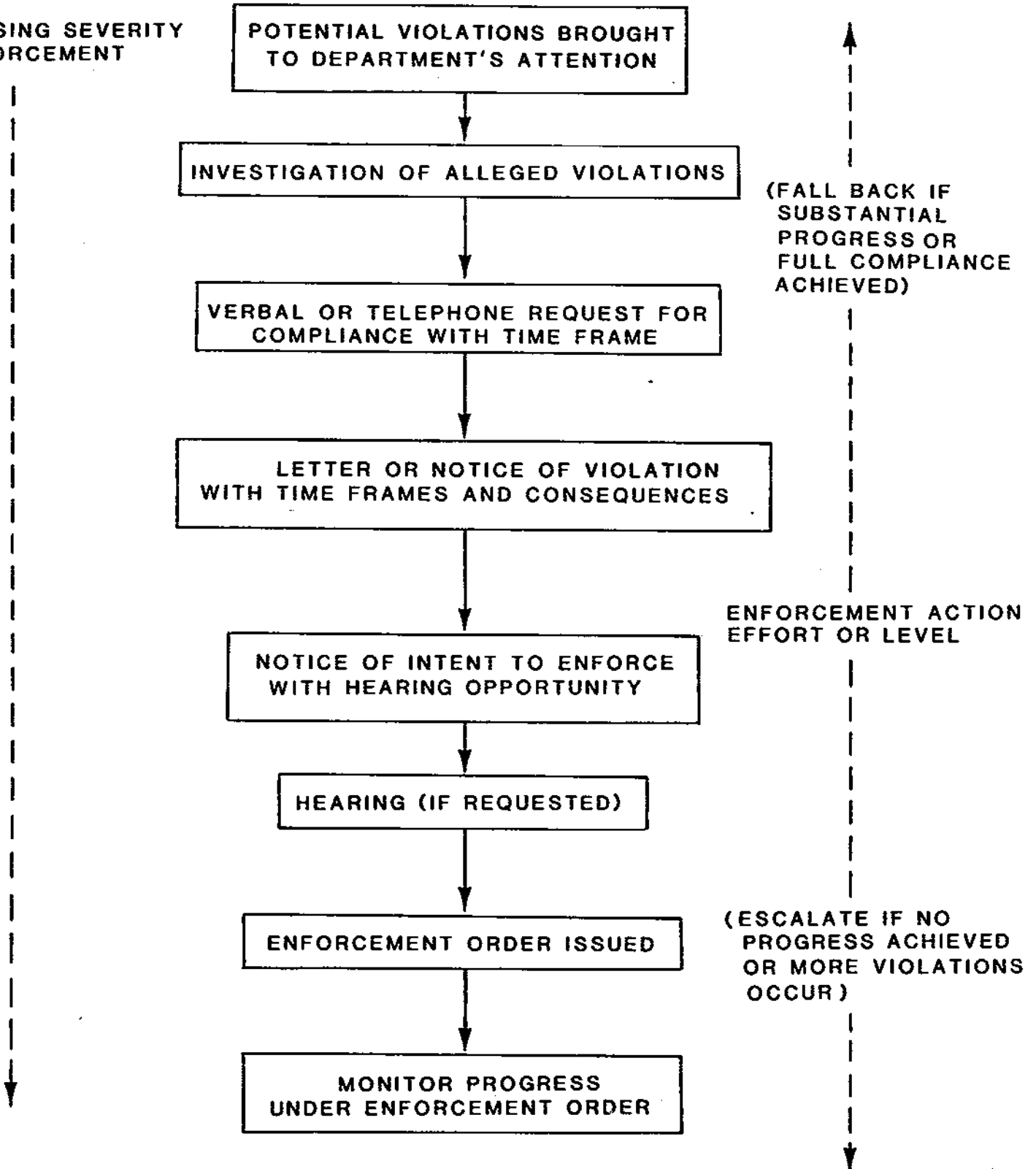



It is desirable to achieve compliance at the lowest possible level of enforcement. Escalation of enforcement can be expected if compliance does not result at the next lower level. Reduction of enforcement effort can be expected if substantial progress towards compliance is achieved.

CRITICAL GROUND WATER AREAS

690-200-027

Map Legend

-  CRITICAL GROUND WATER AREAS
-  PROPOSED CRITICAL GROUND WATER AREAS
-  GROUNDWATER WITH-DRAWAL AREA

Map Scale = 1:3841321

State Plane
Coordinate System



State of Oregon
WATER RESOURCES DEPARTMENT

June 1988

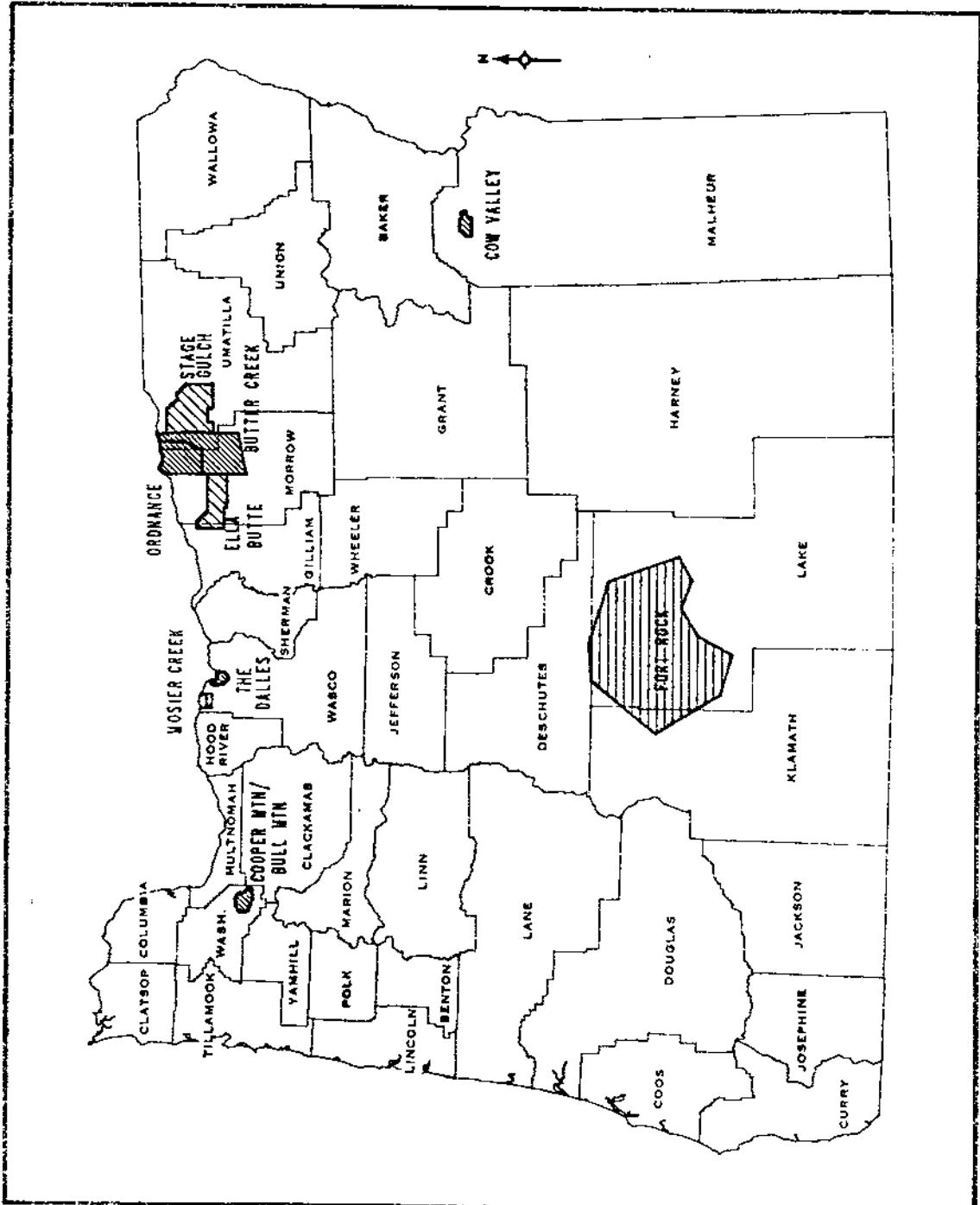

FIGURE 19